

CALIFORNIA PATH PROGRAM
INSTITUTE OF TRANSPORTATION STUDIES
UNIVERSITY OF CALIFORNIA, BERKELEY

California Intersection Decision Support: A Systems Approach to Achieve Nationally Interoperable Solutions II

Jim Misener, et al.

**California PATH Research Report
UCB-ITS-PRR-2007-1**

This work was performed as part of the California PATH Program of the University of California, in cooperation with the State of California Business, Transportation, and Housing Agency, Department of Transportation, and the United States Department of Transportation, Federal Highway Administration.

The contents of this report reflect the views of the authors who are responsible for the facts and the accuracy of the data presented herein. The contents do not necessarily reflect the official views or policies of the State of California. This report does not constitute a standard, specification, or regulation.

Final Report for Task Order 5600

January 2007

ISSN 1055-1425

Task Order 5600 Final Report
California Intersection Decision Support: A Systems Approach to
Achieve Nationally Interoperable Solutions II

Authors

James A. Misener
Ching-Yao Chan
Delphine Cody
Susan Dickey
Christopher Nowakowski
Dan Greenhouse
David Ragland
Steven E. Shladover
Joel Vanderwerf

Team Members

Tony Mak
David Marco
Khoi Nguyen
Paul Ossenbrugen
Swe-kuang Tan
Xiqin Wang
Aleksandr Zabysny
Marco Zennaro
Theodore Cohn

Table of Contents

ABSTRACT.....	XI
KEY WORDS.	XI
EXECUTIVE SUMMARY	XIII
BACKGROUND AND INTRODUCTION.....	XIX
Questions in <i>Design and Implementation</i>	xxii
1 Summary of IDS Research.....	1
1.1 SUMMARIZING THE KEY TECHNICAL LESSONS LEARNED FROM OUR IDS RESEARCH:1	
1.1.1 Traffic Signal Controllers and Cabinets.....	4
1.1.2 Sensors and Detectors.....	5
1.1.3 Threat Assessment Algorithms.....	6
1.1.4 Displays to Drivers.....	7
1.1.5 Wireless Communications.....	8
2 Intersection Decision Support Project IDS Task B1 Report: Pilot Field	
Observations Data Collection and Analysis	11
2.1 SUMMARY	11
2.2 BACKGROUND.....	14
2.3 DESCRIPTION OF TRAFFIC OBSERVATION STUDY	15
2.4 DATA DESCRIPTIONS.....	17
2.5 TRAFFIC FLOW PATTERNS VERSUS SIGNAL PHASES	18
2.5.1 Detection of Left-Turn Vehicles versus Opposing Traffic	21
2.6 SUMMARY OF TRAFFIC PATTERN OBSERVATIONS.....	23
2.7 TIME TO INTERSECTION (T2I) ANALYSIS.....	24
2.8 APPLICATION OF T2I ASSESSMENT FOR LTAP-OD SCENARIOS	28
2.9 VIDEO DATA ANALYSIS.....	30
2.10 DATA ANALYSIS & RESULTS.....	32
2.11 GAP ACCEPTANCE:.....	33
2.12 TURNING TIME, GAP ACCEPTANCE AND BUFFER	36
2.13 FURTHER EVALUATION	39
2.14 CONCLUSION.....	40
2.15 ACKNOWLEDGEMENTS.....	41
2.16 REFERENCES.....	42
3 Intersection Observation Report—Radar and Video.....	44
3.1 INTRODUCTION.....	44
3.2 RADAR OBSERVATION REPORT	46
3.2.1 Introduction.....	46
3.2.2 Motivation and Method of Approach	47
3.2.3 Field Observation—Data Collection	48
3.2.4 Interpretation of Driver Behaviors Based on Field Observation	56
3.2.4.1 <i>Characterization of Left-Turn Traffic Conditions by POV TTPOC and</i>	<i>57</i>
3.2.4.2 <i>Driver Behaviors under Different Traffic Conditions</i>	<i>61</i>
3.2.4.3 <i>Driver Behaviors at Different Intersections</i>	<i>65</i>

3.2.5	Time-Gap Acceptance Analysis for LTAP-OD Scenarios	71
3.2.5.1	<i>SV-POV Interaction</i>	72
3.3	CONCLUSION	83
4	Video Observations of LTAP-OD Maneuvers: Description of Basic Findings and Implications for IDS	85
4.1	EXECUTIVE SUMMARY	85
4.1.1	Rationale and Methods.....	85
4.1.1.1	<i>Distribution of available gaps</i>	85
4.1.1.2	<i>Gap acceptance by length of gap (Gap acceptance curve)</i>	86
4.1.1.3	<i>Turning Time by Intersection</i>	87
4.1.1.4	<i>Turning Time by Type of Turn</i>	88
4.2	INTRODUCTION.....	89
4.3	BACKGROUND.....	91
4.3.1	A Driver “Model” for Choosing a Gap and How IDS Can Help.....	92
4.3.1.1	<i>Estimated Gap</i>	95
4.3.1.2	<i>Estimated Total Turning Time</i>	97
4.4	METHODS.....	100
4.4.1	Characteristics of Intersections	100
4.4.2	Video Data Collection and Analysis	103
4.4.3	Breakdown of Observations.....	106
4.4.4	Types of Analysis.....	107
4.5	RESULTS.....	108
4.5.1	Distribution of gaps presented to the SV driver	108
4.5.1.1	<i>Basic results</i>	108
4.5.1.2	<i>Gaps presented to the SV driver as a log-normal distribution</i>	111
4.5.2	Gap acceptance curves	112
4.5.2.1	<i>Basic results</i>	112
4.5.2.2	<i>Gap acceptance curves modeled by the logistic function</i>	116
4.5.3	Turning time.....	119
4.5.3.1	<i>By intersection</i>	119
4.5.3.2	<i>Turning time within intersections</i>	121
4.5.3.3	<i>Turning time by type of turn</i>	122
4.5.3.4	<i>Turning times</i>	124
4.6	FUTURE RESEARCH	125
5	DII Laboratory Experiments Final Report	127
5.1	BACKGROUND.....	127
5.2	PHYSICAL PROPERTIES	133
5.3	REACTION TIME EXPERIMENTS	135
5.4	RESULTS	139
6	Summary of Driver Behavior Studies	145
6.1	HOW DO DRIVERS APPROACH LEFT-TURN INTERSECTIONS?	145
6.2	HOW LONG DOES IT TAKE DRIVERS TO TRAVERSE AN INTERSECTION?	146
6.3	WHAT “GAPS” IN THE ONCOMING TRAFFIC ARE TYPICALLY ACCEPTED OR REJECTED?.....	147

6.4 WHEN ARE DECISIONS BEING MADE BY THE SV DRIVER?	149
6.5 HOW CAN A CONFLICT BETWEEN THE TURNING SV AND POV BE ACCURATELY PREDICTED?	150
7 DATA FUSION FOR VEHICLE DETECTION: USING RADAR AND LOOPS FOR INTERSECTION DECISION SUPPORT (IDS)	153
7.1 INTRODUCTION	153
7.2 HARDWARE SETUP AND DATA COLLECTION	154
7.2.1 Overall System Structure	154
7.2.2 Radar and Micro-Loop Setup	155
7.2.3 Vehicle Ground Truth and Data Collection	155
7.3 SENSOR DETECTION, FILTERING AND FUSION	156
7.3.1 Radar Data Filtering for Target Detection	156
7.3.1.1 <i>Radar Target Tracking and Filtering</i>	157
7.3.1.2 <i>Discussion for Test Data</i>	161
7.3.2 Micro-loop Detection	161
7.3.2.1 <i>Information Retrieval from Micro-loops: Detection Start Time</i>	161
7.3.2.2 <i>Information Retrieval from Micro-loops: Presence Signal</i>	162
7.3.2.3 <i>Loop Filtering and Estimation</i>	163
7.3.3 Fusion of Micro-Loop Data and Radar Data	166
7.3.4 Fusion of Radar and Radio Data	168
7.4 CONCLUDING REMARKS	169
7.5 REFERENCES	170
8 COTS and Emerging Technologies: Sensor Testing and Evaluation	171
8.1 INTRODUCTION	171
8.2 MEASURES OF EFFECTIVENESS (MOES)	172
8.2.1 Background and General Guidelines	172
8.2.2 Hypotheses and Assumptions	173
8.2.3 Constraints and Limitations	173
8.2.4 Evaluation Criteria	174
8.2.4.1 <i>Discrete Sensors</i>	174
8.2.4.2 <i>Continuous Sensor</i>	175
8.2.4.3 <i>Vehicle-Based Sensors</i>	177
8.3 SURVEY SOURCES	177
8.4 REVIEWED PRODUCTS	178
8.5 EXPERIMENTAL FACILITY – INTELLIGENT INTERSECTION AT RICHMOND FIELD STATION (RFS)	180
8.6 EXPERIMENTAL EVALUATION OF SELECTED PRODUCTS	185
8.6.1 3M Canoga Microloops	185
<i>Product Description and Standard Use</i>	185
<i>Experimental Results</i>	186
Test No. 1	186
Test No. 2.....	189
8.6.2 VDS240 (Sensys)	192
<i>Product Description and Standard Use</i>	192
Experimental Results	193

8.7 TRAFICON VIDEO DETECTION SYSTEM.....	195
Product Description and Standard Use	195
<i>Experimental Results</i>	197
Test No. 1	198
Test No. 2.....	199
Test No. 3.....	201
8.8 RTMS (EIS)	205
Product Description and Standard Use	205
Experimental Results.....	207
8.9 STANDARD IN-PAVEMENT LOOPS.....	208
Product Description and Standard Use	208
Experimental Results.....	209
8.10 SUMMARY AND RECOMMENDATIONS	213
8.11 ACKNOWLEDGMENTS	215
9 Design of Alert Criteria for an Intersection Decision Support (IDS) System	217
9.1 IDS ALERT SYSTEM DESIGN CONSIDERATIONS.....	217
9.1.1 “Decision Support” Rather than “Warning”	217
9.1.2 Suitability for Entire Driving Population	217
9.1.3 Need for Consistency with Current Gap Acceptance.....	218
9.1.4 Safety Considerations to Govern Minimum Acceptable Gaps	218
9.1.5 Alert Criteria Considering Both Gap Size and When to Alert.....	219
9.1.6 Subjectivity of Alert Criteria	220
9.1.7 Determining When to Extinguish IDS Alert	221
9.1.8 10.1.8. Long-Term Compatibility with Driver Behavior.....	221
9.1.9 Influence of Traffic Signal Phase.....	222
9.1.10 Need to Predict Future Vehicle Trajectories and Turning Movements.....	223
9.1.11 Influence of Intersection Geometry, Traffic and Weather Conditions.....	224
9.1.12 Accommodating Limitations of Real Sensor Data.....	224
9.2 DESIGN OF IDS LTAP/OD ALERT	225
9.2.1 LTAP/OD Alert Logic	226
9.2.2 Calibration of Parameter Values.....	230
9.3 SIMULATIONS TO EVALUATE LTAP/OD ALERTS.....	231
9.3.1 Models	232
9.3.2 Sensors	232
9.3.3 Driver and Vehicle	233
9.3.4 Simulation Experiments	233
9.4 SENSITIVITY TO INSUFFICIENT INFORMATION ABOUT VEHICLE MOTIONS	238
9.5 CONCLUSIONS.....	246
9.6 REFERENCES.....	246
10. Tool 1: Sensor and warning system evaluation in specific intersection geometries without driver model	249
10.1 OVERVIEW	249
10.2 SOFTWARE REQUIREMENTS.....	250
10.3 MODEL SOFTWARE ARCHITECTURE	251
10.4 MODEL REQUIREMENTS.....	254

10.5 SENSORS	255
10.6 DRIVER AND VEHICLE	256
10.7 ROAD GEOMETRY	256
10.8 MODEL REPORT	257
10.9 COORDINATE SYSTEMS	257
10.10 SOFTWARE MANUAL	258
11. Task 1 Report: Collection and Documentation of Functional Requirements and Performance Specifications	271
11.1 BACKGROUND AND DEFINITION OF CICAS GOALS	272
11.2 HYPOTHESES ABOUT CRASH CAUSALITY	276
11.3 A CONCEPT OF OPERATIONS FOR CICAS	281
11.4 SYSTEM-LEVEL FUNCTIONAL REQUIREMENTS	287
11.4.1 CICAS Alert Generation Requirements to Support Overall Goals ..	289
11.4.2 Requirements for Detection and Sensing Derived from Section 4.1 .	291
11.4.3 Requirements for Driver Interfaces (DII, DVI) Derived from 4.1	292
11.4.4 Requirements for Information Processing Derived from 4.1	293
11.4.5 Requirements for Data Interfaces (to traffic signal controllers, wireless to/from vehicles) Derived from 4.1	293
11.4.6 Cross-Cutting Requirements Derived from 4.1 and Costs, Based on Compatibility with CICAS Goals	294
Glossary	295
APPENDIX A. RADAR CONFIGURATION AND COORDINATE TRANSFORMATION	301
A.1. Radar Specifications	301
A2. Coordinate System Transformation	301
Appendix B. Distribution of types of SV left turns observed	303
APPENDICE C: SPECIFICATIONS OF TESTED PRODUCTS	305
3M Canoga Microloops	305
<i>Sensys VDS240 Specifications</i>	<i>305</i>
<i>Sensys VDS240 Timing Scheme</i>	<i>305</i>
TRAFICON VIDEO DETECTION SPECIFICATIONS	307

List of Figures

- Figure 0.1 Schematic of PATH IDS Demo
- Figure 0.2 LTAP/OD Scenario. Blue Arrow Represents Subject Vehicle, and Red Arrow Represent Principal Other Vehicle
- Figure 3.10 POV-TTPOC Distribution vs. Time Relative to SV Crossing POC (Data 10/02/03)
- Figure 3.21 POV-DTPOC Distribution vs. Time Relative to SV Crossing POC (Site D)
- Figure 4.1 Model of SV Driver Process for Choosing a Gap
- Figure 4.2 Video Data Collection Fields
- Figure 4.3 Screen shot of video data analysis tool of view
- Figure 4.4 Arrow indicating the gap between two consecutive POVs
- Figure 4.5 Arrows indicating points in the turning path of the SV at an intersection

Figure 4.6 Distribution gaps of 12 seconds or less for all intersections combined (n=833).

Figure 4.7 Distribution gaps of 12 seconds or less for individual intersections (n=833).

Figure 4.8 Log-normal function fitted to distribution of gaps presented to the SV driver, for all intersections combined

Figure 4.9 Percent of gaps accepted by gap length.

Figure 4.10 Logistic function describing the gap acceptance for all four intersections in the analysis. Arrow is Accept50 for curve representing the four intersections combined.

Figure 4.11 Actual vs. logistic function gap acceptance curve

Figure 4.12 Distribution of Turning Time by Intersection

Figure 5.1 R3-2

Figure 5.2 Richmond Field Station Testing Intersection

Figure 5.3 DII Unit

Figure 5.4 Second Generation DII Units

Figure 5.5 (above) Luminance DII Unit

Figure 5.6 Individual LEDs

Figure 5.7 Custom Color Bands. Note that white areas in the image represent luminance that is higher than the ranges shown in the color key, thus greater than 15000 cd/sqm.

Figure 5.8 Electronic Control System of Computer

Figure 5.9 Outline of Theory Operation

Figure 5.10 Experiment of DII viewing

Figure 7.0.1 (a): Scenarios for LTAP/OD and LTAP/LD; (b) Overall system structure for Test Intersection Detection Systems, Loops are accessed from PC/104 bypassing the 2070 Controller

Figure 7.0.2 Radar setup and field of view with respect to the micro-loops

Figure 7.0.3 Radar filtering, tracking, and prediction

Figure 7.0.4 Start-time sequence versus loop sequence in vehicle moving direction: (a) Normal case; (b) Abnormal case – loops encountered later detected the vehicle earlier; vehicle speed: 30[mph]

Figure 7.0.5 Typical presence signal, properly scaled

Figure 7.0.6 Speed estimation for two runs to show the effect of vehicle speed: blue = vehicle speed; cyan = average; magenta = moving average

Figure 7.0.7 Kalman filter estimated D2I (line) versus micro-loop D2I (dots)

Figure 7.0.8 Kalman filter estimated speed (dots) versus wheel speed (line)

Figure 7.0.9 Fusion of loop and radar estimates. Upper: 3 consecutive runs; Lower: Zoomed 3rd speed peak. Colors: red = radar, green = moving average loop estimate, blue = fusion of two with larger weight on radar.

Figure 7.0.10 (1) Vehicle speed (Top) – estimated from micro-loops (green); measured by radar (red); and fusion of the two with the vehicle speed passed over by communication (blue); (2) D2I (Middle), the same fusion scenario as speed; (3) acceleration estimated (Lower);

Figure 8.1 RFS Intelligent Intersection

Figure 8.2 Diagram of Sensors at RFS Intelligent Intersection

Figure 8.3 Diagram of Loops, Microloops and Radars at RFS Intelligent Intersection

Figure 8.4 PATH RFS Intelligent Intersection with 3M Canoga Microloops

Figure 8.5 3M Canoga Microloops Graphical Data of Constant Speed

Figure 8.6 3M Canoga Microloops Graphical Data of Variable Speed

Figure 8.7 3M Canoga Microloops - Frequency of Positive and Negative Residuals
 Figure 8.8 Sensys VDS240 Sensors on PATH Testbed
 Figure 8.9 Sensys VDS240 Node and Internal Speed Percentage Error
 Figure 8.10 Traficon Video Camera at PATH RFS Intelligent Intersection
 Figure 8.11 Sketch of Traficon Data Detection Zones
 Figure 8.12 PATH Testbed with Standing Water
 Figure 8.13 Traficon False Detections, Test #1
 Figure 8.14 Traficon Detections per Run, Test #2
 Figure 8.15 An Example of Traficon Detections per Run per Zone, Test #2
 Figure 8.16 PATH Testbed under Clear Skies
 Figure 8.17 Traficon Speed Detection in Zone 1, Test #3
 Figure 8.18 Traficon Speed Detection in Zone 2, Test #3
 Figure 8.19 Traficon Speed Detection in Zone 3, Test #3
 Figure 8.20 Traficon Speed Detection in Zone 4, Test #3
 Figure 8.21 Absolute Percent Error between Traficon and Car Wheel Speed
 Figure 8.22 Road Traffic Microwave Sensor by Electronic Integrated Systems
 Figure 8.23 Sketch of RTMS Detection Zone at IDS Intelligent Intersection
 Figure 8.24 Diagram of Standard In-Pavement Loops in PATH Testbed
 Figure 8.25 Standard In-Pavement Loops Cumulative Data Represented Graphically
 Figure 8.26 Standard In-Pavement Loops Resulting Average Data
 Figure 8.27 Standard In-Pavement Loops Data Represented Graphically
 Figure 9.0.1 *LTAP/OD Alert System Design Criteria*
 Figure 9.0.2 *Logical Flow of LTAP/OD Alert*
 Figure 9.0.3 *Definitions of Variables Used for Alert Criteria*
 Figure 9.0.4 *Kinematics of Encounter Between POV Accelerating to Beat Red Signal and SV Decelerating to Turn Left*
 Figure 9.0.5 Sensor Detection of Vehicle Trajectories and Their Use to Trigger Successful IDS Alert
 Figure 9.0.6 Sensor Detection of Vehicle Trajectories Insufficient to Trigger Timely IDS Alert
 Figure 9.0.7 LTAP/OD Alert Challenges with SV Decelerating at 0.2 g
 Figure 9.0.8 LTAP/OD False Alarm Challenges with POV Decelerating at 0.07 g
 Figure 9.0.9 Example of False Positive for POV Approaching at 20 mph, but Assumed at 28 mph Default Speed
 Figure 9.0.10 Example of False Negative for POV Approaching at 30 mph, but Assumed at 28 mph Default Speed
 Figure 11.1 Intersection Crossing Path Crash Types
 Figure 11.2 Definition of Terms in LTAP/OD Conflict

List of Tables

Table 2-0-1 Turning Time Under Different Situations
 Table 2-0-2 Gaps accepted under different situations
 Table 3-1 Intersection and Traffic Characteristics of Field Observation Sites
 Table 3-2 Observed Turning Times of SVs under Various Conditions

Table 4-1 Intersection and Traffic Characteristics of Field Observations Sites
Table 4-2 Police reported collisions at five intersections from 1999 to 2003 by type of collisions (LTAP-OD, other crossing path, and other)
Table 4-3 Gap lengths observed (accepted and rejected) at five intersections (N=1573)
Table 4-4 Percentage of gaps 12 seconds or below
Table 4-5 Statistics for gap acceptance curves by intersection and for all intersections combined
Table 4-6 SV turning time by intersection (n=905)*
Table 4-7 Types of left turns in five intersections
Table 4-8 SV turning times by type of left turn
Table 5-1 Results I
Table 5-2 Results II
Table 5-3 Results III
Table 8-1 Summary of Tested Devices
Table 11-1 Alternative combinations of capabilities of intersection broadcasts of dynamic state map data
Table 11-2 Addressing signal violation and turning conflict alerts with varying levels of infrastructure equipment

Abstract

The overall IDS research plan was constructed to realize, in slightly more than three years, the requirements, tradeoffs assessment, and technology investigations necessary to define an IDS. Toward the end of the project we will combine our understanding of the problem definition, IDS technologies and our integration experience with a standard Caltrans intersection (with advanced controller) and design a deployable IDS demonstration that can be field-tested.

With the availability of sensing, communication, and computing technologies, IDS systems are promising for the reduction of crashes, fatalities, and injuries on the roadway. Currently, Federal and State governments are partnering with private industries and academia institutions to pursue the deployment of intersection decision support (IDS) and cooperative intersection collision avoidance systems (CICAS), which seek to combine infrastructure-based and vehicle-based functions to provide optimal solutions for roadway users.

Key Words.

Intersection safety, LTAP/OD, cooperative systems, active safety, crossing path crashes, Infrastructure Consortium

Executive Summary

The Intersection Decision Support (IDS) project addresses the application of infrastructure-based and infrastructure-vehicle cooperative systems to address intersection safety. The Infrastructure Consortium (IC) comprises the US Department of Transportation (DOT), California DOT (Caltrans), Minnesota DOT, and Virginia DOT.

In defining this “best” IDS, we recognize that several potential dimensions are important. These dimensions include: (i) multiple views on the size of problem (be it by crash frequency, severity or fatality); (ii) grouping of cognitive or engineering causal factors, (iii) solution approaches can be addressed by certain technologies, and finally (iv) what can be cost-effectively deployed, in the near-term and also in the far-term. Our overall work plan addresses these tradeoffs, and in the end, we will arrive at a definition of a nationally interoperable IDS solution and an appropriate FOT.

To satisfy these dimensions, the project's mission is to investigate key enabling technologies, conduct naturalistic driving data collection, perform driver modeling, develop an integrated IDS simulation approach, and look at the applicability of a large set of already- or nearly-available “commercial off the shelf” systems toward meeting IDS requirements. We also investigate the use and usability of roadside-mounted dynamic message signs.

The effort reported here specifically addresses the common crash scenario in which a driver makes a left turn across the path of a vehicle approaching from the opposite direction (i.e., “Left Turn Across Path/ Opposing Direction” or LTAP/OD crash scenario). LTAP/OD crashes account for 27.3 % of all US intersection-related crashes, according to National Accident Sampling System (2000) and Smith and Najim (2002), and two-thirds of all LTAP/OD crashes occur at signalized intersections. Before designing an IDS infrastructure system, the reasons for such crashes were considered including:

- driver failure to judge safe time gaps correctly,

- driver failure to judge the speeds of closing vehicles,
- driver failure to see the oncoming vehicle (i.e., “looked but did not see”), and
- obstruction of the driver’s view by an opposing vehicle.

As an up-front exercise, we examined the GES and other data sources further to develop a taxonomy of crossing path crashes and to develop a profile of pre-crash scenarios and causal factors that contribute to such crashes, preparing the groundwork for engineering approaches in preventing crossing path collisions. The current study builds on and extends prior work by using data from the year 2000 GES to provide a profile and discussion of:

- crossing path crashes by junction type (i.e., non junction, intersection junction, or non-intersection junction);
- crossing path and other crashes at intersections by vehicle-level traffic-control configuration;
- crossing path and other crashes by speed limit;
- crossing path and other crashes by age and gender.

Findings and, in bold, implications for IDS:

1. *Junctions are High-Risk Sites for Crashes*

Crashes at junctions overall (defined as the connection of two roadways) represent about 60 percent of U.S. crashes, and most of these (or about 44% of all crashes) occur at intersections (a specific type of junction). Because junctions (and intersections in particular) represent a very small proportion of all streets and highways, they carry a much higher risk for crashes than other types of street or highway segments. Therefore, safety enhancements at such sites would be an efficient investment. Specifically, **IDS countermeasures designed to prevent crashes at junctions in general, and intersections in particular, could efficiently address a significant share of all traffic crashes.**

2. *Crossing Path Crashes are a Significant Problem*

Crossing path crashes represent 25 percent of all U.S. crashes¹. Types of crossing path crashes include:

- straight crossing path crashes (SCP) (8.6 percent);
- left-turn across path, opposite direction crashes (LTAP-OD) (6.7 percent);
- left turn across path, lateral direction crashes (LTAP-LD) (4.8 percent);
- right turn into path crashes (RTIP) (1.5 percent);
- left turn into path crashes (LTIP) (1.5 percent);
- other types of crossing path crashes (2.0 percent).

While each type of crash represents different pre-crash vehicle movements and a different mix of causal factors, **each type could be reduced by using IDS countermeasures to support driver decisions at intersections and other junctions.**

3. *Most Intersection Crashes Occur at Controlled Intersections*

We found that among intersection crashes, most (74 percent) occurred at intersections with some type of traffic control device in place including 46 percent at signalized intersections, 16 percent at two-way stop-sign intersections, 6 percent at four-way stop sign intersections, 5 percent at intersections with some other type of control.

IDS approaches should coordinate with existing traffic control devices.

4. *Many Crashes Occur at Uncontrolled Intersections*

About one quarter (26 per cent) of intersection crashes occur at intersections with no physical traffic control devices. While statutory controls may apply at these intersections, the GES codes them as “uncontrolled”. **If uncontrolled intersections have such light traffic that they don’t even warrant a physical control device, there would probably be no justification for an IDS infrastructure installation, and it may be that collisions at intersections with no traffic control devices are best addressed by vehicle-based systems.**

5. *Types of Crashes at Intersections Vary by Type of Traffic Control*

Crash types at intersections differ substantially by type of traffic control configuration.

- The majority of crashes at signalized intersections are LTAP-OD, SCP, and rear-end crashes (73 percent).

- The majority at two-way stop intersections are SCP and LTAP-LD (71 percent).
- The majority at four-way stop intersections are SCP and rear-end crashes (59 percent).

The differences represent the impact of traffic control on vehicle flow and reflect varying pre-crash vehicle movements. **IDS approaches will need to address the different patterns of crash types occurring with different traffic control configurations.**

6. *Driver Errors are Primary Causal Factors in Intersection Crashes*

Based on police reports, driver failure is the most frequently identified causal factor in crashes including failure to see crucial information (e.g., obstruction of view, driver distraction); and failure to correctly judge available information (e.g., misjudged speed of or distance to another vehicle). **IDS is designed to address both of these cases by increasing the salience and relevance of information available to drivers about potential risks as they navigate the intersection.**

7. *Most Crashes Occur at Moderate Speeds*

A substantial proportion of intersection crashes takes place at intersections where speed limits are relatively moderate:

- Almost 72 percent of crashes occur in intersections with speed limits of 40 miles per hour or less.
- An additional 21 percent occur at intersections with speed limits between 45 and 50 miles per hour.
- Only seven percent take place where the speed limit is 55 miles per hour or greater.

Even assuming that the average vehicle speed is higher than the posted speed, most intersection crashes are likely taking place at moderate speeds. **This has implications for IDS algorithms for detection of conflicts and for providing information to drivers since vehicle speed is a predominant variable in these algorithms.**

8. *Older Drivers are Somewhat Over-Represented in Crossing Path Crashes at Intersections*

Most drivers in all crashes were under age 65. However, drivers age 65 and older represented 11 percent crossing path crashes compared to 6.4 percent of non-crossing path crashes. There were virtually no gender differences by type of crash. **These results suggest that IDS measures should be designed with potential functional limitations of older drivers in mind.**

9. *Many non Crossing Path Crashes Occur at Intersections*

Rear end crashes make up about 32 percent of crashes at intersections, and crashes involving pedestrians and bikes about 3 percent. While the IDS project only addresses crossing path crashes directly, **it is important to note the possible impacts of IDS measures on other types of crashes.**

10. *IDS May Reduce Risk Without Reducing Intersection Capacity*

Traditional engineering countermeasures currently address crossing path crashes and other crashes at intersections. However, these countermeasures may reduce intersection capacity, for example, by adding left-turn (substituting left lanes for through lanes) or increasing effective lost time per signal cycle, they may have other adverse affects, or they may fail to adequately meet informational needs of drivers. **IDS countermeasures may be able to reduce risk for crossing path crashes at intersections by providing salient and relevant information to drivers while maintaining intersection capacity.**

To culminate this effort, we developed and performed a demonstration at the FHWA Turner Fairbank Highway Research Center that shows how IDS may help drivers judge when they should not make a left turn in the face of an oncoming vehicle from the opposite direction (addressing the LTAP/OD problem). An important aspect of the demonstrated system was a dynamic “left turn prohibited” sign, designed with elements “looming” in order to enhance its conspicuity. This sign is activated by an approach timing algorithm using data about

approaching vehicles obtained from several commercially-available sensors. We are used an IEEE 802.11a wireless LAN communication link – designed to be similar to the emerging second-generation Dedicated Short Range Communications (DSRC) standard – to show how complete knowledge of the intersection condition derived from the infrastructure-based sensors could be communicated in real time to approaching vehicles, where it could be used to trigger in-vehicle warnings or displays.

As illustrated in Fig 0.1, the demo sequence was: Subject vehicle (SV) approaches the intersection from the North. It has a (permissive) green signal, but no left turn protection, so the driver slows down to a stop to check if it is safe to make a left turn onto the Eastbound leg of the intersection. The SV driver’s view of approaching traffic from the South is blocked by another vehicle, so that the driver cannot easily judge the speed or location of this approaching traffic, making it hard to decide whether or not to turn. While the SV driver is trying to determine whether the left turn is safe, other vehicles (“Principal Other Vehicles” – POV) are approaching the intersection from the South.

In order to help the SV driver prevent a collision or near collision, the PATH IDS system issues a warning to the SV driver by illuminating the dynamic “no left turn” sign. This sign’s signal has a pulsing effect, which uses motion to speed the human perception of the warning signal. Also, there was a laptop computer display of the real-time motions of all the vehicles near the intersection, which was wirelessly transmitted from the roadside IDS to the car, illustrating how the complete “state map” information about the intersection could be made available to an in-vehicle display or warning system.

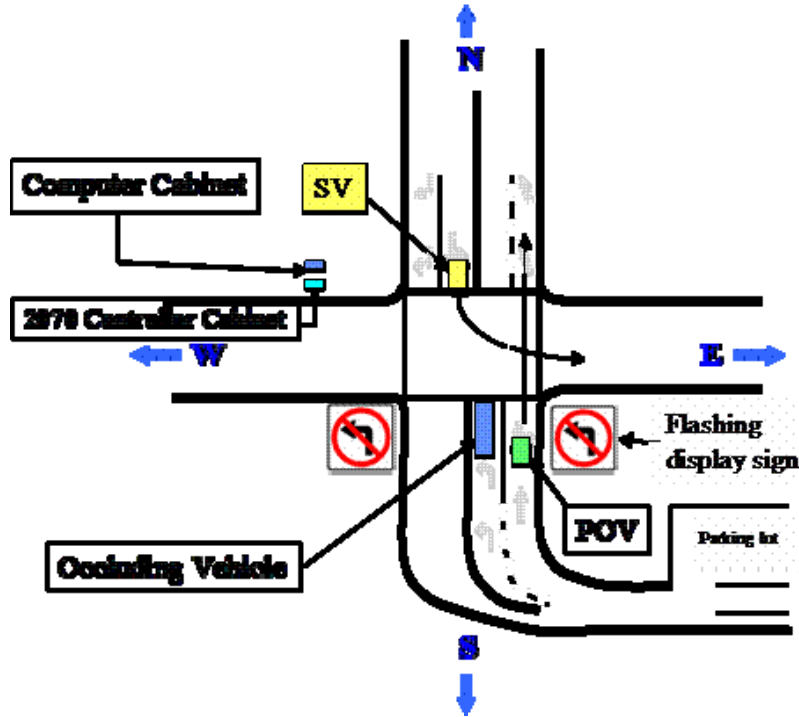

Figure 0.1 Schematic of PATH IDS Demo

These efforts lead to a follow-on Task Order (and RTA) that culminates in engineering, testing and designing for a set of end-of-program demonstrations, probably in early 2005, and thereafter one or more approaches may be selected for Field Operational Test (FOT). An FOT will be a real application on a real site.

Background and Introduction

The Intersection Decision Support (IDS) project is a product of the Infrastructure Consortium (IC), as part of a three-State DOT “Specialty Vehicle Consortium” – Caltrans (lead), Minnesota DOT, and Virginia DOT – June 1999 positive response to a request by the US DOTs ITS Joint Program Office to transform the focus from snow removal (and some emergency vehicle operation) to the more general class of vehicle-highway cooperative systems.

At the heart of the IC effort was an initial exercise to pose the following ten fundamental IDS research questions in advance, from which the IC derived requirements which drove the overall program plan. In the end, the IC will have answered these questions and defined a set of deployable IDS solutions.

Questions in *Intersection Science*

- What does the existing data tell us about what we should focus on?
- At what types of intersections are improvements possible?
- What are the requirements needed to prevent crashes at intersections?
- How do we reliably analyze the crash configurations data?
- How do we use this data to help us understand the causal relationships and design countermeasures that have a high potential for success?
- Which crash configurations are most likely to be tractable within the time period of the project?
- To what extent do rural, urban and suburban share characteristics and to what extent should they be considered separately?
- What can be learned from epidemiological studies that are relevant to countermeasure design?

Questions in *Surveillance Technology*

- How do we know where the vehicles (and the drivers) are as they approach the intersection?
- How do we design sensors to give us adequate coverage?
- How accurately can we do that?
- How do we fuse information from multiple sensors to increase our level of confidence in the information?
- What is our level of confidence in the data?
- Are sensors vehicle based or infrastructure based? Or both?
- How well do they work under a variety of outdoor environments?

- Can sensors provide data soon enough to be able to use their information for countermeasure implementation?
- How far must sensors be located from the intersection?
- If sensors are vehicle based, what data is needed and how is it used?
- Can the sensors track high-speed vehicles on rural roads?
- Or deal with the vehicles and pedestrians in densely populated urban settings?

Questions in *Human Factors*

We cannot build or design a system for preventing crashes until we understand how humans react to intersection situations and what humans (and their vehicles) can and will do under these circumstances.

- How do we turn the sensor-provided data into useful information that drivers can use?
- What do drivers do at intersections that lead to crashes?
- What are the causes of driver error?
- How do drivers make decisions at intersections?
- How does situation awareness affect their behavior?
- How soon do we need to warn them so that they can react in sufficient time to prevent crashes?
- How do we communicate with the driver?
- How can we achieve an intuitive driver response, without special training?
- How do we best assist the driver to make the right decisions?
- What should be the nature of the driver interface?
- What should be the content of the information provided to the driver?
- How should that content be delivered to the driver?
- How do we deal with learned inattention?

Questions in *Wireless Communication*

Wireless communications is more than just information passing from vehicle-to-vehicle, or vehicle-to-infrastructure. It must incorporate the ability of widely dispersed intersections to

pass information among each other (or even with central management facilities). Sensors may be dispersed along the approaches to an intersection; so sensor-to-intersection controllers or servers must be allowed.

- How will communications protocols facilitate such varying needs?
- How do we ensure that safety-critical communications take place robustly, especially with large numbers of vehicles entering and leaving the vicinity of the intersection?

Questions in *System Architecture*

- What are the necessary components of intersection decision support systems?
- How do they tie together?
- What data must pass between the subsystems?
- What are the interfaces between the subsystems?
- How do the infrastructure, the vehicles within the vicinity of the intersection and their drivers all interconnect to the driver decision-making support system?
- Can this be described explicitly so that traffic engineers and vehicle manufacturers can plan their future systems accordingly?
- Is there one architecture that can capture all the needs of an intersection decision support system?

Questions in *Design and Implementation*

Countermeasures need to take into account our best understanding of how driver error, distraction, poor judgment and other human foibles act to contribute to intersection related crashes.

- Can these countermeasures be designed and built to reliably function in a variety of different environments?
- What portion of the countermeasure is infrastructure based and what portion is vehicle based?
- How can these cooperate?
- Can intersection collision countermeasures function on vehicles only (the autonomous model)?

- How reliable are these countermeasures for a variety of different scenarios?
- How do we design countermeasures that do not impede the traffic flow?

Questions in *Evaluation and Validation*

- How the countermeasures are best evaluated in environments that do not perfectly match the real world?
- What validation procedures will be used to ensure that the evaluation experiments replicate real world conditions?
- Can experiments be designed that allow for sharing of results across different intersection scenarios?
- What do we want to learn from each of the experiments?

Questions on *Development of Driver Behavior Models*

Traffic models are needed to evaluate the effects of countermeasures on traffic flow and on road capacity. Most traffic models do not replicate the driver behavior at intersections.

- How do countermeasures at one intersection affect the flow at other local intersections?
- How can one understand and compare the effects of vehicle-infrastructure cooperative based countermeasures with vehicle-to-vehicle and vehicle-to-driver based countermeasures on traffic? Vehicle based systems may have profound effects on traffic behavior.

Questions on *Cost-benefits and Trade-off Analysis*

Limited budgets among DOT's and limited budgets among the vehicle buying public constrain the types of solutions that are possible. We must identify the underlying costs that are associated with the countermeasures.

- What benefits can be identified with the proposed countermeasures and how are their costs borne?
- How can we determine which countermeasures are most likely to reap the most benefits with the least new incremental costs?

- What costs are acceptable for IDS deployments at intersections of varying character (different traffic volumes and speed, crash histories, and urban/suburban/rural settings)?

Questions on *Evaluation of Commercial-Off-the-Shelf (COTS) Technologies*

In order to ensure reasonable timelines on deployment, it is necessary to use COTS systems as much as possible. There are two levels of COTS systems that will be considered. The first represent new systems that take advantage of COTS subsystems, such as radar, imaging, GPS, wireless and display systems, but require new software that integrates these into a working system that serves as a part of a countermeasure. The second are represented by turnkey COTS intersection crash prevention systems that are on the market but have not received wide attention.

- Which COTS systems will satisfy IDS requirements?

As further context, the focus of IDS is on vehicle-to-vehicle crossing path collision (which includes straight crossing path, as well as turning movements). Two other participating universities have focused on intersection traffic control device violation (Virginia Polytechnical University, Virginia Tech Transportation Institute) and left turn assistance at stop-controlled minor roads intersecting with high-speed interregional corridors (University of Minnesota, ITS Institute).

The PATH technical focus – requested by our IC partners and agreed upon us because, indeed it represents a major crash problem – is left turn movements with focus on urban and suburban applications. In particular, we concentrate on preventing crashes that occur when a driver makes a left turn onto a cross street, and is either hit head-on by an oncoming vehicle traveling in the opposite direction. Figure ii illustrates the first scenario, dubbed Left Turn Across Path/Opposite Direction (LTAP/OD). The LTAP/OD scenario represents 27.3% of intersection crashes, and cuts across all causal factors.

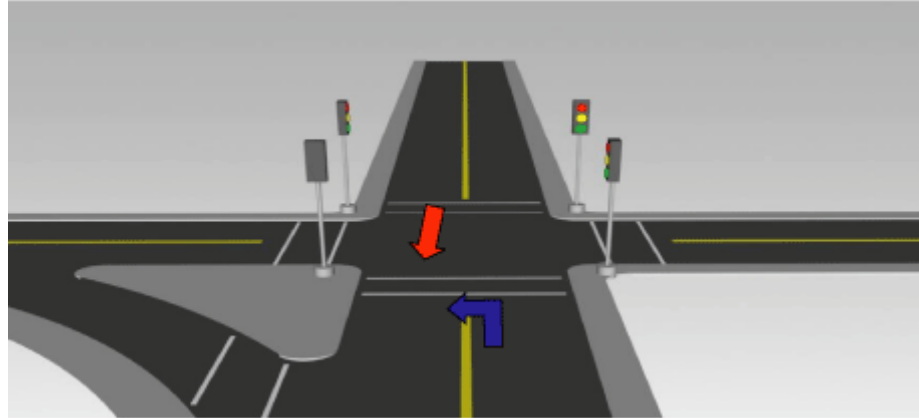

Figure 0.2 LTAP/OD Scenario. Blue Arrow Represents Subject Vehicle, and Red Arrow Represent Principal Other Vehicle

Even with the specific IC-prompted interest in LTAP/OD, our overall effort is deliberately systems-oriented and transcended an infrastructure-only IDS solution. To begin, our point of view is that the national problem is the California problem, so we preferred not to focus *a priori* on a specific scenario or problem type. Our approach at inception was a systems-oriented one; therefore, we have investigated key enabling technologies, most notably *cooperative* infrastructure-to-vehicle (or vehicle-to-infrastructure) and vehicle-to-vehicle communication. We have also begun investigating the use and usability of roadside-mounted “driver-infrastructure interface” (DII). We have put these together preliminarily in a LTAP/OD demonstration, given in June, 2003 at the FHWA Turner-Fairbank Highway Research Center (TFHRC) in McLean, Virginia.

Based therefore on the ten fundamental questions, the agreed focus on LTAP/OD and our systems interest, we constructed an overarching three-year California IDS research plan in nine tasks A – I, shown below with a tenth task, Task M, which was agreed upon by the IC after the project began:

Task 0: Management and Planning

Task A: Delineate the Intersection Crash Problem

Task B: Develop Top Level Requirements for Types/Classes of Intersection Crashes

Task C: Conduct Enabling Research & Development

- Task D:** Prioritize Classes of Intersection Crashes for Initial Study
- Task E:** Conduct Countermeasure Trade-off Analyses
- Task F:** Develop Detailed Requirements and Specifications for Each Countermeasure/Crash Class
- Task G:** System Design and Development
- Task H:** Conduct Subsystem Tests and Experiments
- Task I:** Prepare for Countermeasure Demonstration
- Task M:** Midterm Demo

This Task Order 5600 addressed the first year of the overall effort; hence, the final report addresses the following subset of the total task list, all covered the first year:

- Task A:** Delineate the Intersection Crash Problem
- Task B:** Develop Top Level Requirements for Types/Classes of Intersection Crashes
- Task C:** Conduct Enabling Research & Development
 - Within Task C for this period, we focus particularly on the system architecture, human factors issues to include the Driver-Infrastructure Interface (DII) and initial work in IDS communications tradeoffs.*
- Task M:** Midterm Demo

We describe output and results these tasks in the subsequent sections of this final report. The other tasks are addressed in out-years and subsequent task orders. Indeed, with the work reported herein, we have set the stage for subsequent tasks, with specific future accomplishments to conduct naturalistic driving data collection, perform driver modeling, develop an integrated IDS simulation approach, and to look at the applicability of a large set of already- or nearly-available “commercial off the shelf” systems toward meeting IDS requirements – all of which will be done in subsequent years, following a Caltrans-approved “rebaselining” (or rearrangement) of tasks, based on significant lessons learned from the work reported here.

1 SUMMARY OF IDS RESEARCH

Much progress has been made during the past few years of IDS project work in improving understanding of intersection crashes and how to help drivers avoid them. This work has also enhanced our understanding of what we do not know but still need to learn in order to be able to deploy effective CICAS. Some of these categories of lessons learned and knowledge gaps fit within the class of enabling technology gaps, but others are considerably broader than technology, and address more general knowledge about relevant institutional issues and driver behaviors at intersections.

1.1 Summarizing the key technical lessons learned from our IDS research:

- Intersection designs and operating conditions are so diverse that they cannot be addressed by a single “one size fits all” CICAS design. Rather, it will be necessary for the CICAS design to be flexible and its parameters adjustable to accommodate this intersection diversity.
- Intersection turning conflicts involve complicated combinations of movements of multiple vehicles, all of which need to be detected and tracked in order to assess the severity of potential conflicts. The drivers of the turning and approaching vehicles can normally see each others’ vehicles and respond to their presence and movements by adjusting their own driving patterns. This means that these vehicle trajectories are changing dynamically throughout the intersection encounters and the CICAS detection systems need to be able to track these changes with sufficiently frequent updates.
- Pedestrians and bicyclists are important and vulnerable users of urban intersections, and have significant influences on the behavior of drivers turning at those intersections. The pedestrians and bicyclists need to be detected and tracked by urban CICAS in order to ensure that their safety is not adversely affected by CICAS countermeasures that are intended to help vehicle drivers, and

the messages that CICAS provide to drivers need to be designed to help them avoid hitting pedestrians and bicyclists as well as other vehicles.

- Conventional traffic surveillance technologies are designed to detect aggregate traffic flow conditions rather than individual vehicle movements. These are not generally adequate to meet the CICAS safety needs, which require low-latency measurements of the locations and speeds of the individual vehicles approaching the intersection. Some of the COTS traffic surveillance products could potentially be used with modest modifications to their installation and software, pending the results of current tests of those COTS products.
- As an indication of the detection range needed for CICAS at signalized intersections, it is necessary to detect approaching vehicles at least 6 seconds before they reach the intersection. This means that the detection range in meters for any specific intersection should be defined as 6 seconds multiplied by the maximum speed of approaching vehicles in meters per second.
- The wireless communication link between vehicles and intersection infrastructure that is necessary to put the first “C” in “CICAS” should be technically feasible using the new generation of DSRC systems currently under development, provided that their implementations are designed to be adjustable to accommodate the demands imposed by worst-case traffic density conditions.
- The IDS project work makes possible the design of a first prototype CICAS for testing on a limited scale, using knowledge gained from human factors tests under controlled conditions and from simulations of other conditions, to define the system characteristics for one specific type of intersection. This will need to be tested in a “pilot FOT” to determine how drivers react to it in real-world traffic conditions before strong conclusions can be drawn about its effectiveness for that specific type of intersection. Further work will be needed to identify how it needs to be modified to be effective at other types of intersections.

Another set of non-technical lessons have been learned about the institutional environment in which CICAS will have to be deployed:

- Existing intersections, using conventional technology, are already very expensive to install (at least \$200 K each). This has both positive and negative implications for CICAS deployment. On the one hand, it represents a very large legacy investment that cannot be changed abruptly, and its owners are going to be reluctant to declare it obsolete. On the other hand, the cost of the additional equipment and software needed to add CICAS capabilities is likely to be much less than the cost of the intersection, so it could be easy to justify the incremental cost based on any appreciable improvement in intersection safety.
- The legacy traffic control infrastructure at intersections is extremely diverse in its capabilities, design and interface standards. Because it also represents such a large legacy investment it is likely to change very slowly on a national scale. This means that the CICAS designs will have to be adaptable to interface effectively with diverse existing intersections/
- Ownership of intersections is extremely diverse, meaning that many different jurisdictions need to be engaged in consideration of CICAS in order for it to become widely deployed. This ownership can include state DOTs, as well as counties, municipalities and special districts (such as Congestion Management Agencies in California).
- Traffic engineers have shown strong and positive interest in the concept of dynamic roadside displays to address intersection safety issues, but at the same time they are wary of possible unintended consequences if drivers do not respond “correctly” to these displays. They are also concerned about the liability consequences of systems that fail to eliminate all intersection crashes or even possibly contribute to the creation of new intersection crashes. In many ways,

their situations and attitudes are directly analogous to those of automotive engineers who are addressing the same issues from the in-vehicle perspective.

- The national process of certification of traffic control devices via the MUTCD is an important element in the preparation of CICAS for deployment. The scrutiny that traffic control devices receive through the MUTCD approval process requires the developers to demonstrate significant evidence of benefits without unintended adverse consequences. It also helps ensure the safety of new systems and provides a liability shield for the jurisdictions that choose to deploy the systems.

Despite the extensive knowledge that has been gained to date, there are still important knowledge gaps that need to be filled regarding both enabling technologies and the broader system design issues. In the enabling technologies, there are important gaps in the following categories:

1.1.1 Traffic Signal Controllers and Cabinets

The main technical challenge that remains to be addressed is ensuring that the CICAS hardware and software can be interfaced successfully with the diverse existing legacy traffic control systems, to include software and cabinets. In addition, it would be useful to investigate alternative approaches to avoiding intersection conflicts by using the CICAS state map information for dynamically adjusting signal phase transitions (e.g., green extensions, early amber, all-red extensions, perhaps combined with photo enforcement).

Specific gaps in traffic controller and cabinet technology that need to be remedied for widespread deployment of CICAS at signalized intersections include:

- Development of standard break-out boxes to allow faster processors implementing CICAS algorithms to be installed in cabinets where the traffic signal controller cannot support direct communications or internal integration.

- Support for DSRC wireless antennas as part of traffic signal controller cabinet design, and of DSRC devices that are hardened for the heat and possible power outages of the cabinet environment.
- Development of software interfaces that bridge the traffic signal controller's internal representation of the intersection as a set of conflicting or non-conflicting traffic movements, and the individual vehicle's focus on the lane it is occupying and the traffic light in front of it.
- Development of inexpensive, low-power special-purpose processors for CICAS applications which are compact, include all the required hardened communications support for wireless communication, for sensor communication and for communication to the controller.

In the long run, such devices may be superseded by an integrated traffic signal controller that includes all the functionality of current traffic signal controllers, plus the extra communications and sensing capabilities of the CICAS processor. But in the short run, it will be difficult to integrate the tried and tested capabilities of the traffic signal controllers with new communications and sensing functions that seek to leverage technologies developed for less safety-critical applications.

1.1.2 Sensors and Detectors

We always want to have sensors with higher accuracy and lower latency that are cheap and easy to install, but these attributes always involve complicated practical trade-offs. There do not appear to be any fundamental questions about technical feasibility of detection of approaching vehicles, but there are questions about how far it is possible to go in each of the desirable directions of sensor performance without increasing costs to unattractive levels, particularly when constrained to commercial off-the-shelf systems in use by the traffic engineering community – but for distinctly different and less-stressing applications than CICAS.

The one detection topic that is likely to need some significant new development effort is the detection of pedestrians and bicyclists at intersections, particularly

distinguishing between “safe” and “unsafe” movements of these vulnerable road users relative to the vehicle traffic at intersections. Apart from sensor cost reduction, the largest technical challenge is likely to be in improving methods of data fusion, so that the information from a variety of infrastructure sensors can be combined with information communicated from cooperating vehicles to produce the most accurate possible state map of the intersection. Some initial work is being done on this during the current IDS project, but more will need to be done to develop the most generally applicable approaches, to encompass the full range of expected sensor systems.

1.1.3 Threat Assessment Algorithms

The set of knowledge gaps that needs to be filled with regard to threat assessment are, primarily associated with understanding the human factors issues associated with driver behavior at intersections and driver responses to the information that CICAS will provide to them. These center around developing an in-depth, quantitative understanding of individual driver decision making at intersections, so that the CICAS information can be provided to drivers in the most effective format and at the most appropriate time. This includes issues such as:

- criteria that drivers use in deciding whether or not to make a turn under a given set of conditions (especially relative to gaps in approaching traffic)
- timing of driver decisions about making turns or about proceeding through an intersection when a signal is changing
- identifying underlying intersection crash causality
- assessing driver responses to diverse CICAS messages and message timing, under a wide range of controlled test conditions, in order to distinguish between effective and ineffective CICAS alert system characteristics, including differing combinations of infrastructure-based and vehicle-based information displays
- identifying the acceptability to drivers of varying levels of variability in the CICAS alert criteria and timing (this has a vital influence on the

CICAS accuracy and repeatability, and especially the sensor performance requirements).

A related issue is developing a comprehensive, in-depth, quantitative description of intersection driving behavior at a more aggregate level, so that CICAS design parameters can be adjusted easily and efficiently to apply to a new intersection, without requiring a new research project to address each new intersection condition. This includes issues such as:

- Effects of variations in intersection geometry, traffic patterns (speed, density, pedestrian activity), weather, visibility, signal cycles, etc.
- Collecting and analyzing a sufficiently comprehensive and diverse set of intersection driving behavior data to be able to support the development of “handbook” guidelines for traffic engineers to tune CICAS parameters to suit the needs of specific intersections.

1.1.4 Displays to Drivers

A significant issue is that it is still necessary to refine the message content and timing in order to ensure maximum effectiveness and minimum potential for imposing a nuisance on drivers. Separate, parallel, approaches to message content have been developed during the current IDS projects, but we should expect that in the future it will be necessary to develop a unified concept of information transfer to drivers and a set of displays that will be readily recognized by drivers to be associated with the same general issue of avoiding intersection conflicts and crashes. It will be particularly important to extend work on how to coordinate the in-vehicle and roadside information displays so that they are at least compatible with each other, and hopefully mutually supportive, but not perceived to be inconsistent or confusing by drivers.

Specific driver interface research needs would be to design a display that properly communicates the CICAS intent, satisfying dimensions of perceptual

effectiveness, appropriate message content and comprehension, consistency of message, correct timing, and ultimately, being acceptable to the driver.

1.1.5 Wireless Communications

The emerging next-generation DSRC technologies should generally be appropriate for the CICAS application, but there are still some important gaps to be filled. Fortunately, progress can be made on filling most of these even before a definitive concept of operations and architecture are nailed down, because the issues are sufficiently broad and general that they will be relevant regardless:

- Determine DSRC communications requirements at an intersection under high, medium, and low density traffic conditions to identify protocol design trade-offs and develop recommendations for the most suitable protocols to implement.
- Devise strategies for dynamic power and data rate control. Much of network theory begins by assuming that each node is aware of its neighbors, and that the network topology is more or less constant. Unfortunately due to the ad-hoc nature of networks involving moving vehicles, network topology changes rapidly. Some combination of dynamic power and data rate control needs to be performed in order for the network to maintain reliable service at the node densities that will be observed at intersections. Furthermore, intersection safety messages can be sent at the safety or safety of life priority levels defined by the FCC. Therefore there is a need to design protocols able to guarantee priority communication of intersection safety messages.
- Design and test MAC layer protocols for DSRC that will support the CICAS applications under high-density traffic conditions. These protocols will switch seamlessly from asynchronous operation outside the range of intersection

- transmitter to synchronous operation coordinated by the intersection transmitter as vehicles enter the intersection zone. Testing should include as a large a number of radios and vehicles as practicable in order to provide assurances of performance under realistic operating conditions.
- Finalize definition of data packets for each mode of CICAS operation and present them to the appropriate standardization bodies for incorporation into the DSRC standards development process (this one does need to follow the concept of operations and architecture decisions).

Finally, and taking a broader perspective, another need for CICAS is identifying the benefits (crash reduction effectiveness, intersection traffic flow improvements) and costs of alternative CICAS approaches, so that they can be compared to conventional traffic engineering alternatives. These will be essential to support the definition of warrants for the deployment of CICAS in “competition” with the other alternatives, so that traffic engineers can apply CICAS as a regular “tool” among the others in their “toolbox” for addressing intersection problems.

2 INTERSECTION DECISION SUPPORT PROJECT IDS TASK B1 REPORT: PILOT FIELD OBSERVATIONS DATA COLLECTION AND ANALYSIS

2.1 Summary

This section is divided into two main sections: the first section presents findings from a pilot radar-based field observation of real-world traffic that can be used to support the development of IDS applications, and the second section describes a more detailed timing analysis of the results from the video observations.

Safety solutions, utilizing enabling technologies such as sensing, communication, and signal processing, can provide potentially tremendous benefits in reducing roadway crashes by alerting drivers of hazardous situations. One area of great interest is the deployment of such solutions at intersections, which we call Intersection Decision Support (IDS) applications. Signal-controlled intersections in urban settings represent significant roadway junctions where traffic flows accumulate and intersect, and where crashes tend to concentrate due to crossing paths of potentially conflicting vehicles.

Experimental apparatus was set up at an urban signal-controlled intersection to capture the microscopic vehicle motion data. Subsequently, the data was analyzed to yield some general traffic parameters, such as the distribution of speed and distance of vehicles in relation to the signal transition, and other application-specific data, such as the relative movements of left-turn vehicles versus opposing traffic. The derived information becomes critical input for the development and evaluation of warning systems. Through this pilot study and the associated data processing methodologies, a systematic approach was established that could be applied to a variety of environments and scenarios for IDS applications.

The experimental apparatus consisted of video and radar equipment, serving complementary functions for data collection. The video data was analyzed to get the details of the turning time and the exact trajectory of turn, as well as gaps rejected and accepted in the stream of POVs. The analysis was carried out with the help of a video analysis tool developed by PATH.

The mean value for turning time was found to be 3.3 seconds and the standard deviation was 1 second, with higher values being recorded for those observations in which pedestrians were present in the destination crosswalk. Similarly, lower values were recorded for observations in which the SV made the turn “on the fly.” It was further observed that for the intersection of Hearst and Shattuck, no SV driver accepted a gap below 3 seconds and all drivers accepted those gaps above 12 seconds. For the gaps in the range of 3 to 12 seconds, the acceptance varied. The mean value of gap accepted was 8.7 seconds, and the standard deviation was 3.5 seconds.

It may be inferred from the difference in the mean value of gap accepted and the mean value of turning time that usually the entire gap is not taken up for turning, but some ‘buffer’ remains before and after the turn is executed. The large variability in the gap may be attributed to the variability in the buffer. The mean value of the buffer is calculated to be 5.1 seconds, whereas the standard deviation is 2.98 seconds. It is also observed that larger variability in both turning time and buffers were found for observations made when pedestrians were present in the destination crosswalk.

Several key items, all applicable to designing and tuning the warning system, were learned from the traffic observation:

- Typical speed of traffic flow on green: In the pilot study, the range of speed was between 8-14 m/sec (18-30 mph). The speed of traffic flow provides a basis for determining the design range for decision support, in which sensing systems are required to track vehicles approaching within a desired time window. Once a baseline of traffic speeds is established for a specific intersection, a frequent update of traffic monitoring also allows detection of atypical situations such as congestion or vehicles at excessive speeds.

- Distance to stop-line for deceleration on red: In the pilot study, it was found that a majority of vehicles started slowing down at a distance of 50-75 meters from the stopline, with a deceleration of 0.15 g or smaller.
- Decision point to stop on amber: In the collected data set, if vehicles are 25-50 meters from the intersection (2-4 seconds based on average speed) they are likely to slow down when the traffic signal transitions into amber. If vehicles are cruising at the average traffic speeds and are within 25 meters of the stop-line (equivalent to 0-2 seconds), then they are likely to pass through the intersection without stopping. This distance range is sometimes called the dilemma zone, which is a critical parameter for other intersection safety evaluations, such as red-light violation.
- The depiction of a left-turn subject vehicle shows how the radar data can be analyzed to identify the scenarios for a case study of LTAP-OD. However, the tracking of subject vehicles is incomplete because of the orientation of the radar and the direction of travel of the SV. Combining observations from the recorded video images and the calculation of vehicle speed and distance from the radar, the relative motions of subject vehicles versus the POV traffic can be more precisely tracked for the estimation of time gap acceptance and the results will be more meaningful for the case studies.

From the subsequent standpoint of implementation, we learned that an intersection would ideally be instrumented to track all vehicles so that full knowledge of an intersection “state map” can be acquired. However, practical considerations, learned from the experience of our application of measurement instrumentation, are that a combination of ground loop detectors and remote radar sensors can be complementary to each other in a sensing system. The radar can provide real-time data for tracking multiple vehicles with proper signal processing. Due to environmental clutter or signal dropout, radar measurements may be susceptible to a variety of errors. As a result, it could be beneficial to have the loop detectors as backup.

In a ground-based solution, such as using the loop detectors, it is critical that sensing elements be placed at strategic locations. For instance, based on our observation of the pilot study, it can be suggested to install at least double-loop detectors at three different zones at 0-25, 25-50, and 50-75 meters from the stop-line. The sampling of vehicle presence and speed (with double loops) in

the three zones can be very telling of the status of approaching traffic, especially when the measurements are coupled with the traffic signal phase.

2.2 Background

In order to facilitate the studies of various scenarios, field observation studies were conducted on October 2, and December 11, 2003, to collect data to characterize “normal” intersection driving behavior, in turn to be used as the basis for threat assessment and the development of warning system designs. The field study was carried out at an intersection in the city of Berkeley, California, representative of an urban environment. With a combination of radar data representing vehicle trajectories and video images showing the relative maneuvers of vehicles, the collected data was analyzed to establish the relationship between individual vehicle movements and traffic signal phases. Methodologies were also developed to extract safety measures, such as gap acceptance of opposing traffic by drivers making maneuvers in an intersection. Lastly, this pilot study also offers real-world data that can be used for the assessment and evaluation of eventual deployment at candidate sites.

Figure 2.1 on the next page shows a functional diagram of a suggested IDS application. The blue (central) blocks represent the existing infrastructure at an intersection, the purple (left) block indicates the added equipment for IDS, and the red (second left) block is an optional wireless communication system that can be incorporated into the larger IDS system. Among the IDS subsystems, sensors are utilized to supplement the existing traffic monitoring devices to capture the information about traffic flow, which is fed into signal processors and safety algorithms. The IDS application may include the use of a newly implemented driver-infrastructure interface (DII). The activation of the DII can be alternatively triggered by traffic controllers or the IDS processors or computers. The actual composition and the exact functionality of subsystems and the overall IDS warning system will depend on the specific applications and the corresponding traffic scenarios. For example, a “dynamic” DII displaying a flashing no-left-turn sign was proposed as a countermeasure to alert drivers of hazardous situations in a left-turn across-path opposite-direction scenario. [2-4]

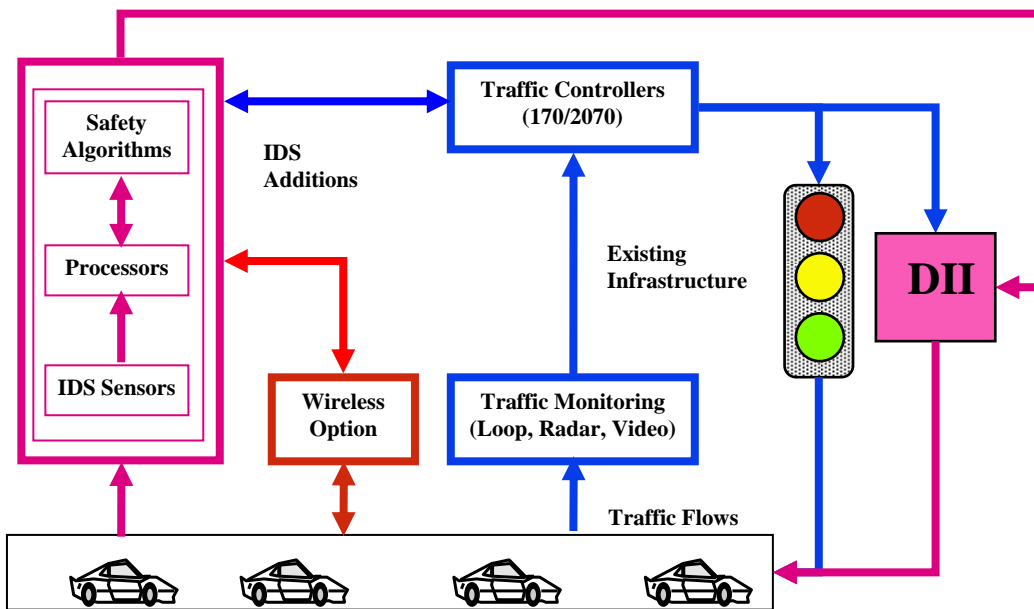

Figure 2.1 System Architecture and Functional Diagram of IDS Safety Solutions

2.3 Description of Traffic Observation Study

The selected intersection is located in a section of downtown Berkeley, where there is traffic throughout the day. During a typical daytime signal cycle (75 seconds), there are 10-20 vehicles passing through that intersection in each direction. Various retail businesses are operating near the intersection and there is a consistent level of pedestrian and bicycle traffic.

In the north-south direction (Shattuck Avenue), there are two regular traffic lanes in each direction and a curbside lane for parking. Near the intersection there are left-turn pockets that begin about 30 meters before reaching the intersection and that represent a third lane at the intersection in both directions. There is a narrow island median at the center of the street separating the traffic in opposing directions. In the east-west direction (Hearst Street), there are also two lanes of regular traffic in both directions.

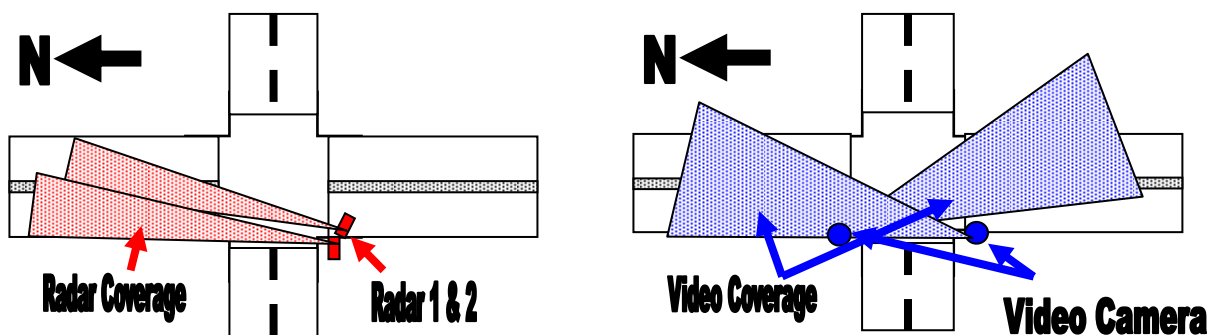

Figure 2.2 Radar and Video Camera Orientation at the Observation Site

There are traffic signals controlling all directions of traffic, and pedestrian signals for the crosswalks. The traffic signal cycle was fixed at 75 seconds during the time of observation. In the north-south direction, the green phase is 34.1 seconds, followed by 3.3 seconds of amber, then the rest in the red phase, with a 2-second all-red phase.

The observation study was on the traffic flows in the north-south direction. Two Eaton-Vorad radars (EVT-300, Specifications given in Appendix A) were mounted at the back of a van that was parked at the southwestern corner of the intersection. See Figure 2.2 for a depiction of the experimental setup. Two video camcorders were set up at the northwestern and southwestern corners of the intersection. The video camcorders and the radar data acquisition system were synchronized beforehand. The phase of traffic signals was synchronized with other data in post-processing. About 100 minutes of video and engineering data were collected in one field trial, and two hours of data on a second field trip. On the second trip, one unit of radar was relocated to be near the second video camera. The follow-up data evaluation is primarily based on radar data, which monitors the traffic streams along the monitored direction, and the supplementary video images to help identify specific vehicle maneuvers.

2.4 Data Descriptions

The data collected from the radar in their raw form are expressed in a polar coordinate system. See Appendix A for an explanation of the necessary transformation to convert the measurements into a ground reference coordinate system.

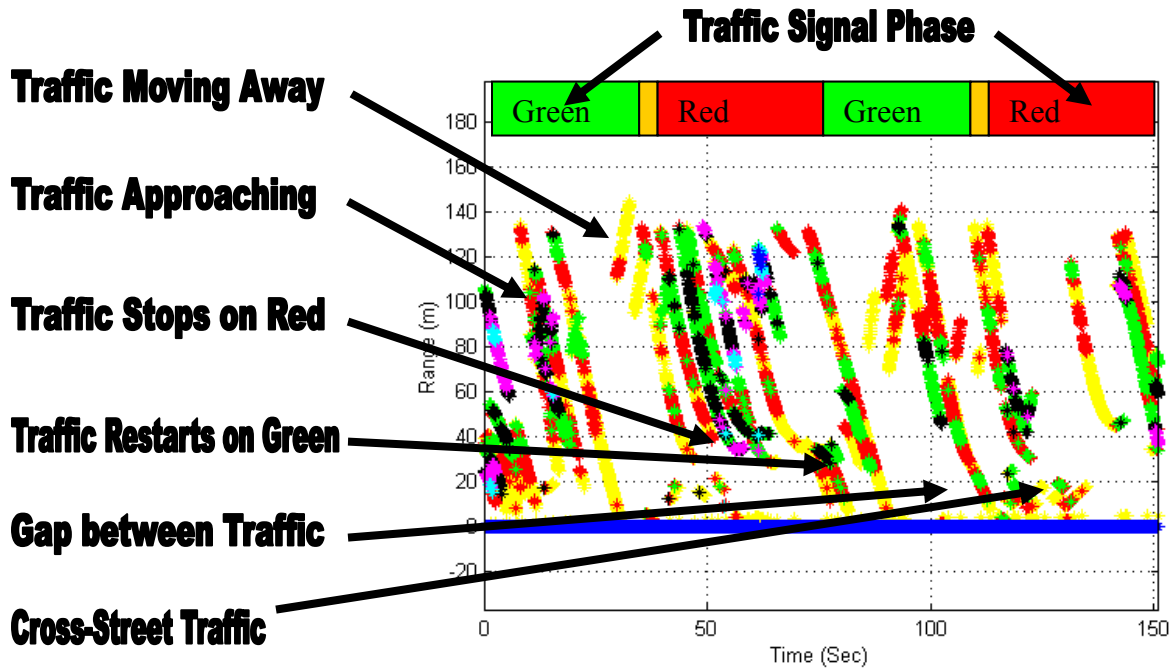

Figure 2.3 An Illustration of Radar Data over Traffic Signal Cycles

Figure 2.3 illustrates the radar data with target ranges plotted against time. In the graph, a set of data for 150 seconds was plotted, which accounts for two cycles of traffic signals in the Shattuck direction. The color bars at the top of the graph show the signal phase. Traces of targets detected by the radar are shown in the graph. Since the radar can detect up to seven targets, different colors are used to mark multiple target information. The flip-flopping of colors within individual traces, which is often from one same target, is caused by a preset scheme of data output from the radar.

Several characteristics of the data patterns in Figure 2.3 are noted here:

- Targets approaching the intersection in the middle of the green phase move at roughly the same slope (speed), which means they are cruising if there is no congestion.

- Since the radars with field of view of 12 degrees were set up at the southwestern corner, southbound vehicles would disappear from the radar field of view when they were mid-way through the intersection.
- Since the EVT-300 is a Doppler-type radar, vehicles stopped on red before the stopline disappear after a couple of seconds. The north stopline is located approximately 27 meters from the radar antenna.
- The vehicles that are moving in the cross direction (on Hearst) during the red phase would show up as brief traces as they move in and out of the radar field of view at a distance of 5-20 meters.
- Targets that are moving away in the northbound Shattuck direction also show up in the graph, and their traces have a positive slope as the range increases over time.
- Vehicles making a left turn from northbound Shattuck onto westbound Hearst show up at a distance of about 14-20 meters. This particular pattern is used later on to extract incidents of left-turn vehicles for a case study.

2.5 Traffic Flow Patterns versus Signal Phases

An IDS safety application will require the assessment of relevant vehicles approaching the intersection. Based on the estimation of arrival times of involved vehicles, a warning can be

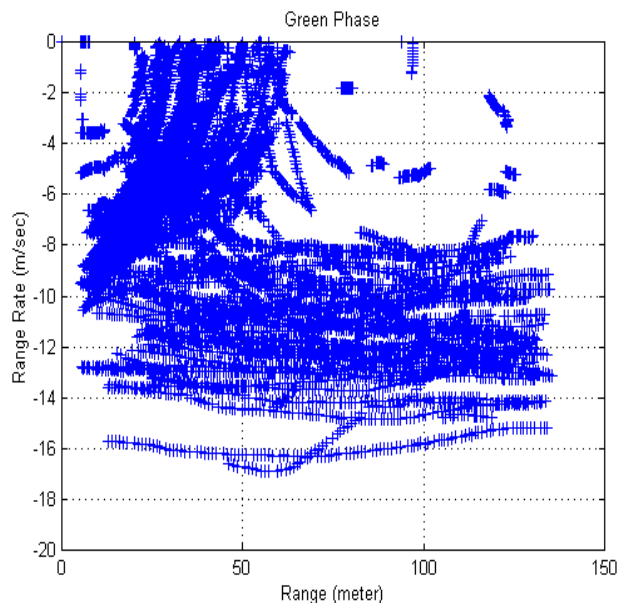

Figure 2.4 Range vs Range Rate in Green Phase

issued to alert the drivers. The movements of vehicles, however, are affected by several factors, including intentions of individual drivers, traffic conditions, and particularly traffic signals in signal-controlled intersections, of which the intersection of our observation studies is one. Therefore, it is important for us to understand the behaviors of traffic reacting to the signals. In this section, we use the collected data to show the traffic patterns in the transition of signal phases.

The range and range rate data generated by the radar need to be converted into a local coordinate system to calculate the corresponding ground distance and speed of the target vehicles. In our experimental setup, the boresight of the radar is oriented with a small angle relative to the traveling direction of traffic; therefore, the direct use of range and range rate represents a good approximation of the traffic states.

A state-space plot of multiple-cycle aggregate data in the green phase is shown in Figure 3.4. It can be seen that a cluster of vehicles are moving at a range rate of 8-14 m/sec. In the upper left

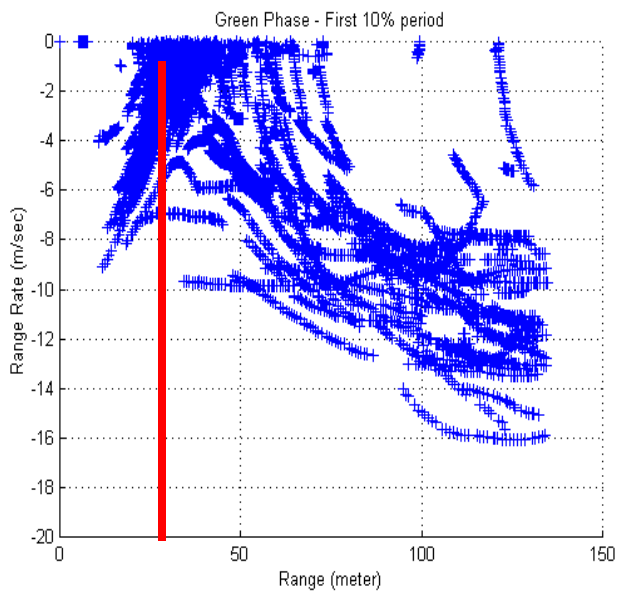

Figure 2.5 Green Phase – 1st 10%

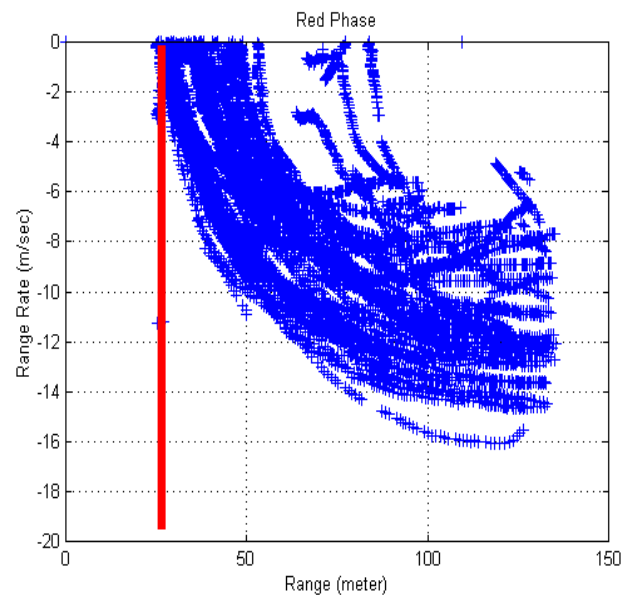

Figure 2.6 Range vs. Range Rate in Red

quarter of the chart, vehicles can be seen moving from their stopped positions from the previous red phase and increasing speed as they move across the intersection. This segment of data is further depicted in Figure 3.5, which is a set of aggregate data of over 90 minutes of traffic in the first 10% of the green phase, where vehicle movements indicated that lead vehicles held from the previous red phase (range of 25-50 meters) are accelerating as the signal changes to green while trailing vehicles (range 50-100 meters) are decelerating to a stop behind the leading vehicles at the intersection.

For an observer of the approaching traffic, targets present a threat if they are close in distance or in time. The patterns as presented in Figures 2.4 and 2.5 reveal that both measures should be evaluated jointly because targets may be close in time or distance but each measurement alone is not a direct indicator of threat.

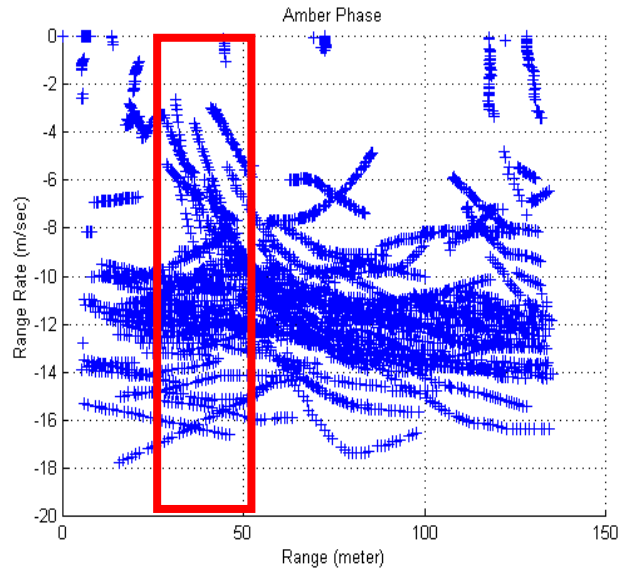

Figure 2.7 Range vs. Range Rate in Amber Phase

In contrast to the green phase, data from the red phase looks distinctly different as shown in Figure 2.6. As shown, vehicles approaching the intersection begin to decelerate at a range of 75-100 meters and come to a stop behind the stop line. For traffic patterns in the red-phase traffic, it will be of great interest to analyze when and where the approaching vehicles begin to slow down so that potential red light violators can be differentiated from normal traffic that is decelerating near the stopline.

The importance of observing traffic patterns during the phase transition is particularly amplified in the amber phase, such as the data depicted in Figure 2.7. Drivers may choose to move across the intersection or to slow down when they are in the so-called dilemma zone. The graph shows that if the vehicles are within 20-25 meters of the stopline, or about 2 seconds of travel time, most of the vehicles appear to move ahead and cruise through the intersection when the signal is transitioning from green to amber. Otherwise, vehicles would have started decelerating before they reach the dilemma zone as they anticipate the red signal. For example, many targets can be seen decelerating in the 50- to 75-meter range. The braking rate was harder if the vehicle is closer to the stopline, and milder if it is farther away.

2.5.1 Detection of Left-Turn Vehicles versus Opposing Traffic

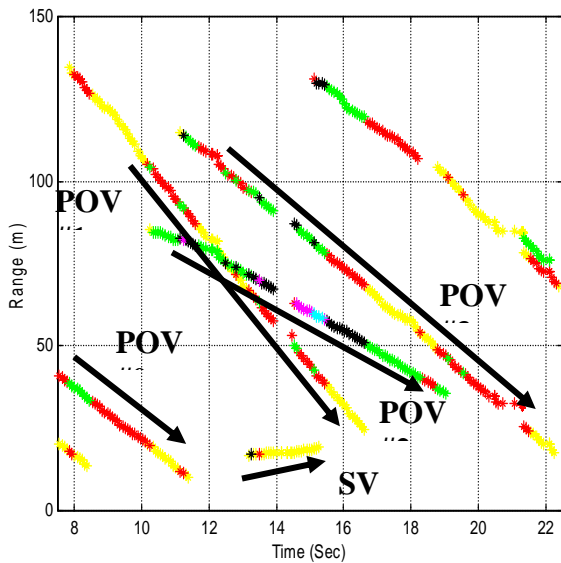

Figure 2.8 Range Data of a Left-Turn SV

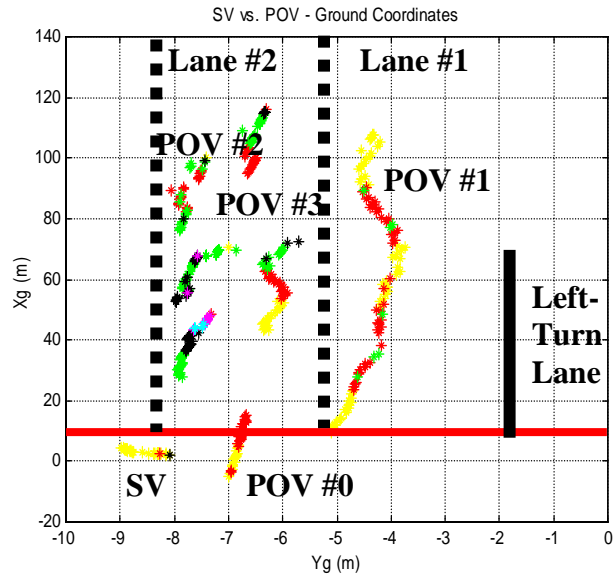

Figure 2.9 Trajectories in Ground Coordinates

One IDS application aims at left-turn across-path opposite-direction (LTAP-OD) conflict situations, in which the subject vehicle (SV) attempts to make an unprotected left turn while facing the potential threat from the traffic in the opposite direction. The observation study, with experimental setup as suggested above, allows the capture of these cases. In this section, we use the collected data to illustrate methods of analyzing these situations.

A vehicle (SV) making a left turn in the intersection, opposite the traffic flow observed by the radar, will show up briefly in the coverage area of the radar. Figure 2.8 depicts such a scenario from a selected data segment. Each arrow in the drawing indicates a target detected by the radar. Note that the SV appears after Principal Other Vehicle (POV) #0 has passed through the intersection at $t=10$, while POV #1-3 approach later. It turned out, as revealed by video review, that POV #2 was actually a bicycle and it stayed in the same lane as POV #3 in their movements toward the intersection.

An alternative view of the scenario is shown in the ground space of Figure 2.9, with the origin located at the center point of the intersection and the x and y coordinates defined as those

explained in Appendix A. The SV was not detected by the radar until the later portion of its left turn as it emerges behind POV #0 after the latter passes through the intersection.

Once the locations and trajectories of all these vehicles are defined in the ground coordinates, their distance and time-to-intersection can be properly calculated. By extracting all applicable scenarios from the collected data, the distance and time gaps between the POV traffic and the SV turning time can be used to derive the characteristics of SV driver behaviors in the incidents of interest and provide a real-world basis for the development of warning criteria.

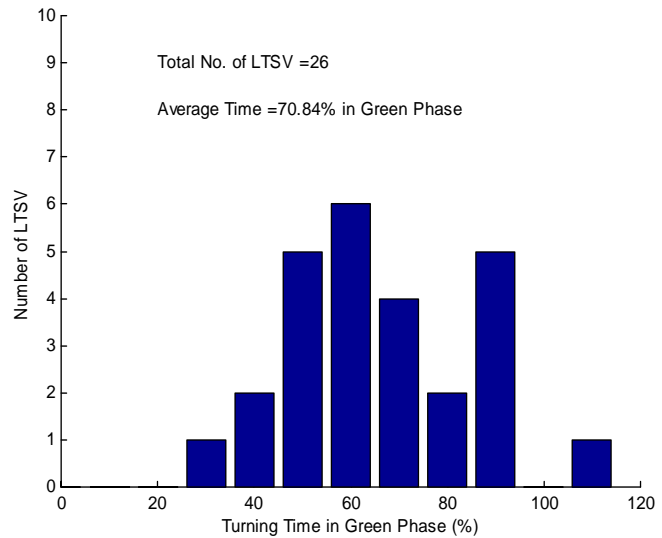

Figure 2.10 LTSV Turning Time in Green Phase

For the design of IDS solutions, it is also critical to determine whether the behaviors of drivers change due to variations of the traffic volume and signal phases. For example, in heavy traffic left-turning vehicles are likely to wait until the later portion of the green phase or even the amber phase to make their turns. It is conceivable that SV drivers will be enticed to take more aggressive actions if the time windows for attempted maneuvers are sparse or short.

By correlating the radar data to the signal phase, the distribution of the SV turning time within the green phase can be analyzed. Figure 2.10 shows such an analysis from a data segment of 100 minutes, within which there are 26 left-turning vehicles. As shown in the graph, there was one case where the SV was detected during the amber phase, thus the time was identified as 110% of the green. The average detection time for all cases was about 71% of the green cycle in this set of data.

2.6 Summary of Traffic Pattern Observations

The traffic observation and the subsequent data analysis can provide the following information, which is applicable for studies of intersection decision support:

- Typical speed of traffic flow on green: In the pilot study, the range of speed was between 8-14 m/sec (18-30 mph). The speed of traffic flow provides a basis for determining the design range for decision support, in which sensing systems are required to cover a desired time window. Once a baseline of traffic speeds is established for a specific intersection, a frequent update of traffic monitoring also allows detection of atypical situations such as congestion or vehicles at excessive speeds.
- Distance to stop-line for deceleration on red: In the pilot study, it was found that a majority of vehicles started slowing down at a distance of 50-75 meters from the stopline, with a deceleration of 0.15 g or smaller.
- Decision point to stop on amber: In the collected data set, if vehicles are 25-50 meters from the intersection (2-4 seconds based on average speed) they are likely to slow down when the traffic signal transitions into amber. If vehicles are cruising at the average traffic speeds and are within 25 meters of the stopline (equivalent to 0-2 seconds), then they are likely to pass through the intersection without stopping. This distance range is sometimes called the dilemma zone, which is a critical parameter for other intersection safety evaluations, such as red-light violation.

In an ideal setting for IDS solutions, an intersection should be instrumented to track all vehicles so that full knowledge of an intersection “state map” can be acquired. However, there are limitations in real-world implementation, and measurements are not available or reliable at all times. Furthermore, a degraded mode of operation will be necessary when certain sub-systems are operated in the limited conditions. Therefore, it will be practical to evaluate sensing strategies with constraints taken into account. For example, a combination of inductive loop detectors and remote radar sensors can complement each other in a sensing system. The radar can provide real-time data for tracking multiple vehicles with proper signal processing. However, due to environmental clutter or signal dropout, radar measurements may be susceptible to a variety of errors. [5, 6, 7] As a result, it could be beneficial to have the loop detectors as backup.

In a ground-based solution, such as using the loop detectors, it is critical that sensing elements be placed at strategic locations. For instance, based on our observation of the pilot study, it could be suggested to at least install double-loop detectors at three different zones at 0-25, 25-50, and 50-75 meters from the stopline. The sampling of vehicle presence and speed (with double loops) in the three zones can be very telling of the status of approaching traffic, especially when the measurements are coupled with the traffic signal phase.

The depiction of a left-turn subject vehicle in the previous section shows how the radar data can be analyzed to identify the scenarios for a case study of LTAP-OD conflicts. However, the tracking of subject vehicles is incomplete because of the orientation of the radar and the direction of travel of the SV. Combining observations from the recorded video images and the calculation of vehicle speed and distance from the radar, the relative motions of subject vehicles versus the POV traffic can be more precisely tracked for the estimation of time gap acceptance and the results will be more meaningful for the case studies.

Another benefit of traffic observation and data collection lies in the potential use of the data in the system design process. With the current collected traffic data, and/or with enhancements from future studies, simulations of alternative criteria for the implementation of safety countermeasures can be tested on selected data sets. The movements of subject vehicles and other vehicles can be used to compare the timing of warning signals to fine-tune the design parameters. Similarly, sensing strategies with discrete or continuous sensors can be compared against the real world for the validation of safety algorithms.

2.7 Time to Intersection (T2I) Analysis

A common element in the proposed decision-support system, for various types of intersections and scenarios, is the prediction of imminent conflicts.

In this section, an approach for synthesizing the traffic streams at an urban intersection and assessing the risk levels is presented. The analysis is based on field data collected at the same urban intersection described in the previous section. Through this study, an attempt was made to establish a linkage between the threat posed by traffic flows and the effects of traffic signals. The

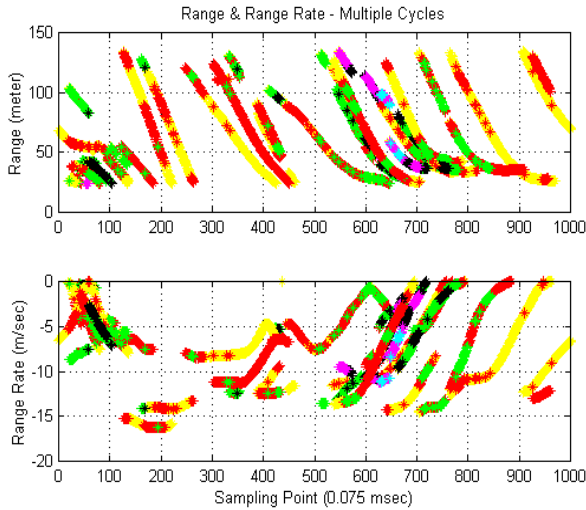

Figure 2.11 Radar Data

the red phase. The different colors of the plotted data reflect multiple targets identified by the radar. Vehicles moving in the departing or the crossing directions were filtered out to make better displays of the targets within the two traffic lanes in the monitored direction. The first half of the cycle was in the green phase and roughly the second half in red. The graph shows that in the initial part of the green phase vehicles gradually gained speed, then traffic was cruising for the remaining green phase before the vehicles slowed down toward the stopline, at

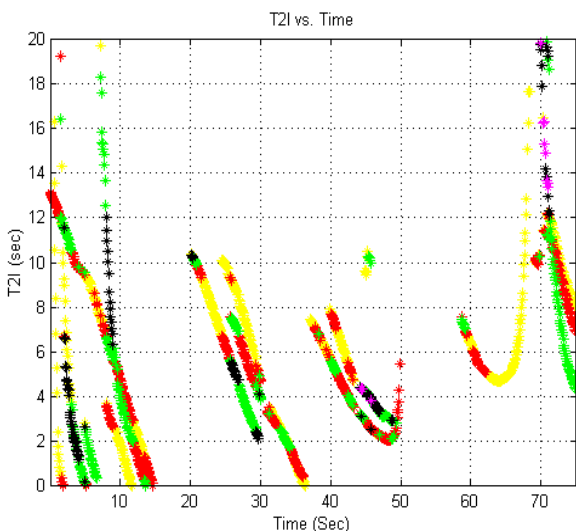

Figure 2.12 T2I Derived from Radar

understanding of such linkages can provide significant inputs for defining the criteria that decide the activation and inactivation of warnings as well as for defining the sensing requirements that support the safety concept.

Figure 2.11 shows a sampling of the range and range rate of radar targets with data from two cycles superimposed. The 1000 points of data sampling starts at the beginning of green and ends at the close of

approximately 25 m, during the red phase.

The raw measurements, expressed in polar coordinates in the radar output, can be converted into a local ground system. Subsequently, the data can be translated into ground speed and distance to selected reference points of interest. Even though the radar device proved to be a powerful tool in our attempt for traffic monitoring, there are certain drawbacks. The radar is a Doppler type, thus stationary targets are filtered out. Microwave also reflects and bounces off

different parts of vehicles, generating nonlinear behaviors at times. Single targets may also appear as multiple targets in one instant. In order to track individual targets clearly over time, some signal processing and filtering are required.

A correct assessment of the threat posed by opposing traffic is essential in the decision-making process for the driver of a subject vehicle attempting to make a maneuver at an intersection. For example, a driver intending to make a permissive left turn will have to judge how fast a vehicle coming from the opposite direction is approaching. In this case, a representation of risk levels can be expressed by time-to-intersection (T2I), which in its simplest form is obtained by dividing the distance to intersection by the target speed at an instant. Figure 2.12 gives examples of T2I variations of multiple targets over one traffic signal cycle, which is the same as previously described. Initially, the T2I values for several targets are high because the stopped vehicles at the stopline are only beginning to move. Then T2I decreases for a batch of targets as they move through the intersection unstopped. In the red phase, T2I decreases as vehicles approach, then increases as they slow down and stop.

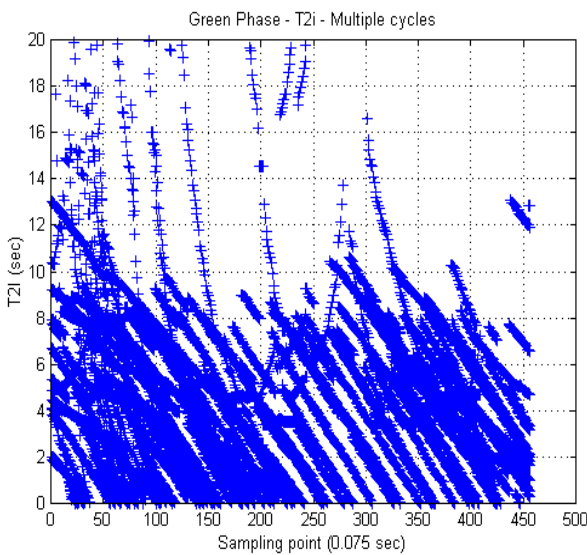

Figure 2.13 T2I in Green Signal

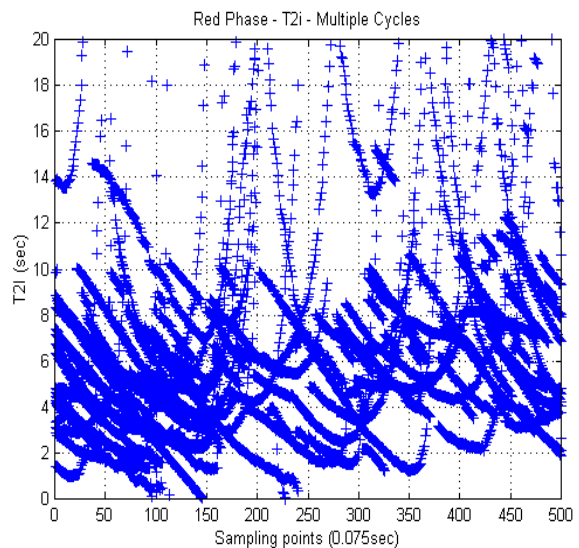

Figure 2.14 T2I in Red-Signal

The aggregate data over multiple cycles can be superimposed to reveal the traffic patterns. For example, it is useful to observe vehicle movements during signal transition at signal-controlled intersections. The T2I data in the green and red signal phases are shown in Figures 2.13 and 2.14. The patterns of traffic movements at various stages of the traffic cycle are clearly visible

and can be described by the following observations: (1) Vehicles stopped or slowly moving near

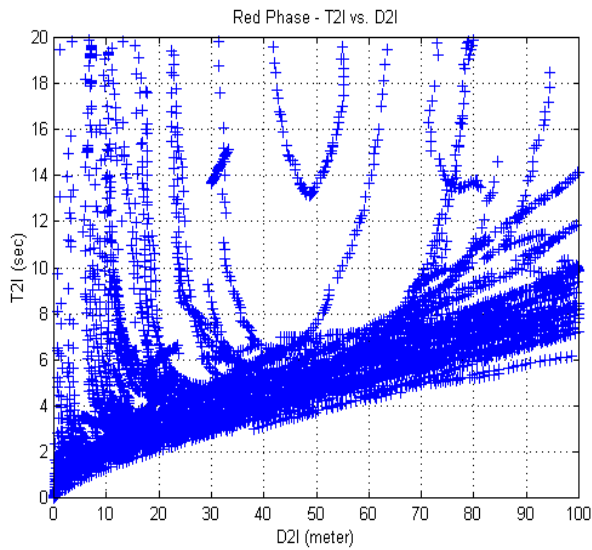

Figure 2.15 T2I vs. D2I in Red Phase

the intersection at the beginning of green and the corresponding T2I values are high; (2) In most parts of the green phase, T2I decreases at constant rates as traffic follows the flow; (3) In the red phase, T2I curves form a sequence of hanging-rope forms as vehicles approach the intersection, slow down, then stop; (4) Traffic accumulates during the red phase and the minimum T2I rises in later arrivals.

Another aspect of data analysis for threat assessment can be presented by reviewing T2I variations as a function of the corresponding distance to intersection (D2I). Figure 3.15 depicts this dimension of data representation for the red signal phase, obtained from the same data as

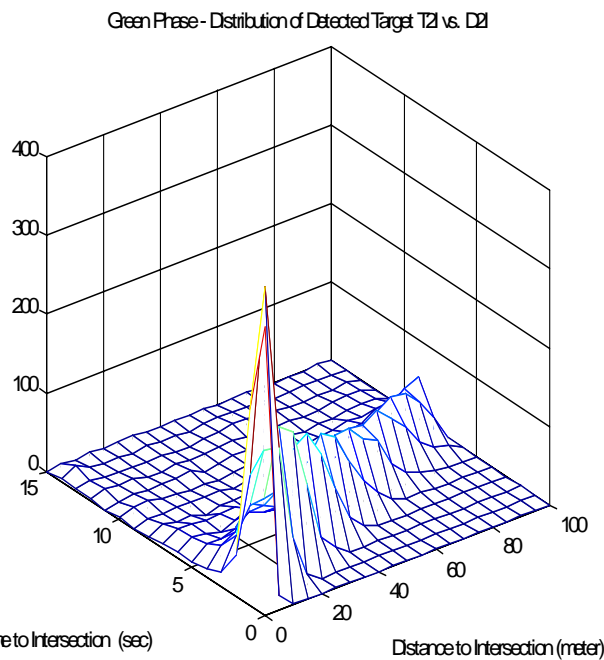

Figure 2.16 T2I vs. D2I in Green Phase

Figure 3.14. Here, T2I and D2I are the time and distance to reach the stopline. It can be seen in this graph that the decelerating maneuvers of approaching vehicles make T2I rise from a range of 2-6 seconds at a distance range of 15-60 meters.

Based on the basic processing of individual targets in the traffic streams, such as those from the previous figures, aggregate data over a considerable period can be accumulated to reveal traffic patterns. Figure 2.16 shows the collective distribution of T2I of all targets versus the distance to intersection (D2I) from multiple signal cycles during the green phases.

These aggregate data provide outstanding background statistics of how traffic approaches the intersection in different signal phases. In the following section, we will use a couple of case studies to illustrate how basic traffic data can be mined to extract useful and valuable information for intersection safety applications.

2.8 Application of T2I Assessment for LTAP-OD Scenarios

One intersection scenario of particular interest is the LTAP-OD conflict. One key issue in implementing an effective advisory or driver-assistance warning for the driver of the subject (turning) vehicle is the determination of a safe and acceptance time gap or distance that allows the described maneuvers. In other words, the question is what the threshold gap size is when the driver of the subject vehicle will accept or reject a gap in the stream of other vehicles and proceed with the intended left turn? It should be noted that it is likely that driver behaviors can be quite diversified and the desired warning will not be perceived as optimal by all drivers. Traffic monitoring at candidate intersections will be useful in identifying the specific characteristics of local driver behaviors. This necessity further highlights the benefits of field observations to provide insights into such issues.

The field observation setup as illustrated in Figure 2.17 conveniently also allows the capture of subject vehicle incidents besides a constant monitoring of opposing traffic stream. Figure 2.17 shows the trajectories of a left-turn subject vehicle (SV marked by blue rectangles) and other vehicles, designated by red circles, within the coverage area of radar. As the subject vehicle crossed in front of the radar boresight, it was detected by the same radar pointing at the other vehicles. Through the use of data processing techniques, these left-turn incidences were scanned automatically from the collected data set for evaluation. By coupling the SV appearance with the

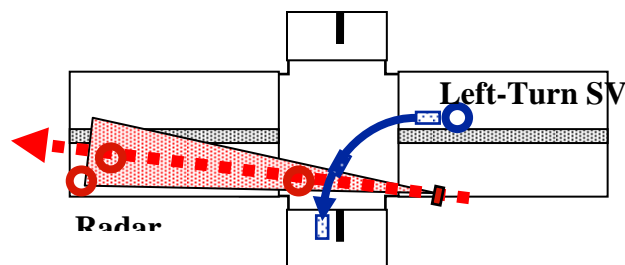

Figure 2.17 Left-Turn SV and Other Vehicles

opposing traffic, the locations and approaching speeds of the oncoming vehicles can be used to investigate the conditions under which drivers decided to initiate a turn.

For example, in a 90-minute stretch of observation, 31 left-turn vehicles were

identified on a field observation trip. Figure 2.18 is an accumulative representation of time gap acceptance by multiple drivers on that date. The T2I of principal other vehicles (POV, the one that is closest to the intersection in time) in both lanes are plotted versus time before and after the appearance of subject vehicles. Aggregately, this shows the relative timing of POV arrival versus the turning maneuver of the SV. Note that in this plot, there appears to be a noticeable window as defined by the two dashed lines except for a few exceptions. Here are a few notes regarding the characteristics of the apparent time window:

- (a) The lower dashed line, which intersects the horizontal time axis at $t = -2$, defines a boundary when the SV turn is initiated relative to the passing traffic stream. In other words, all SVs are detected at least 2 seconds after the previous opposing vehicles have entered the intersection and passed.

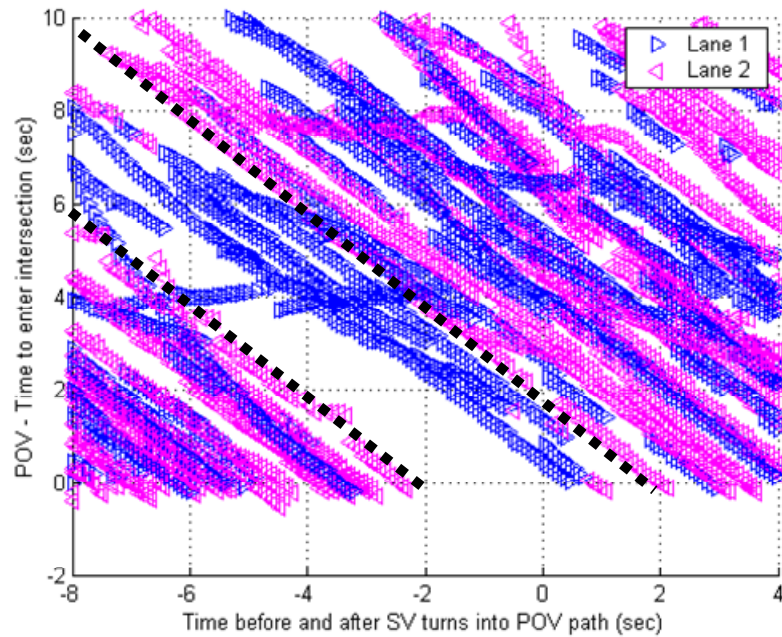

Figure 2.18 Time Gap Selection by LT-SV Drivers

- (b) The upper dashed line, intersecting the horizontal time axis at $t = 2$, defines the boundary where most SV drivers decide to make the turn with respect to the oncoming traffic. For example, when a SV driver makes a decision at $t = -4$, T2I of oncoming traffic is 6 seconds away for most cases.
- (c) One exceptional case, after comparing the radar data to the video data, showed that the POV was cruising toward the intersection and came very close to the SV as the SV was completing the turn. This case is represented by the trajectory (the blue trace) of a POV in Lane 1

crossing near the origin (0, 0) in Figure 2.18. The other cases where the traces of POVs are in the vicinity of the origin also indicated close encounters between SV and POV.

- (d) Upon review of the recorded video, it was found that there were cases when the turning maneuvers of SV were deterred by the presence of pedestrians, including the exception case explained above. This phenomenon adds another layer of complexity for safety solutions in urban areas due to the pedestrian traffic.
- (e) Further review of additional data collected on other field trips demonstrated that there was similar behavior to that exhibited in Figure 2.18. However, when traffic was heavier, the encroachment of POV traces into the time window became more evident. The hypothesis is that drivers may be enticed to take on more aggressive maneuvers if heavier traffic forced them to wait for longer times at the intersection.

2.9 Video Data Analysis

The extraction of the SV movement data from the video images is complicated by the wide variety of driver actions at intersections where pedestrians are crossing. In some situations, drivers proceed dangerously through a left turn at an intersection without stopping; in others, drivers cautiously halt at the stopline, and they wait to turn until there is a suitable gap in the opposing traffic and all pedestrians have cleared the vehicle's projected path. Some drivers gradually move forward into the intersection, while others drive directly into the middle of the intersection before stopping to wait for the desired gap between POV and pedestrians crossing its path.

For the purpose of analysis, the intersection is subdivided into regions in order to facilitate a systematic description of the paths that the vehicles follow, as shown in Figure 2.19.

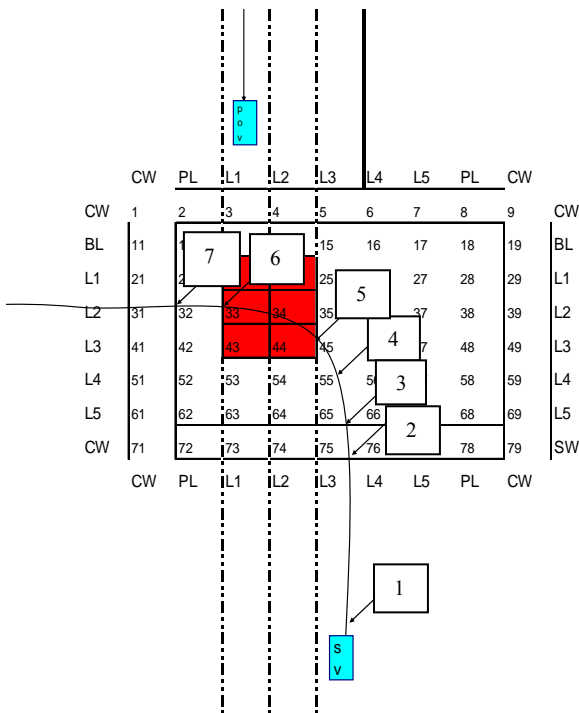

CW=crosswalk, PL=parking lane, BL=bicycle lane and Lx = traffic lane x.

Seven points marked in the turning path of the SV (marked by the seven arrows starting adjacent to the SV)

1. SV entering left-turn pocket
2. SV entering crosswalk (front bumper)
3. SV crossing the inner (into the intersection) line of crosswalk (front bumper)
4. SV shows significant left-turn movement
5. SV encroaches into POV traveled way (front bumper)
6. SV leaves the travel way of POV (rear bumper)
7. SV crosses the inner (into the intersection) line of crosswalk (rear bumper)

Figure 2.19 Extraction of turning times using the observation tool/intersection diagram

To enable the analyst to identify specific times from the video data efficiently (for example to identify the times at which the vehicle is at any of the seven points defined in Figure 3.19), we developed a video “playback” tool. Figure 3.20 displays a screen shot of the playback tool user interface. The tool can be used to modify the speed of the video playback and record the timeline by clicking on the numbered icons. It is essentially a Quicktime video player with variable speed and adjustable frame speed capabilities that allows the analyst to mark the time of events relative to the beginning of the segment of the video.

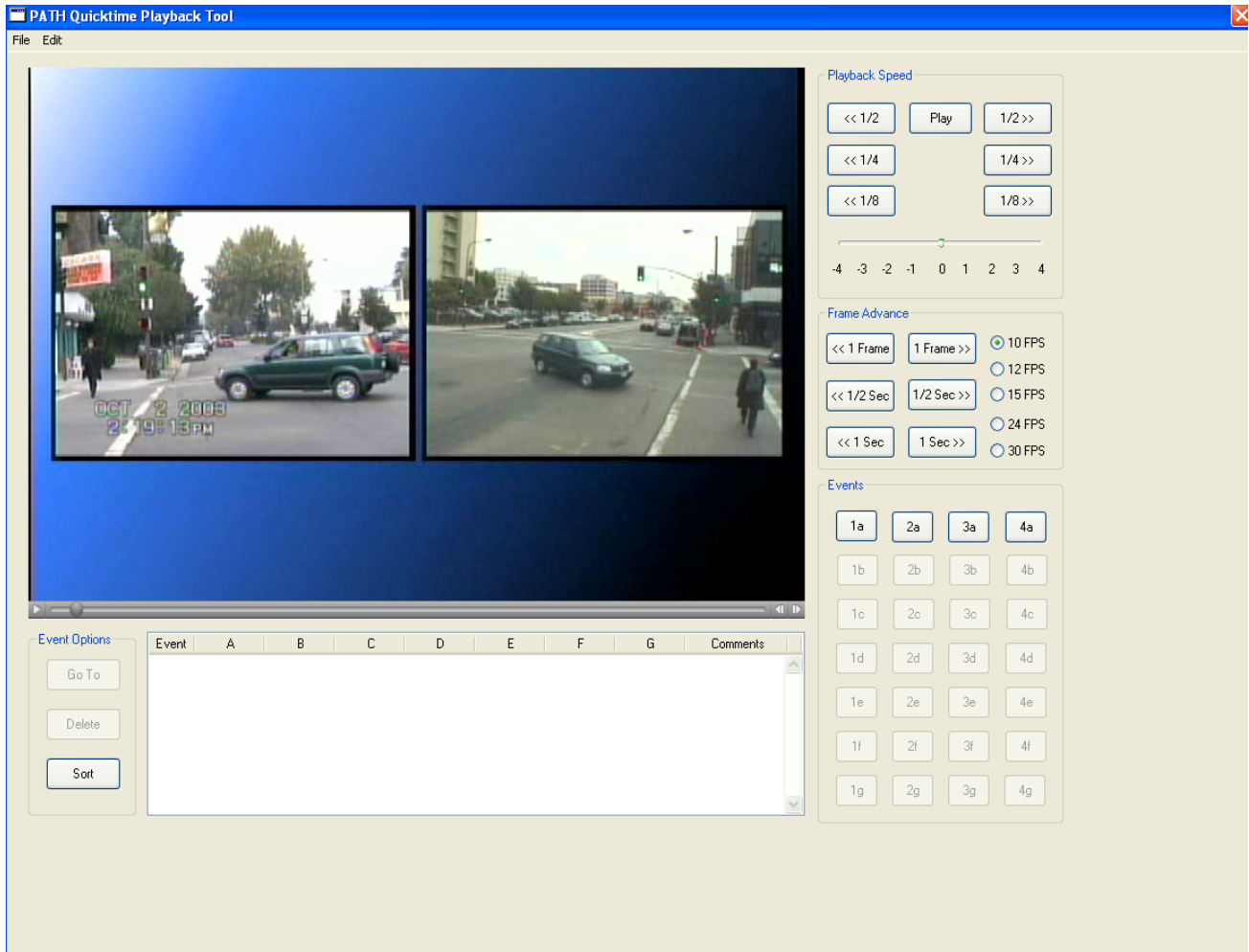

Figure 8.20 Screen shot of video data analysis tool interface

2.10 Data Analysis & Results

While the primary use of the video data is for capturing SV movements, especially those relating to its turning time and gap acceptance behavior, it may be used for validation of the radar data, predicting some POV characteristics, for example, T2I.

Turning Time analysis: Turning time, as defined in this study, is the time taken by a left-turning vehicle to move from point 4 (location 55) to point 6 (location 33) in Figure 2.19. Table 2.1 lists the turning times of vehicles under various circumstances, for instance, in presence of a pedestrian in the destination crosswalk, during late yellow, or when ‘on the fly’.

It is observed that in the presence of pedestrians in the destination crosswalk, the mean and standard deviation of the turning time increase. These are very low, however, when the SV makes a left-turn on the fly, or in yellow or red. For the rest, the mean is very close to the mean

of the total data set. However, the standard deviation is lower. Therefore the standard deviation of the dataset is increased due to the influence of the observations with pedestrians in the destination crosswalk.

Table 2-0-1 Turning Time Under Different Situations

		Turning Time
Overall	# of Samples	109.0
	Mean	3.3
	STD	1.0
Pedestrians	# of Samples	22.0
	Mean	4.4
	STD	1.5
On the Fly	# of Samples	16.0
	Mean	2.8
	STD	0.5
From Queue	# of Samples	11.0
	Mean	3.1
	STD	0.4
Yellow or Red	# of Samples	27.0
	Mean	2.9
	STD	0.5
Remaining Observations	# of Samples	41.0
	Mean	3.1
	STD	0.5

2.11 Gap Acceptance:

An accepted gap in the analysis is defined as time between POV passage (rear bumper of that POV) of a fixed point in the intersection immediately before SV starts and completes its turn and the time of arrival of the next POV (judged by the front bumper) immediately following the POV described. A rejected gap in the analysis is defined as the largest headway between two consecutive POV that is not used to perform a turning maneuver by an SV that can be reasonably assumed to be ready to turn.

While a sample of 109 left-turns was collected from the two-day survey of the Hearst and Shattuck intersection, there are only 28 observations for accepted gaps. Of the several reasons for this, the primary one is that the observations for accepted gaps that were longer than a predetermined value (say 12 seconds) were eliminated, since including those observations would erroneously increase the mean value of accepted gap.

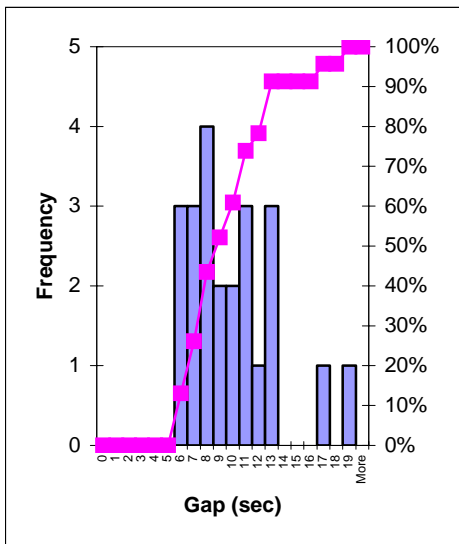

Figure 2.21 Accepted Gaps Histogram

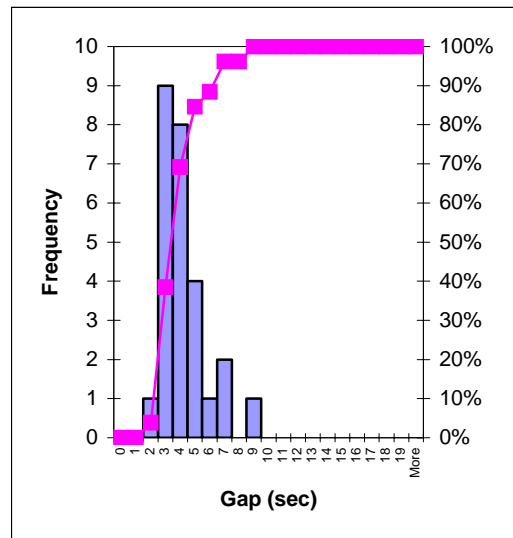

Figure 2.22 Rejected Gaps Histogram

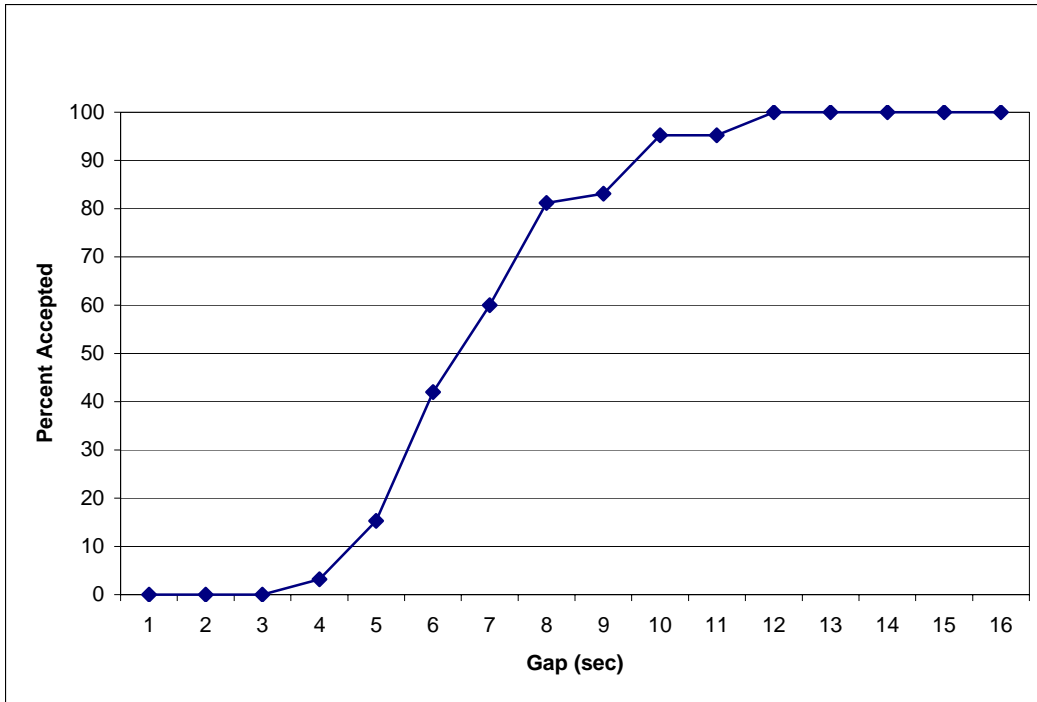

Figure 2.23 Percent Gap Acceptance for each Gap (Running Ave, 3 Adjacent Secs)

The histograms in Figures 2.21 and 2.22 display the percentage of gaps of various sizes that were accepted or rejected. The trend line representing cumulative percentage is an increasing curve for both histograms. From the histogram on rejected gaps it is evident that the percentage of rejections decreases as the size of the gap increases, although the reverse trend, in spite of being intuitive, is not evident from the histogram on accepted gaps. As a general observation, all gaps less than 3 seconds were rejected and all above 12 seconds were accepted. In between, the gap acceptance behavior varied, depending on the nature of the driver, showing a marked increasing trend with increase in the size of the gap.

Table 2-2 Gaps accepted under different situations

All Gaps	# of samples	28
	Mean	8.715536
	Std	3.498963
Pedestrians	# of samples	8
	Mean	11.35425
	Std	4.360415

On the fly	# of samples	1
	Mean	9.134
	Std	-
From queue	# of samples	2
	Mean	7.0165
	Std	3.936463
Yellow or Red	# of samples	0
	Mean	-
	Std	-
Remaining Observations	# of samples	17
	Mean	7.649059
	Std	2.512212

From Table 2.2, it may be concluded that the gaps accepted are the largest for the situation when a pedestrian is present in the destination crosswalk. For the other three situations, namely on the fly, from queue and yellow or red, the number of observations are too small to reach a valid conclusion.

2.12 Turning Time, Gap Acceptance and Buffer

From the difference in the mean value of turning time (3.3 seconds) and the mean value of accepted gap (8.71 seconds), it may be inferred that the entire gap is not always taken up by turning time. The time component of gap, located before and after the event of the turn, is called the ‘buffer’ for the purpose of this study. These two components of gap, namely buffer and turning time, are illustrated in Figure 2.24, which illustrates the 28 observations made for accepted gap.

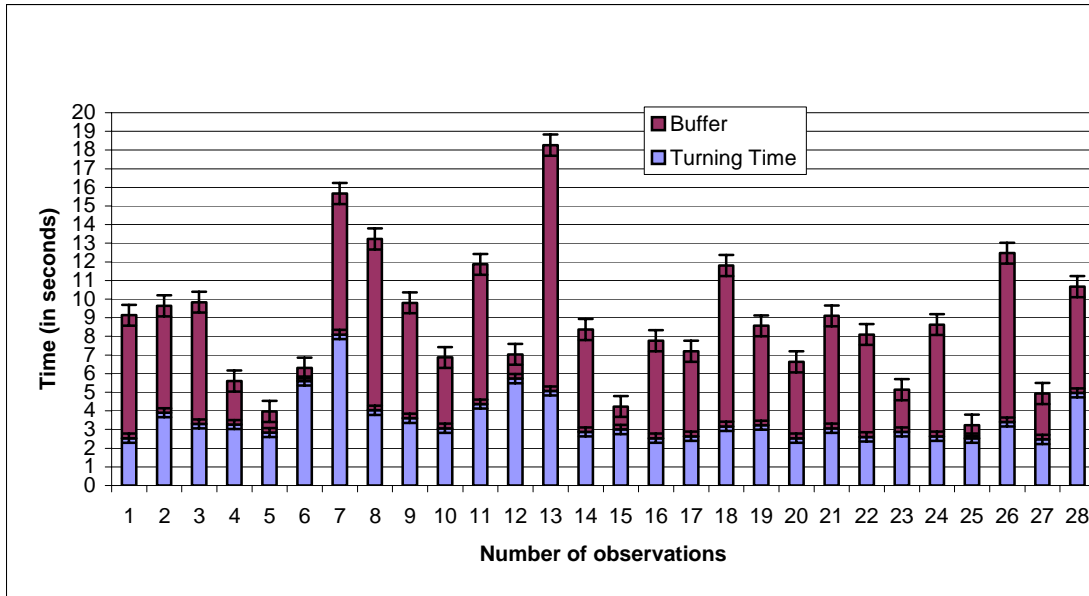

Figure 2.24 Components of Accepted Gap

The mean value of the buffer was calculated to be 5.14 seconds and the standard deviation was 2.98 seconds.

In Figures 2.25 and 2.26, turning time and buffer are plotted against accepted gap for all observations, and for observations eliminating those for which there were pedestrians in the destination crosswalk, respectively. From the trend lines it may be seen that turning time remains fairly constant with the change in the value of the accepted gap. The change in the value of the accepted gap is reflected in the change in the value of the buffer.

Figure 2.25 Turning Time and Buffer vs. Accepted Gap (all observations)

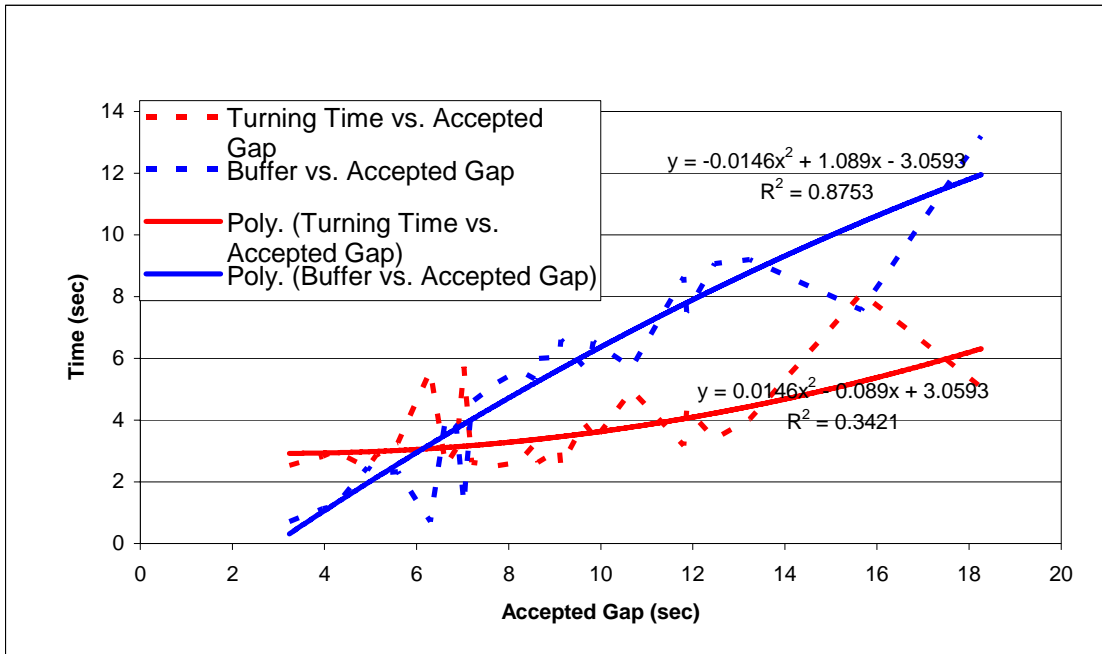
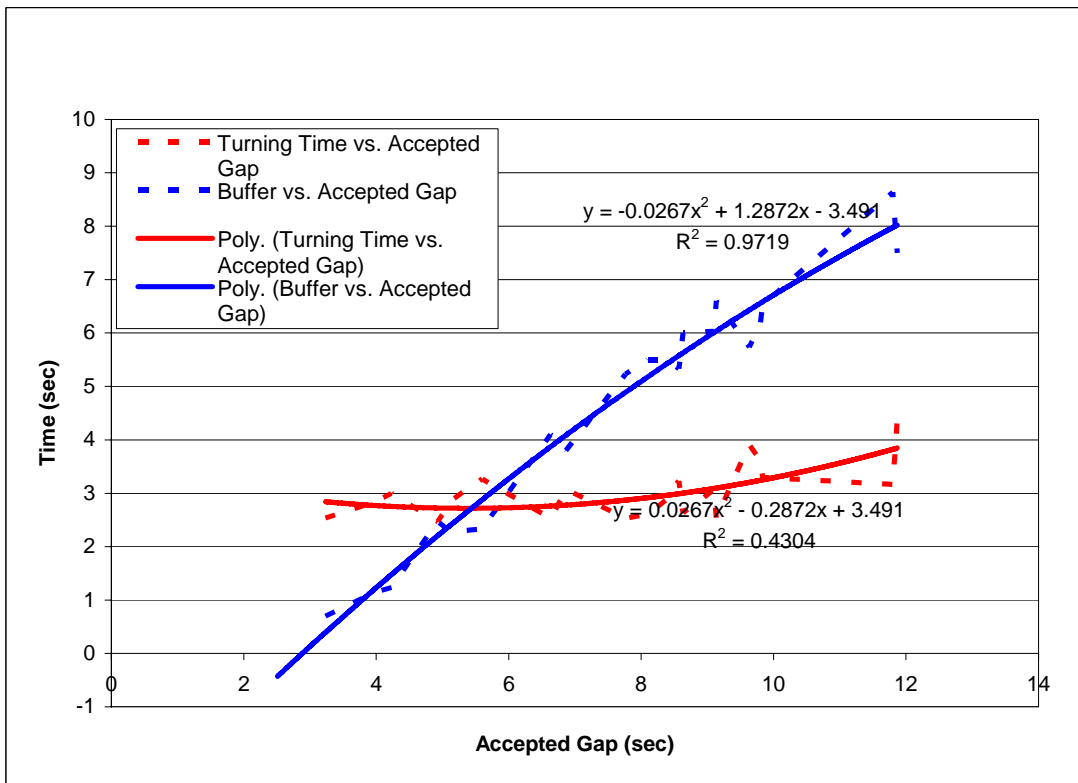

Figure 2.26 Turning Time & Buffer vs. Accepted Gap (minus pedestrian in destination crosswalk)



It may be observed that for a given value of the accepted gap, a rise in the value of turning time above the trend line is marked by an equivalent drop in the value of the buffer below the trend line. Turning time and buffer being components of the accepted gap serves as an explanation of this phenomenon. By comparing Figures 2.25 and 2.26, it may be inferred that these variations about the trend line are marked for those observations in which pedestrians are present in the destination crosswalk.

2.13 Further Evaluation

The data analysis described here represents the operation of one type of intersection under reasonably normal conditions, but cannot represent the operations of all intersections. Under the IDS project, to complete the IDS warning system design, it is therefore necessary to repeat the data collection at a broader sample of intersections and under a variety of conditions in order to develop a more general characterization of turning behaviors that can be used to support development of widely applicable warning algorithms. The additional intersection designs that are being considered for evaluation include:

- signalized, two lanes of POV traffic, but without left turn pocket (putting more social pressure on the driver to accept smaller gaps)
- unsignalized, one lane of POV traffic, no left turn pocket
- unsignalized, two lanes of POV traffic, with left turn pocket.

The design of the warning system also needs to be founded on information about the influences on turning behavior of a variety of operational conditions at the intersection, such as:

- density of pedestrians in crosswalks
- prevailing speed distribution of approaching POV traffic
- density of approaching traffic
- local norms of driving aggressiveness
- visibility (road geometry, weather and lighting conditions)
- road surface conditions.

Data collection needs to be conducted under the full range of variation of these conditions in order to determine the strength and nature of their influences on turning behavior. In that way, we can determine the extent to which the warning criteria and timing should be adjusted based on these conditions. Special attention needs to be given to the situations in which there is pedestrian presence in the destination crosswalk, since the preliminary analysis shows that it could affect turning characteristics significantly.

We provide quantitative characterizations of intersection turning behavior, which can be used directly to select the timing of the alerts to be given to the turning drivers, and also to evaluate the likely effects of the deployment of the IDS alert system. The alerts are being evaluated in a series of human factors experiments using an instrumented SV and test intersection, to determine how representative older and younger drivers react to the alert under different conditions. The results of those experiments will be applied, together with the observation data described here, to estimate the effectiveness of the alerts under the range of intersection designs and operating conditions that were observed.

2.14 Conclusion

In this report, an observation study at an intersection in an urban environment is presented. In this pilot study, experimental apparatus were used to monitor the movements of traffic streams with supplementary video recordings. The results from these observation studies are used to support the developments of Intersection Decision Support solutions.

The traffic data provides a sampling of vehicle movements at a signal-controlled intersection. By associating the traffic signal phase with the traffic movements, radar data was distilled to yield certain patterns during the transition of signal phase. An analysis of traffic data then allows the assessment of vehicle maneuvers and decision-making zones in the vicinity of the intersection. A further investigation also indicates how particular conflict scenarios, such as LTAP-OD, can be identified. Furthermore, data analysis techniques were developed to assess potential conflicts and hazards. For example, T2I was used as an indicator of the threat presented by opposing traffic. Collectively, the methodology developed from the pilot study proved to be a powerful tool for IDS and deserves expanded studies.

From the video data, the variation of turning times under different situations was studied as well as the characteristics of the gaps accepted and rejected under various situations. These analysis provide important insight for possible use in the warning system design.

For more comprehensive observations or for specific parameters that are of interest, the experimental setup for these field studies can be further improved to expand the capabilities of data acquisition, such as monitoring of vehicle movements in multiple directions. The observation and the extraction of critical parameters can be complicated by the presence of bicycles or pedestrians, as expected in an urban environment. In addition to the gathering of statistical data to support the development of IDS solutions, field observation studies will also be valuable in evaluating the effectiveness of countermeasures during implementation. These remain topics of future efforts.

2.15 Acknowledgements

We wish to express gratitude for the generous assistance from the City of Berkeley, California, especially Charles Deleuw and John Harris of the Public Work Department. We are also indebted to the support provided by our colleagues, Ashkan Sharafsaleh, James Misener, Steven Shladover, David Marco, David Nelson, Thang Lian, Bart Duncil, Aleksandr Zabyszny, Susan Dickey, and Paul Kretz, who generously provided their assistance in the execution of the field observation task.

This work was performed as part of the Intersection Decision Support project of the IVI Infrastructure Consortium by the California PATH Program of the University of California, in cooperation with the State of California, Business, Transportation and Housing Agency, Department of Transportation and the Federal Highway Administration. The contents of this report reflect the views of the authors who are responsible for the facts and the accuracy of the data presented herein. The contents do not necessarily reflect the official views or policies of the associated organizations. This report does not constitute a standard, specification, or regulation.

2.16 References

1. Ferlis, R.A., “*Analysis of an Infrastructure Collision Avoidance Concept for Straight Crossing Path Crashes at Signalized Intersections*,” Annual Meeting of the Transportation Research Board: Washington, D.C., January 2001.
2. Chovan, J.D., et al., “*Examination of Intersection, Left Turn Across Path Crashes and Potential IVHS Countermeasures*,” National Highway Traffic Safety Administration, Washington, D.C., DOT-HS-808-164, 1994.
3. Wang, J.-S., R. Knipling, “*Intersection Crossing Path Crashes: Problem Size Assessment and Statistical Description*,” National Highway Traffic Safety Administration: Washington, D.C., DOT-HS-808-190, 1994.
4. Misener, J.A., Ragland, D., Wang X.Q., Cohn, T.E., “*Toward a Smarter, Safer Intersection: Application of Intelligent Countermeasures to the Intersection Crash Problem*,” ITSA World Congress, Madrid, Spain, November 2003.
5. Woll, J.D., “*Monopulse Doppler Radar for Vehicle Applications*,” M+RF97 Microwave and Communications Technologies Conference Proceedings, London, United Kindom, pp.234-238, Oct. 1997.
6. Skolnik, M., Radar Handbook, 2nd ed., Sec. 18.8, McGraw-Hill, Inc., 1990.
7. Wang, X., Chan, C-Y, Misener, J., Shladover, S., Zhang, W-B, “*Coriolis Effect and Body-Object Effect: Limiting Factors in the Use of Remote Sensors in Ground Traffic*,” Annual Meeting of the Transportation Research Board: Washington, D.C., January 2004.

3 INTERSECTION OBSERVATION REPORT—RADAR AND VIDEO

3.1 Introduction

As stated earlier, the data collection in support of the IDS project fell generally into two categories: roadside observations and instrumented vehicle studies. This section of the report focuses on the roadside observations of driver behavior using both video and radar as observation tools. This report summarizes the analyses of both radar (Section 3.2) and video (Section 3.3) data gathered at five different intersections in the San Francisco Bay Area from October 2, 2003 to October 14, 2004 and (ii) develops implications for IDS systems for preventing LTAP-OD collision.

A total of about 12-14 hours of radar and video observations were completed at each of these five intersections. The analyses focused on:

- i) Distribution of gap availability;
- ii) Probability of gap acceptance by length of gap (“gap acceptance curve”);
- iii) Distribution of turning times.

The five intersections varied by configuration, traffic volume, general vehicle speeds, collision history, and other characteristics. The five intersections are:

- i) Hearst and Shattuck, an intersection in the downtown area of Berkeley. Both streets have two lanes of mainline traffic and left-turn pockets in both directions. This intersection is characterized by fairly heavy pedestrian traffic, which allowed us to observe the impact of pedestrians on SV movement.
- ii) Alameda/Marin, located in the north area of Berkeley, California. Both streets have two lanes of mainline traffic in each direction and no left-turn pockets. The approach observed at this intersection had a high percentage of left-turning traffic against a low volume of

oncoming traffic with the highest number of LTAP-OD collisions among all approaches observed.

- iii) An intersection defined by an entrance to a shopping plaza parking lot from San Pablo Avenue in the City of Pinole. San Pablo Avenue is a major thoroughfare with two lanes of mainline traffic in each direction with a single-lane left-turn pocket for vehicles entering the parking lot. The intersection is un-signalized with a stop sign for vehicles leaving the parking lot.
- iv) El Camino Real/Chapin Avenue (northeast-southwest) in the southeast area of Burlingame. Both streets have two lanes of mainline traffic in both directions, and there are no left-turn pockets at El Camino Real. The approach observed is characterized by relatively heavy high-speed traffic.
- v) Brannan/Fifth Street in the downtown area of San Francisco, California. Both streets have two lanes of mainline traffic in each direction and no left-turn pockets. This intersection is in a highly urban location with a high proportion of oncoming vehicles making right turns, partially impeding SV left turns.

The detailed description of the radar observations and video observations are given in the following two subsections (3.2 and 3.3). The radar data is mainly relevant to the POV movement and approach to the intersection, while the video data focuses mainly on SV movement, including turning time and gap acceptance patterns. An overall introduction to the data collection efforts (roadside and instrumented vehicle) is given above (Section 3.1) and will not be repeated here. Likewise, an overall summary of conclusions and implications for the data collection efforts is given in Section 3.1, and will not be repeated in this section.

3.2 Radar Observation Report

3.2.1 Introduction

Task B2, expanded field observation, is an extension of Task B1. The pilot efforts carried out in B1 allow us an opportunity to experiment with a methodology of collecting traffic data at intersections in our pursuit of acquiring traffic patterns and driver behavior information, towards the design of IDS. In order to be flexible in locations of observations, we have instrumented a mobile data collection station in the back of a van and supplemented it with video camera recordings, as depicted in Figure 3.1. Some further explanations of the setup are given in other sections below.



3.1 Video Recording of Hearst and Shattuck

In earlier publications, a methodology was reported for the use of field observations to monitor traffic patterns and to extract parameters that represent driver behaviors in particular situations of interest. Field data was utilized to monitor traffic patterns at signalized intersections.^{2,3} Quantitative characterizations of intersection turning behavior, which can be used directly to select the timing of the alerts to be given to the turning drivers, were explained in another publication.⁴ Techniques were suggested for processing and utilizing field observation data to estimate time-gap acceptance by drivers.⁵ Another effort was made to evaluate the effect of pedestrian traffic and its impact on left-turn vehicles.⁶ The relevant technical issues in the design of alerts for IDS systems were elaborated and simulation tools were developed for the evaluation of various traffic scenarios.⁷ In another paper, the discussion was extended to the interpretation of risk-taking behaviors exhibited by the drivers from the collected field data.⁸

The basic methodology of data collection and analysis based on field observations has been documented in the earlier B1 report. In this report, we present a wider scope of field observation and more in-depth analysis. Specifically, we provide comparative characterization of traffic at several observation sites. Furthermore, we described an approach for deriving driver gap acceptance parameters in left-turn across-path maneuvers. Certain sections of this report have also been reported in technical publications during the last year. In this report, we assemble a summary of the significant highlights and outcomes from the studies.

3.2.2 Motivation and Method of Approach

One unique aspect of providing advisory signals to drivers, such as those proposed in IDS applications, is the diverse spectrum of driver perception and reaction to the alert or warning signal, which in turn decides the effectiveness of the safety systems. It is critical that the advisory signal is generated in a timely fashion and communicated to the drivers with the least occurrences of false or nuisance alarms. However, it is impossible to satisfy this requirement for each individual driver, who is likely to perceive the same traffic condition in a variety of manners and take risks according to his/her own judgment. An advisory warning at the same objective risk level, based on traffic conditions, can only be satisfactory for most drivers. This is particularly true if the suggested warning is presented in the form of a driver-infrastructure interface (DII) such as a dynamically activated sign at the subject intersection. For vehicle-based

solutions with a driver-vehicle interface (DVI), such as visual or auditory signals, it will be feasible to implement adaptive sensitivity to accommodate individual preferences of drivers.

Given the needs and constraints in design and implementation, it becomes apparent that the observation of driver behaviors, either under naturalistic driving conditions or in controlled experiments, will be helpful in determining the proper threshold for warning. The contents of this report are focused on field observations in real-world traffic settings to extract relevant information. An attempt is made to quantify the driver behaviors and traffic parameters that can help define driver behaviors.

Specifically, for the understanding of drivers' behaviors in potentially conflicting situations, the field observations may provide some answers to the following questions:

What are the relative states (position, speed, orientation, etc.) of the subject vehicle (SV) and other vehicles (OV) in a potential crossing-path conflict when the SV driver decides to proceed forward? Often times, most relevant to the decision of the SV driver is the state of the principal other vehicle (POV), which is the closest or most relevant other vehicle in time or distance.

What do the patterns defined by SV and POV states reveal about driver decisions?

What variables can be used to identify the potential conflicts for the implementation of IDS systems?

In the following section, several sets of real-world traffic data are used to illustrate how field observation is conducted and how vehicle maneuvers in crossing-path traffic situations are analyzed to reveal the patterns of driver behaviors. The descriptions of field studies are first described in Section 3.3, and data analysis is presented in Section 3.4. Then a method of deriving driver time-gap acceptance is explained in Section 3.5.

3.2.3 Field Observation—Data Collection

It is important to understand driver behaviors under a wide spectrum of traffic conditions and intersection characteristics; therefore the selection of field observation sites is made to allow as much diversity in relevant factors as possible among the locations. The potential relevant attributes include neighborhood setting (urban, suburban, rural), intersection features (traffic control, signal cycle, geometric layout), and traffic conditions (traffic volume, prevailing speed,

pedestrian presence, etc.). For the work conducted in the IDS project in the last two years, data collection was carried out at the following intersections:

Shattuck and Hearst (the city of Berkeley)

Marin and Alameda (Berkeley)

Derby and Martin Luther King (Berkeley)

Entrance into Del Monte Plaza from San Pablo Ave (Pinole)

Chapin and El Camino Real (Burlingame)

5th and Brannan (San Francisco)

The data collection at Shattuck and Hearst was conducted on three different dates with over 6 hours of real-time data overall, while 2-3 hours of data was collected at each of the other sites. Among the aforementioned intersections, the sampling at Derby/Martin Luther King in Berkeley provided only a small number (few than 15) of left-turn scenarios. The samples at Marin/Alameda on the observation date, on the other hand, were found to possess a low volume of POV traffic. These two sets of data may not be representative of driver behaviors in comparable situations at respective locations. Therefore, the data at Derby/Martin Luther King and Marin/Alameda will not be presented for comparison with the other sites in this report. The overall observation study, however, does encompass a significant number of left-turn maneuvers from several locations and they offer a statistically meaningful representation, as can be seen in the following discussions. More importantly, the analysis of these left-turn scenarios reveals patterns that allow us to hypothesize a correlation of driver behaviors and intersection attributes and further offers some guidelines in the pursuit of future fieldwork.

Table 3-1 Intersection and Traffic Characteristics of Field Observation Sites

Observation Site ID	A	B	C	D
Location	Hearst /Shattuck, Berkeley	Chapin /El Camino Real, Burlingame	5 th Street /Brannan, San Francisco	San Pablo Ave, Pinole
Urban/ Suburban	U	S	U	S
Traffic Control	Traffic Signal	Traffic Signal	Traffic Signal	None
Pedestrian Traffic Presence	Frequent	Few	Few	Few
Number of POV	2	2	2	2

Mainline Lanes				
Left-Turn Pocket For SV	Yes	No	No	Yes
Signal Cycle Length (seconds)	75	80	60	N/A
Green Phase Length (seconds)	34.5	55-65 (variable)	20	N/A
Amber Phase (seconds)	3.3	3.5	3.5	N/A
All-Red Phase (seconds)	2.0	0.5	0.5	N/A
POV Traffic Volume (POV vehicles per minute)	Medium, 10+ (at time of data collection)	High, 20+ (at time of data collection)	Medium, 10+ (at time of data collection)	Medium, ~ 10 (at time of data collection)
Prevalent POV Speed	9-14 m/sec (20-30 mph)	16-20 m/sec (35-45 mph)	9-14 m/sec (20-30 mph)	16-20 m/sec (35-45 mph)
Total Numbers of Observed LTAP-OD SV	232	226	112	81
LTAP-OD SV Traffic Volume (Average SV per hour)	30+	84+	42+	30+

Figure 3.2 shows the data acquisition setup at Site A, an urban intersection in the downtown area of Berkeley, California. As depicted, this intersection has two lanes of traffic in the mainline traffic direction (Shattuck Ave.) and a left-turn pocket for SV waiting to make left turns. The intersection is controlled by signal lights, which have a signal cycle of 75 seconds at the time of observation (late morning to early afternoon). The hours of observation at Site A were characterized by a medium level of traffic with an average speed of 11 m/sec (25 mph) and ample opportunities for gaps between vehicles that enables SV to complete its desired left-turn maneuver.

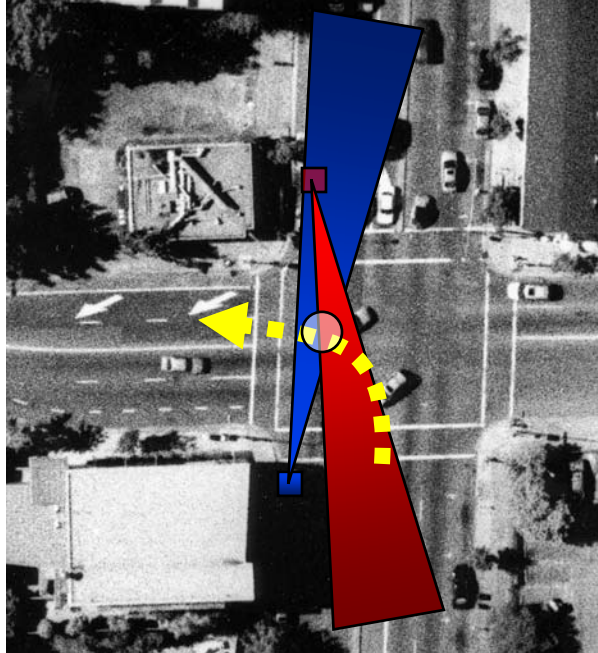

Figure 3.2 A Depiction of Data Collection Setup at Shattuck and Hearst in Berkeley

A curve is shown in Figure 3.2 to represent the trajectory of a left-turn SV. A triangular area is used to show the coverage area of a radar sensor with its placement at the tip of the triangle. A circle is placed within the triangle as the crossing point of the left-turn trajectory. Similar icons are also depicted in Figures 3.3-3.5.

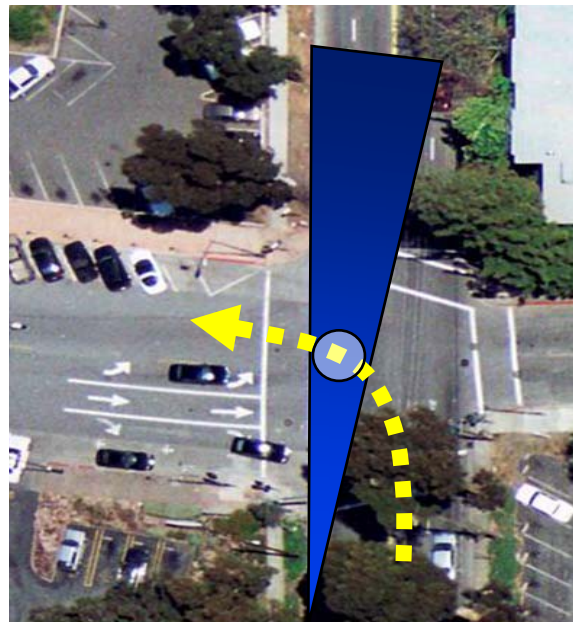

Figure 3.3 Data Collection Setup at Chapin and El Camino Real in Burlingame

Figure 3.3 shows the configuration at Site B, a suburban area in the city of Burlingame, California. The main street, El Camino Real, is a major corridor with a consistently high volume of traffic at moderate to high speeds (16 to 20 m/sec or 35-45 mph) at almost all hours. There are frequent occurrences of observed left-turning SV at the intersection of El Camino Real with Chapin, where several commercial properties are located. Due to the high traffic volume, SV drivers often are forced to wait till the end of the green phase in the signal cycle. The signal cycle is adjustable to allocate more time for the traffic on El Camino Real, with the green phase occupying 55-65 seconds out of the total 80 seconds in a cycle. At this location, due to the geometric constraints, there are no parking lanes or left-turn pockets. The intersection has a trapezoidal shape because of the unequal widths of Chapin Ave. on the two sides of El Camino Real.

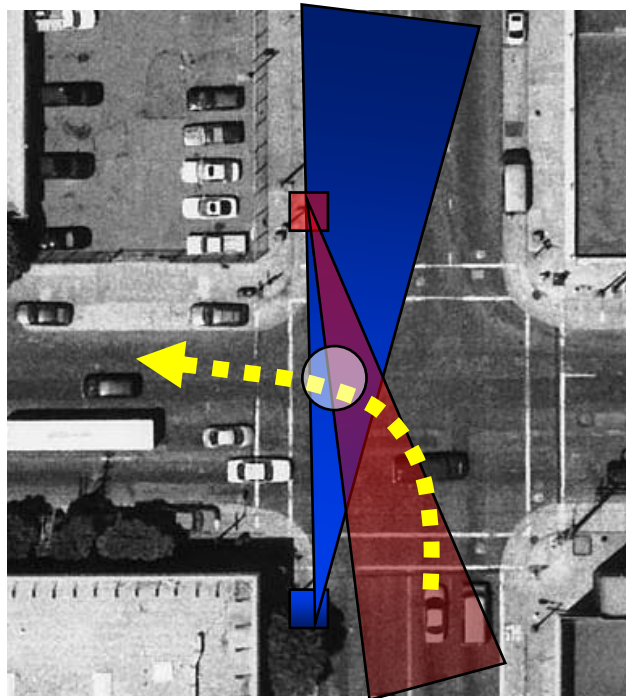

Figure 3.4 Data Collection Setup at 5th and Brannan in San Francisco

Figure 3.4 shows a similar setup for Site C, an intersection in San Francisco in an industrial neighborhood. The left-turn SV on northbound 5th Street turns into westbound Brannan, which is a major street with a considerably high volume of traffic. The green phase in the 5th Street

direction only occupies 20 out of the total 60 seconds of the signal cycle. There are parking lanes on all directions of travel, but no left-turn pockets.

Figure 3.5 A Depiction of Data Collection Setup in Pinole

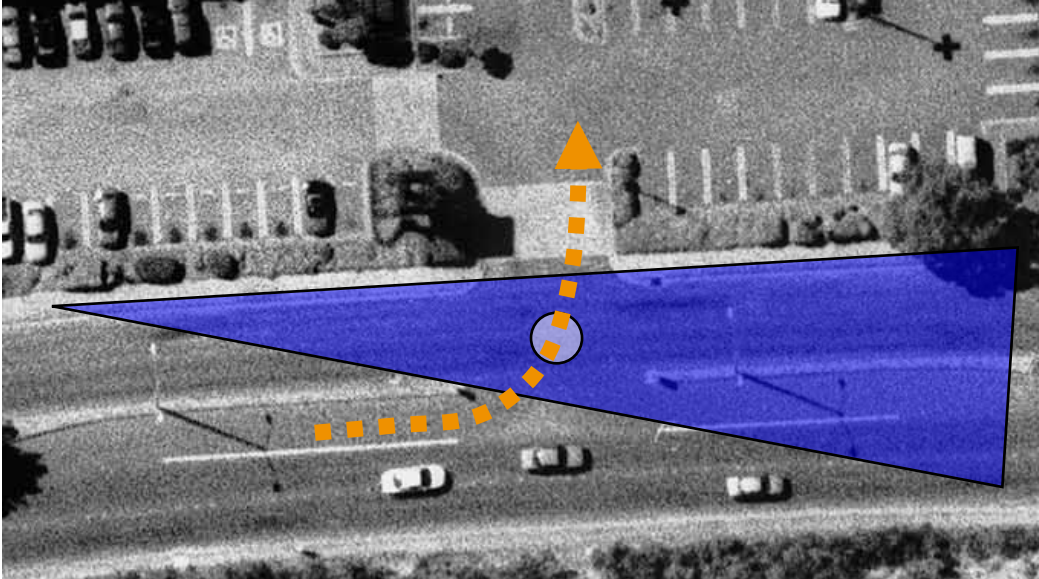

Figure 3.5 depicts the setting for LTAP-OD scenarios at a non-signalized location in the city of Pinole, where vehicles entering and exiting from a shopping center face opposing traffic approaching from the right side of the picture. Traffic-cruising speeds on the mainline of traffic, a major state route (San Pablo Avenue), have an average of 16-20 m/sec (35-45 mph). For LTAP-OD SV, the view of a driver facing the POV direction is partially obstructed due to a slight curve of the roadway and the trees planted on the median island.

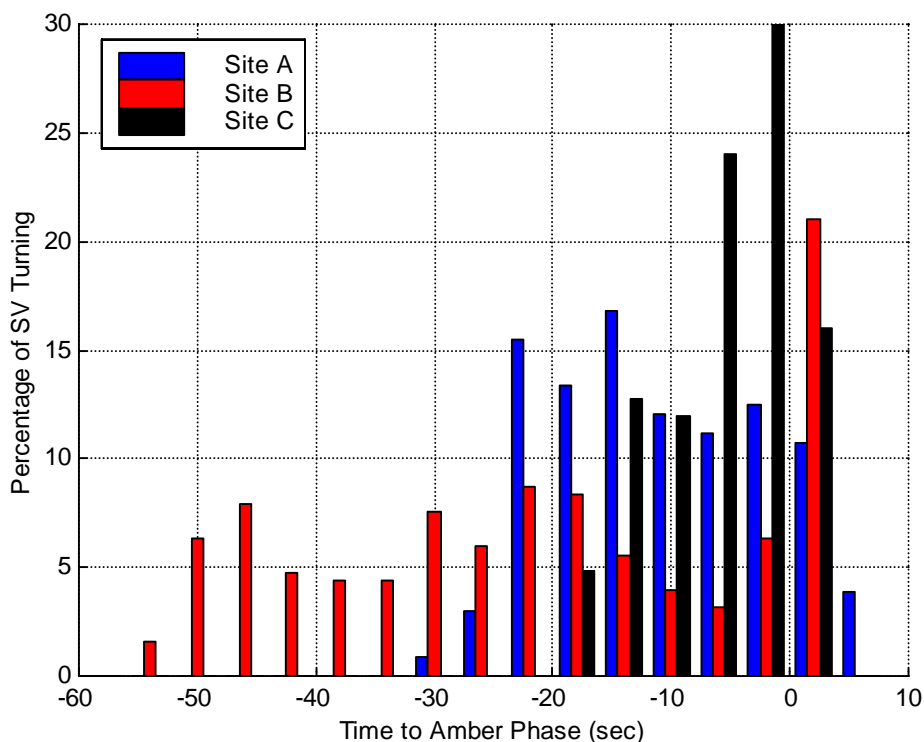

Figure 3.6 SV Turning Time in Signal Cycle at Three Observation Sites

Drivers anticipate and react to signal transitions at signalized intersections. As a result, the timing of SV turning within the signal cycle may have an effect on the behaviors of drivers. Figure 3.6 shows a comparison of turning time distribution among the three signalized intersections in Table 3.1. The numbers for each site are normalized to be shown as a percentage of the total numbers of SV. Note that the signal cycle lengths of the three sites are different. The green time is 34 seconds for Site A, 55-65 seconds for Site B, and 20 seconds for C. The graph shows the time of SV turning relative to the beginning of the amber phase. A negative reading on the horizontal axis means the turn occurs in green and a positive reading implies turning in amber or early red phases. The values in the vertical axis are the percentage of SV turning at the corresponding time at the respective sites.

The distribution of Site A (Berkeley) was relatively even across a 20-plus second window within the 34 seconds of green, with a relatively small portion of turns occurring in the amber and early red phases. Site B (Burlingame), on the other hand, sees a significant level of late turns when compared to a low and flat distribution across the 60-second green phase. The green phase at Site

C (San Francisco) is only 20 seconds long, thus forcing a very high percentage of late turns in the vicinity of the signal transition from green to amber. As will be seen in the discussion in the following section, the variations in turning time within the signal cycle do have an impact on the risk levels assumed by SV drivers.

The field observation reported in this paper was conducted as an initial yet critical part of work in the overall scheme of IDS work. The task was set out to utilize a limited amount of resources to explore data collection under a variety of traffic conditions at a few candidate intersections. Instead of a complete instrumentation setup at the selected sites with extensive and permanent equipment, the intention was to utilize a minimum amount of equipment on a mobile platform that can be deployed at desired locations flexibly. Given these constraints, it should be noted that there were noticeable limitations during the course of data collection, including the following: The sensor placement strategy was not thoroughly explored to choose an optimal location or to assemble a fused set of multiple sensors, therefore the setup did not allow a complete tracking of all targets. For example, some targets were blocked partially by other vehicles or objects in the roadway, and therefore might disappear from radar in some portions of their trajectories. Since the radar sensor used for vehicle detection and tracking is based on the Doppler Effect, stationary targets would disappear shortly after they arrived at the intersection and stopped for signals or other reasons.

Radar detection, even with the reasonably high performance specifications offered by the chosen product, does not necessarily always generate accurate measurements, since radar waves can reflect off various parts of a vehicle, thus only providing approximate values of distance and speed.

Even with the limitations described above, it was discovered from further analysis of the data that the simple data-acquisition setup turned out to yield reasonably satisfactory results for the purpose of data evaluation. This is mainly due to the fact that the closest moving POV is most critical for SV driver decisions and these POV in almost all cases were successfully detected and tracked by the radar. The analysis of radar data was also supported by video recording, which

provided useful supplementary information when radar data became ambiguous or erroneous in certain situations.

3.2.4 Interpretation of Driver Behaviors Based on Field Observation

In order to utilize the collected data, the traffic scenarios of interest, such as the LTAP-OD situations shown in Figures 3.2-3.5, are first identified for review. This is accomplished with an automatic scan of targets detected by radar and supplementary review of video data. Based on these identified samples, further analysis can be conducted to understand the interaction of SV and POV movements, from which SV driver risk-taking behaviors can be derived.

From the basic understanding and preliminary observations of driver behaviors, it can be assumed that SV driver decisions to initiate a left turn are generally based on a “gap (between vehicles)” or “lag (to arrive at intersections)” in the opposing traffic. In other words, drivers typically judge how far the oncoming vehicles are from the intersection or from the currently passing vehicles and how quickly they will arrive at the intersection to decide whether it is safe to initiate a maneuver. Previous research also showed some evidence that such driver decisions can be a combination of time and distance gaps^{9 10}. This phenomenon appears to be confirmed in the field observation, as explained below.

In the following sections, the time to point of conflict (TTPOC) of oncoming traffic is used as a primary measured parameter for the reasons as follows:

TTPOC is defined to be the estimated arrival time of a vehicle by dividing the current distance to the point of conflict (DTPOC) of the target vehicle by its instantaneous speed.

By estimating time to conflict, distance and speed of target vehicles are both taken into account in threat assessment.

The movements of POV are synchronized and tied into the trajectories of SV by tracking trajectories of POV targets relative to the arrival time of each SV.

The approach time of SV and POV to the point of conflict (POC) conveniently offers a physical representation of a potential collision.

At later sections, a specific definition of time to conflict (TTC) will be used to represent the time differential of SV and POV arrival at the point of conflict. It should be noted that the terminology TTC used herein is different from the conventional use of TTC, which is usually chosen to denote the time to collision. TTC may be calculated, for instance, by dividing the space between two vehicles by the speed differential in a vehicle-following situation.

Indeed, as illustrated by data analysis and interpretations below, TTPOC and TTC represent critical parameters in modeling left-turning crossing-path conflicts. In addition, as an alternative measure, the distribution of POV-DTPOC at various sites is also utilized to help understand the difference in driver behaviors at various sites.

Implications for IDS

1. POV-TTPOC, time to point of conflict of the principal other vehicle, is a critical parameter in determining the threat presented by the POV and should be included in the warning algorithms, if not used as the only criterion, for deciding whether and when to issue an alert signal to the driver of the subject vehicle.
2. Since intersection geometries vary significantly from one site to another, the point of conflict is a better reference point in assessing the threat of arriving vehicles than the stop bar or crosswalk location of the intersection.

3.2.4.1 Characterization of Left-Turn Traffic Conditions by POV TTPOC and DTPOC

This section describes the use of field data to characterize the interaction between SV and POV traffic. To start, for each appearance of an SV, all other vehicles within the radar field of view are scanned and examined. If the target is a legitimate vehicle traveling within the opposite traffic lanes faced by the SV, then its TTPOC is calculated. The one target with the shortest TTPOC is designated as the POV. The arrival of SV at the point of conflict is identified by its moving across the POV trajectories, depicted by the circles in Figures 4.2-4.5. Relative to the arrival of SV at the point of conflict, all POV are monitored and tracked.

If the TTPOC of all POV is plotted versus the time relative to SV arrival, then the “closeness” or threat of POV traffic to a turning SV can be observed. Figure 3.7 shows a graph to indicate the relative timing of POV arrival versus SV arrival. The value of the horizontal axis shows the time relative to the instant when SV is crossing POC at time = 0. The negative-reading time window along the horizontal axis defines the period before SV arrival and the positive region represents the period after SV arrival. A time window of 6 seconds prior to time zero and 4 seconds after is shown. The values on the vertical axis indicate the instantaneous POV-TTPOC. Two color schemes are used for lane differentiation of target locations.

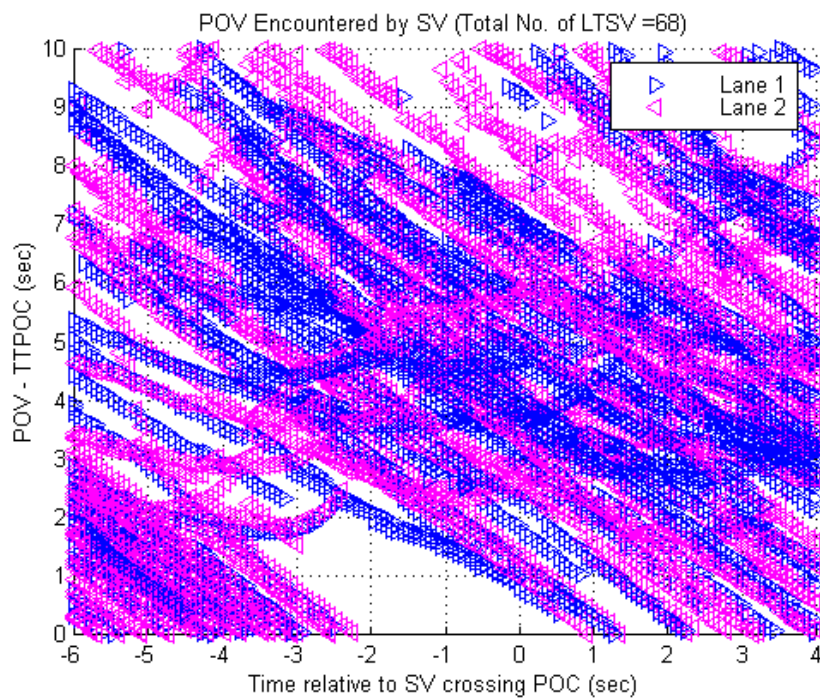

Figure 3.7 POV-TTPOC versus Time Relative to SV Crossing POC (Data 12/11/03)

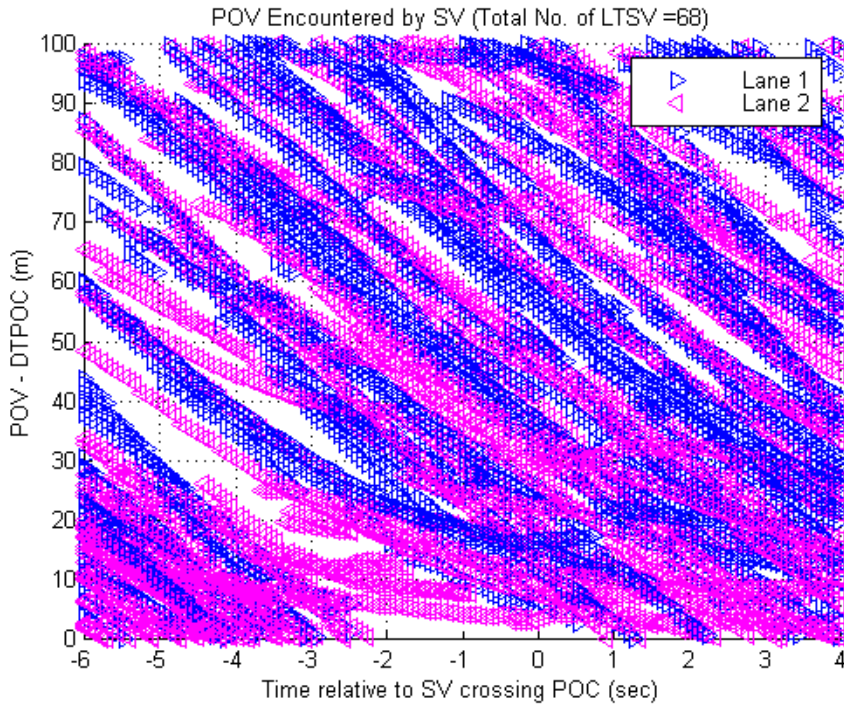

Figure 3.8 POV-DTPOC versus Time Relative to SV Crossing POC (Data 12/11/03)

Figure 3.7 is a composite chart generated from a two-hour data set from Site A. There are a total of 68 left-turning SV in this data set. Figure 3.8 is the corresponding chart with the POV distance to point of conflict (DTPOC) plotted in the same time window. A few notes should be made to explain the patterns shown in these two figures.

If a POV cruises toward the intersection, its TTPOC trajectory will be a straight line with a down slope of minus one in Figure 3.7 at constant speed.

If a POV slows down, the slope of its TTPOC trajectory will decrease (in absolute value) and transition to a curve with a positive slope, as seen in a few examples in Figure 3.7.

Some SV need to wait for a previous POV to move through the intersection before it makes its turn. These previous POV cross the point of conflict before SV arrival at time = 0. In Figure 3.7, these POV are shown to move through before SV arrival prior to $t = -2$. The corresponding trajectories of POV are also evident in Figure 3.8 as their DTPOC goes below zero before time zero.

The two-second period described above in (3) is sometimes called the leading buffer, which means the time elapsed between a previous passing POV and an SV crossing POC.

When there is a close encounter, the arrival times of SV and POV reaching POC are close to each other, as indicated by a few cases in Figure 4.7 with POV-TTPOC crossing near or below $\text{time} = +1$. The corresponding cases are also visible in Figure 8, where the DTPOC of POV comes within 10 meters before $\text{time} = +1$.

For a majority of cases, POV does not reach the point of conflict until at least two seconds after SV crosses POC.

The two-second period explained above in (6) is sometimes referred to as the trailing buffer. If a SV is turning aggressively in front of a fast approaching or close POV, the trailing buffer will be short. For conservative drivers, the trailing buffer may be long.

With finite values of leading and trailing buffers, it is noticeable from Figure 3.7 that a recognizable “time window” is existent just prior to and after SV crosses POC at $\text{time} = 0$. The window exists since there needs to be a physical gap in time and space for the SV to successfully maneuver its way between the passing and approaching POV.

It should be noted, however, that the buffer in time and space as shown in Figures 3.7 and 3.8 is defined by radar measurements. The POV-TTPOC is calculated with the front of the target vehicle arriving at POC, while the SV is detected when its side moves across the radar field of view. Thus, the indicated buffer time is offset by a time interval for the length of POV vehicle to move through POC.

Also noticeable in field data is the dynamic interaction between the SV and POV motions. This is reflected in some trajectories of POV when TTPOC or DTPOC deviates from their projected paths when a SV is present. The other primary factor that causes POV trajectories to change course is the transition of traffic signals, especially from green to amber or amber to red.

Implications for IDS

1. Identifiable patterns in traffic interactions and associated parameters are recognizable in field observations.
2. Field observations provide a valuable venue for estimating the leading and trailing buffers accepted or taken by the drivers of subject vehicles. The results derived from field data constitute a significant baseline for conducting further driving tests or human-factor studies.

3.2.4.2 Driver Behaviors under Different Traffic Conditions

At Site A, data collections were conducted on multiple days and a variation of traffic volume was noticed. An examination of multiple data sets reveals the effects of traffic conditions. In order to analyze the data comparatively, the distribution of POV-TTPOC was calculated and shown in Figure 3.9. The graph is generated from the same data set used in Figure 4.7 with 68 left-turning SV, but illustrated in a three-dimensional manner. The number of POV with the same TTPOC values within one-second division was counted, and the process was repeated for every second interval within the time window of $t = -6$ to $t = +4$ versus the SV arrival time. The POV counts are then normalized into percentage readings by the total number of SV and plotted versus the two horizontal axes of SV time to POC and POV-TTPOC.

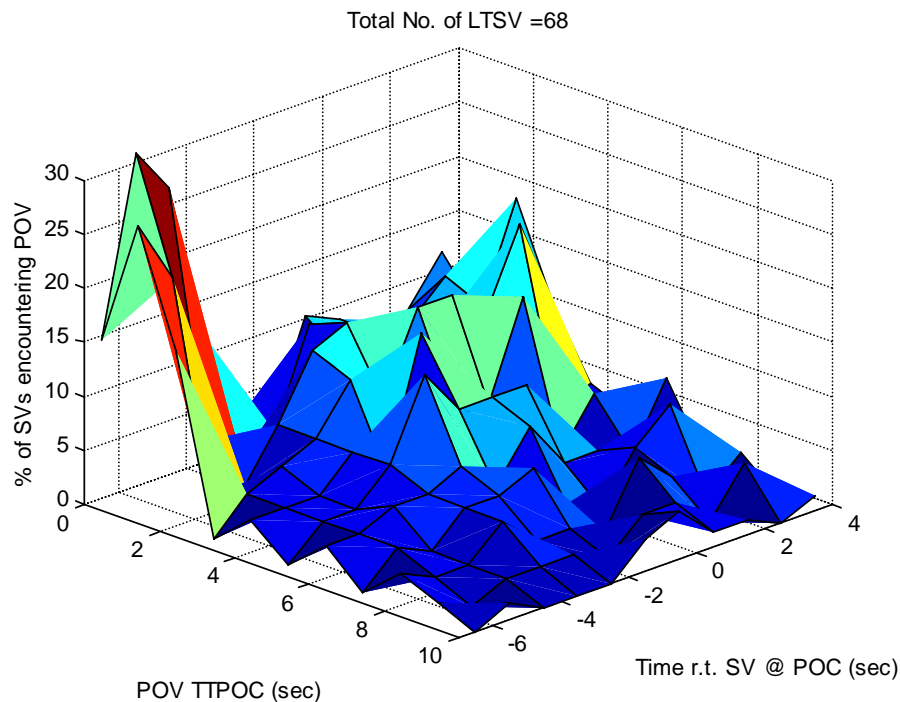

Figure 3.9 POV-TTPOC Distribution vs. Time Relative to SV Crossing POC (Data 12/11/03)

On the left-side corner of the distribution curve, a peak represents a batch of previous passing POV before SV turning. Adjacent to this peak is a “valley” or a “gap” in POV traffic, which is followed by another batch of arriving POV. The counting of POV numbers over time provides a perspective on their arrival distribution, in addition to the concept of a time gap in Figure 3.7.

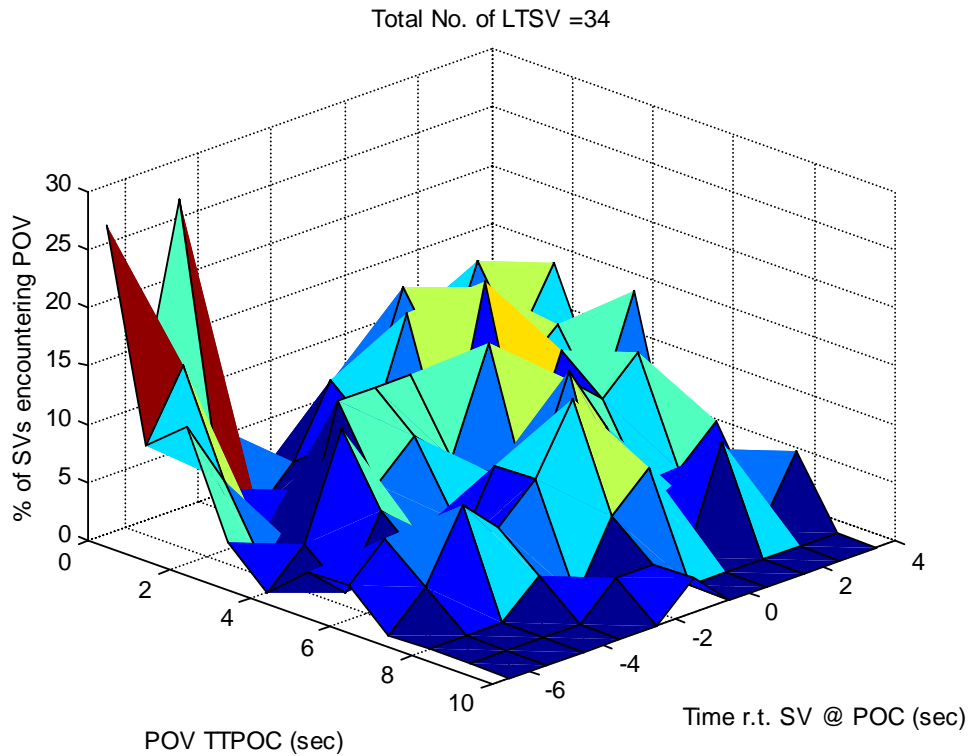

Figure 3.10 POV-TTPOC Distribution vs. Time Relative to SV Crossing POC (Data 10/02/03)

A similar chart for a different set of data was generated and shown in Figure 3.10. During this second observation, the volume of traffic was lower for both SV and POV. Only 34 SV were identified. Figure 3.10 also reveals a subtle but meaningful difference. Even though the shape is approximately the same, the gap in Figure 4.10 is wider and the overall distribution shows a lower overall percentage in the range of POV-TTPOC = 0 to 4 seconds and higher percentage in the range of POV-TTPOC = 4 to 8 seconds. In other words, the POV traffic shown in Figure 4.9 is closer and more threatening than those in Figure 3.10 as a whole.

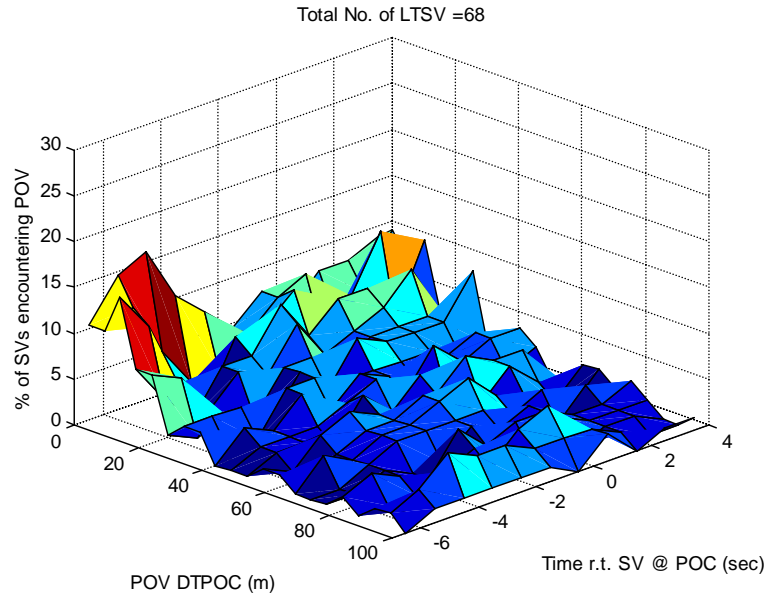

Figure 3.11 POV-DTPOC Distribution vs. Time Relative to SV Crossing POC (Data 12/11/03)

The distinction is also evident in the distribution of POV distance to POC (DTPOC). Figure 3.11 and 3.12 are the corresponding graphs of the two data sets from Figures 4.9 and 4.10. It can be noticed that the “space gap” in Figure 3.11 is partially filled and the distribution at the short range (0-20 meters) has a higher ratio, while the gap is clearly visible in Figure 3.12 for the second data set.

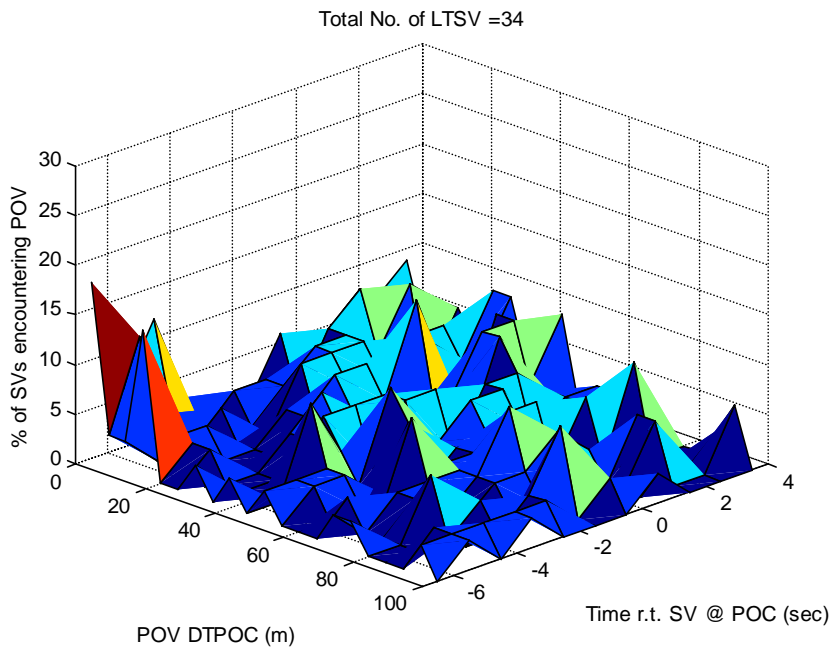

Figure 3.12 POV-DTPOC Distribution vs. Time Relative to SV Crossing POC (Data 10/02/03)

The distinction between the “time gap” and the “space gap” is due to the use of POV speed in the calculation of TTPOC. While the “time gap” is identifiable in Figure 3.9, the “space gap” in Figure 3.11 is less obvious for the same set of data. The POV vehicles in the “space gap” area of Figure 3.11 probably possess relatively low speeds even though they are close in distance.

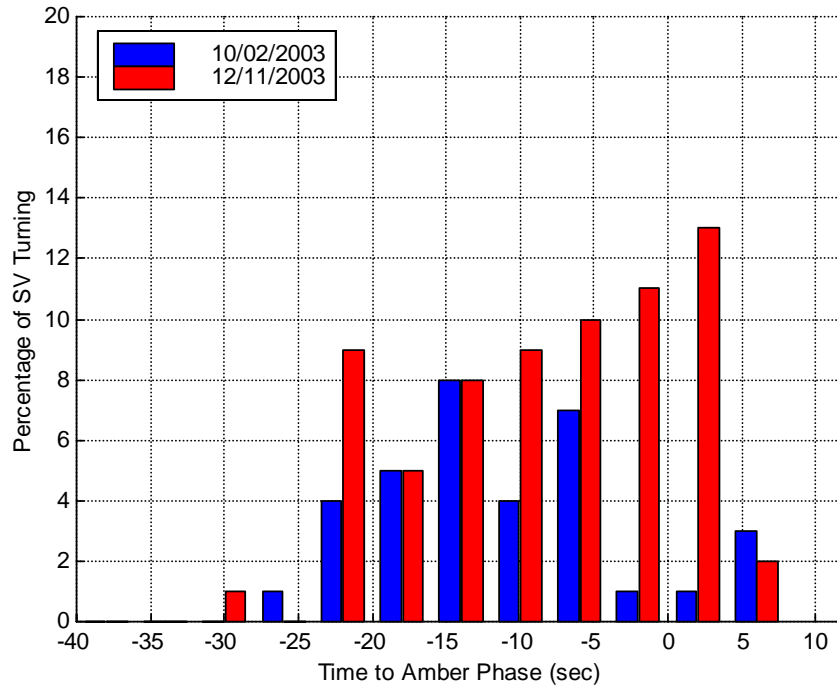

Figure 3.13 SV Turning Time in the Green Signal Phase (Two Data Sets at Site A)

One contributing factor in causing a shift in the distribution between the two data sets from Site A is the SV turning time within the signal cycle. Figure 3.13 shows the numbers of SV plotted versus their turning time in the signal cycle. The two sets of data are from the same observation site and have the same signal cycle length. It can be seen that there are a greater number of late turning SV in Data Set No. 1 (12/11/2003). In these late turning situations, there may be many POV approaching the intersection and slowing down for the amber and red signal phases. If an SV is turning in the face of these POV, then the POV will appear on Figures 3.9 and 3.11 within a shorter distance and/or with a lower TTPOC value. Conversely, it can be stated that drivers may be tempted to act more aggressively in late-turn situations to avoid waiting for another cycle. This also contributes to a higher ratio of more threatening POV.

3.2.4.3 Driver Behaviors at Different Intersections

Observation sites have been selected to allow variations in intersection and traffic attributes as explained in Section 2. The comparison of observation data and the interpreted driver behaviors at multiple sites are important for the consideration of IDS system design. Even though further extensive observation studies will be necessary to establish complete guidelines for selecting the threshold of warning criteria, an analysis of collected data from this preliminary study does offer valuable insight into the understanding of driver behaviors.

For Site A, data from 3 separate days of field observations are aggregated into one data set of 232 SV with the distribution of POV-TTPOC and POV-DTPOC shown in Figures 3.14 and 3.15. The graph shows similar shapes as depicted in Figures 4.9-4.12. The “gap” in TTPOC in Figure 3.14 is clearly visible while the distribution of DTPOC is biased toward the short range in Figure 3.15.

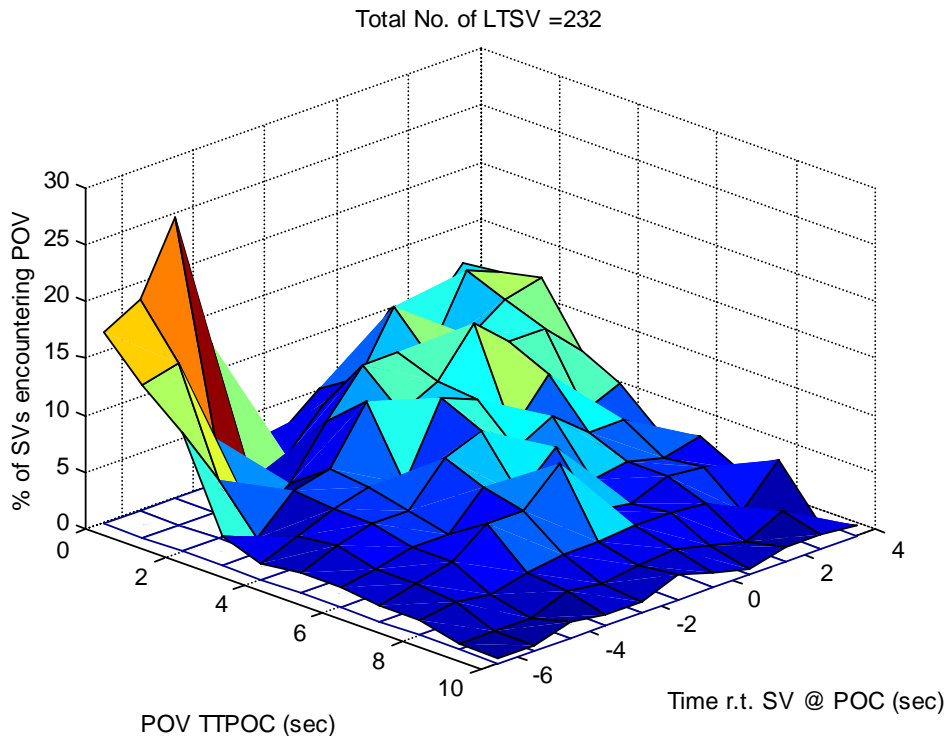

Figure 3.14 POV-TTPOC Distribution vs. Time Relative to SV Crossing POC (Site A)

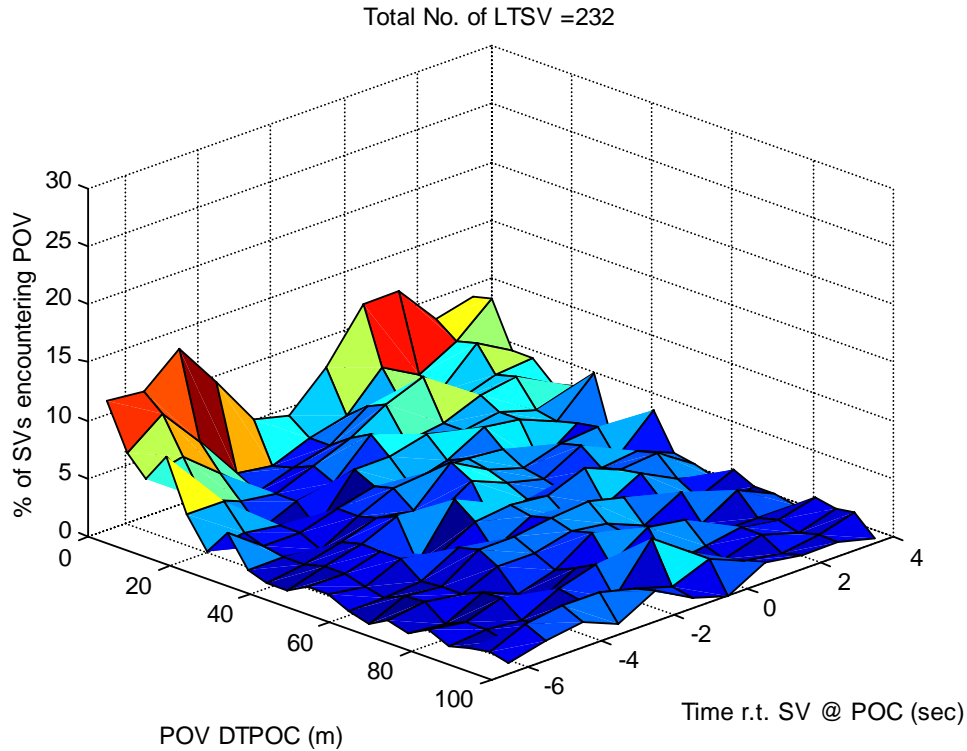

Figure 3.15 POV-DTPOC Distribution vs. Time Relative to SV Crossing POC (Site A)

Figures 3.16 and 3.17 are the graphs for Site B with a total of 226 SV cases. The two graphs, when compared to those of Site A, show a higher ratio of POV with lower TTPOC and DTPOC values. A shift in distributions is reflective of the aggressiveness of the driver group as a whole at this location. This phenomenon is not surprising, given that POV traffic is much heavier at Site B, enticing SV drivers to take more daring actions. In addition, there are no left turn pockets at this location and SV have to hold and wait in the inside lane for opportunities to turn. Furthermore, the two peaks in TTPOC distribution in Figure 3.16 are separated by a larger distance if compared to Figure 3.14. A hypothesis is that this is caused by the higher POV prevalent speed at Site B (16-20 m/sec or 35-45 mph) versus that at Site A (9-14 m/sec or 20-30 mph). The reasoning is that POV of greater speed will pose greater risks and most drivers still wait to seek a safe gap to turn, therefore shifting more distribution to the right. Despite the aggressiveness exhibited by the whole group at this site, the threat posed by high-speed traffic has an effect. This hypothesis is supported by other examples below.

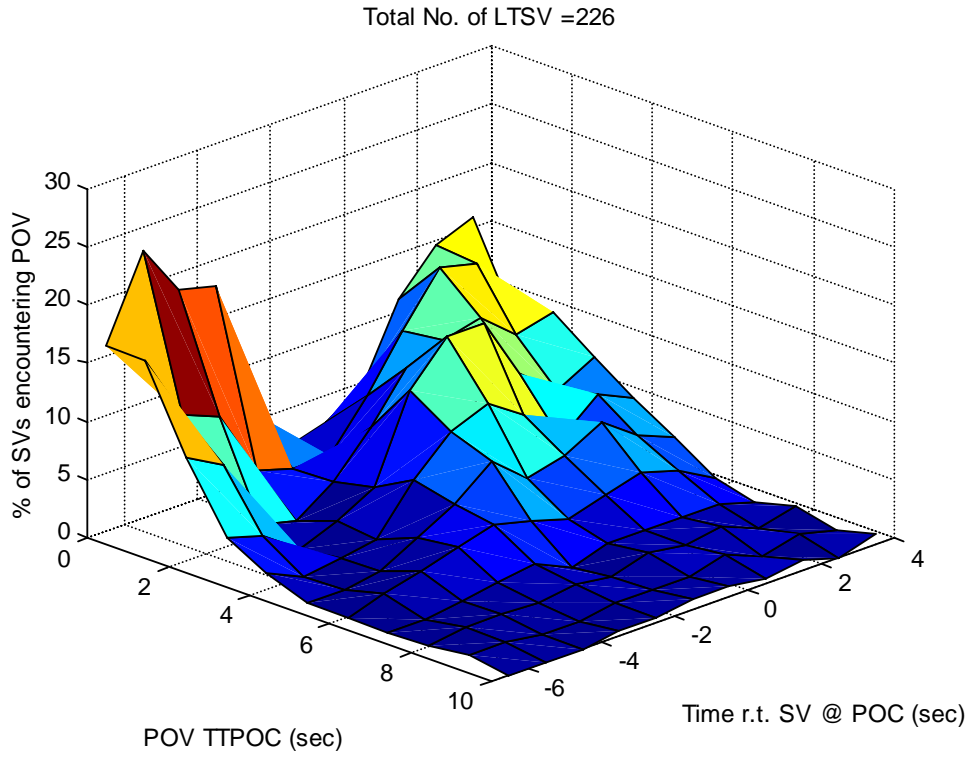

Figure 3.16 POV-TTPOC Distribution vs. Time Relative to SV Crossing POC (Site B)

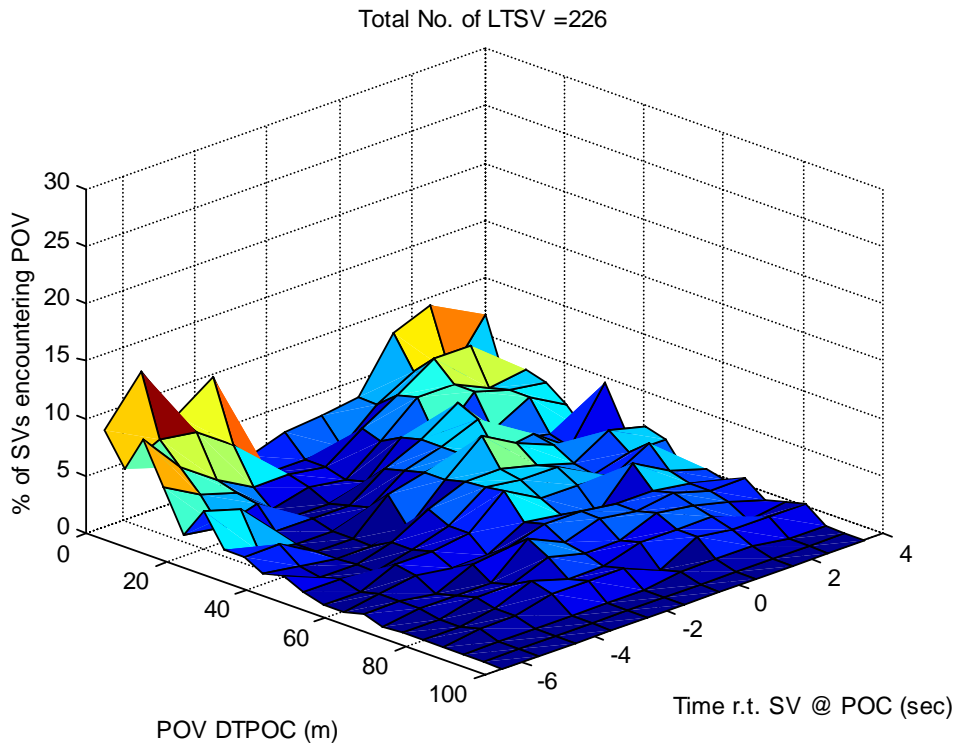

Figure 3.17 POV-DTPOC Distribution vs. Time Relative to SV Crossing POC (Site B)

Figures 4.18 and 4.19 illustrate the distribution at Site C with a total of 112 SV cases. There is also a higher ratio of closer and more threatening POV at this location when compared to Site A. One possible explanation for the shift in distributions is the short green phase duration (only 20 seconds) for SV to turn, therefore enticing SV drivers to be more aggressive. In addition, there are no left-turn pockets. The other aspect revealed by video review is that there is a considerable volume of right-turning POV from the opposite direction. These right-turning POV are much closer in distance to the point of conflict yet they are slowing down to prepare for the right-turn move as they come into positions. Many SV are found to be completing the left turn even in the presence of these right-turn POV. This contributes to the large numbers of close POV indicated at time zero in the graph.

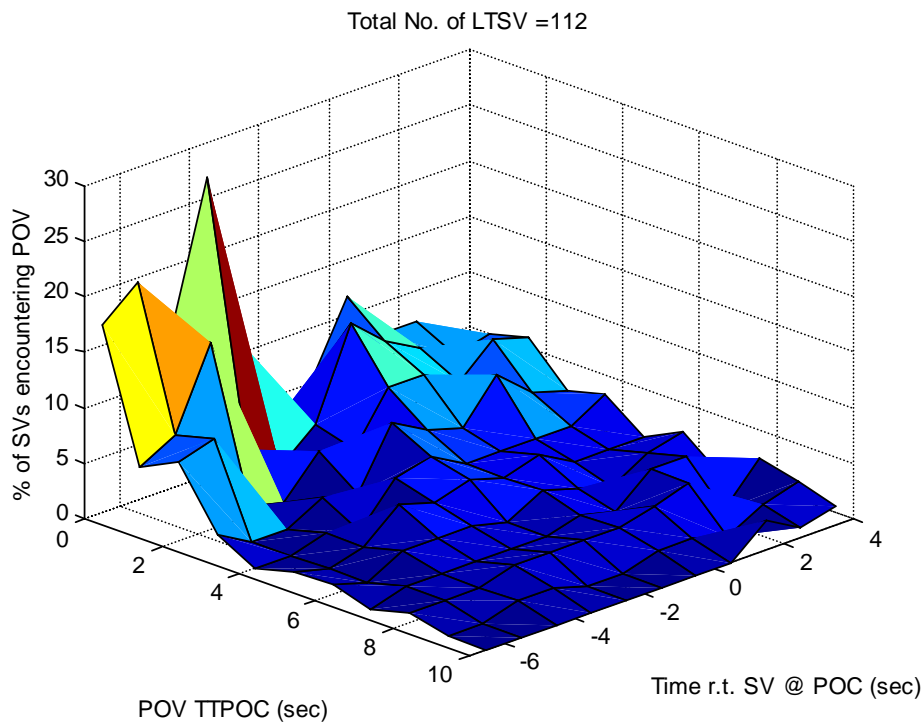

Figure 3.18 POV-TTPOC Distribution vs. Time Relative to SV Crossing POC (Site C)

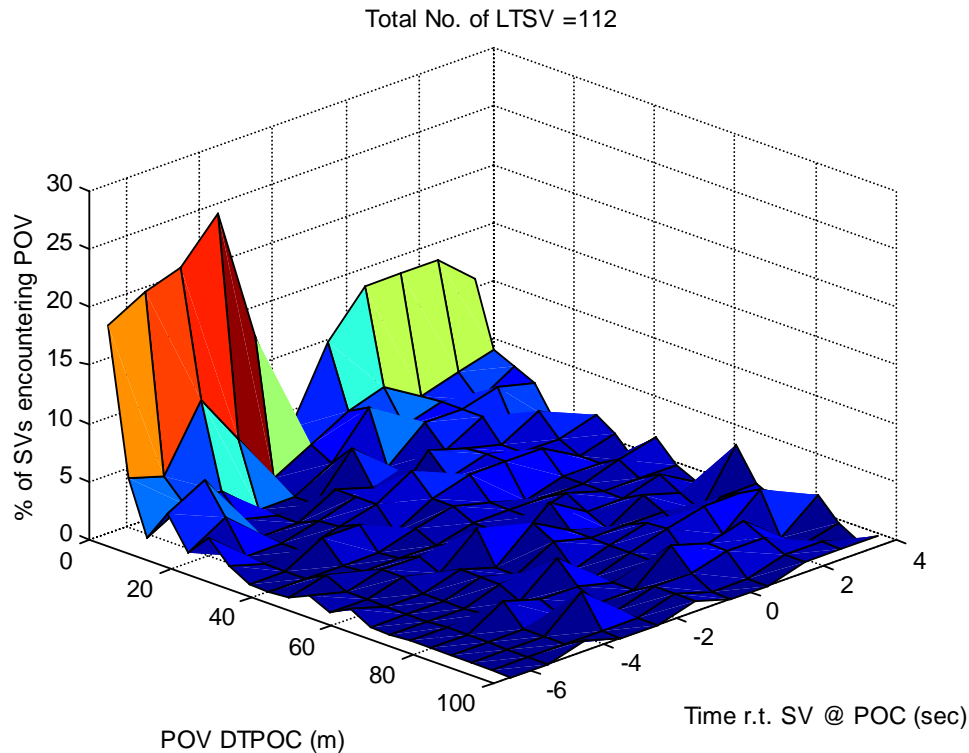

Figure 3.19 POV-DTPOC Distribution vs. Time Relative to SV Crossing POC (Site C)

It is also noticeable in the two figures that the gaps in distribution are narrower in a comparison between Site B and Site C, with the two peaks in TTPOC and DTPOC in Figures 3.16 and 3.17 closer than those in Figures 3.18 and 3.19. This is probably caused by a lower POV speed range (9-14 m/sec or 20-30 mph). For a greater percentage of SV drivers, observing and recognizing slower moving POV may encourage them to initiate and complete the maneuver even if the POV are located closer in time or space.

Figure 3.20 and 3.21 are generated for the non-signalized location of Site D. In contrast to the graphs of Figures 3.14-3.19, there is a very clearly defined, wide gap for a total of 81 SV cases. Apparently, there is minimal aggressive action taken by SV drivers, which may be due to the high POV speed range (16-20 m/sec or 35-45 mph). Additionally, there is no interaction between SV and POV motions and driver decisions enticed by signal transition since this is a non-signalized intersection. As a result, the POV distribution is significantly different from that for Sites A, B, and C.

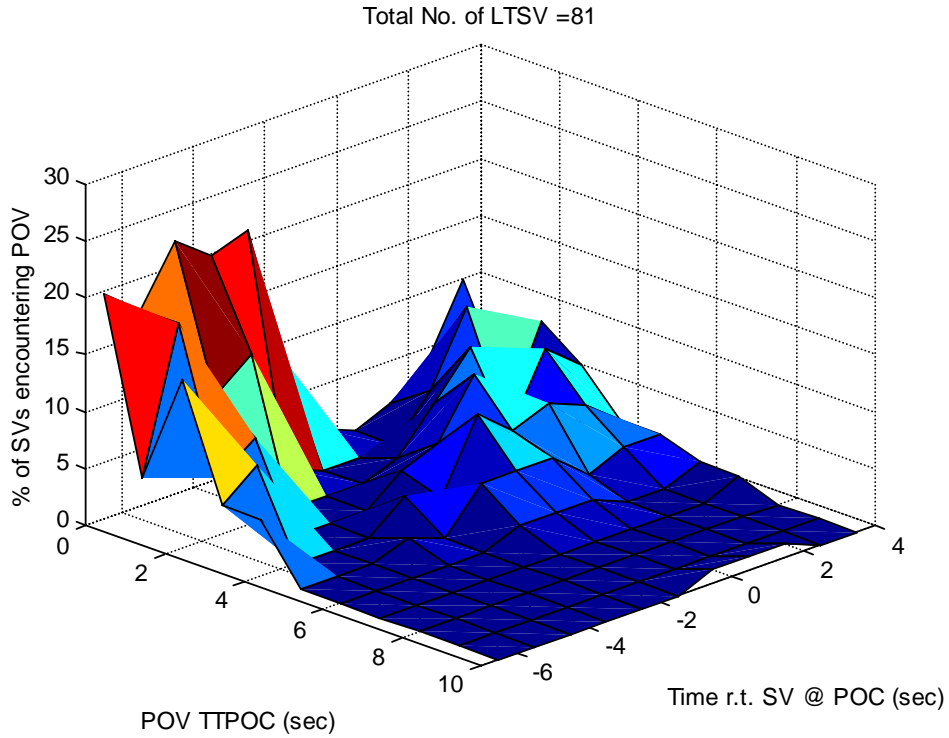

Figure 3.20 POV-TTPOC Distribution vs. Time Relative to SV Crossing POC (Site D)

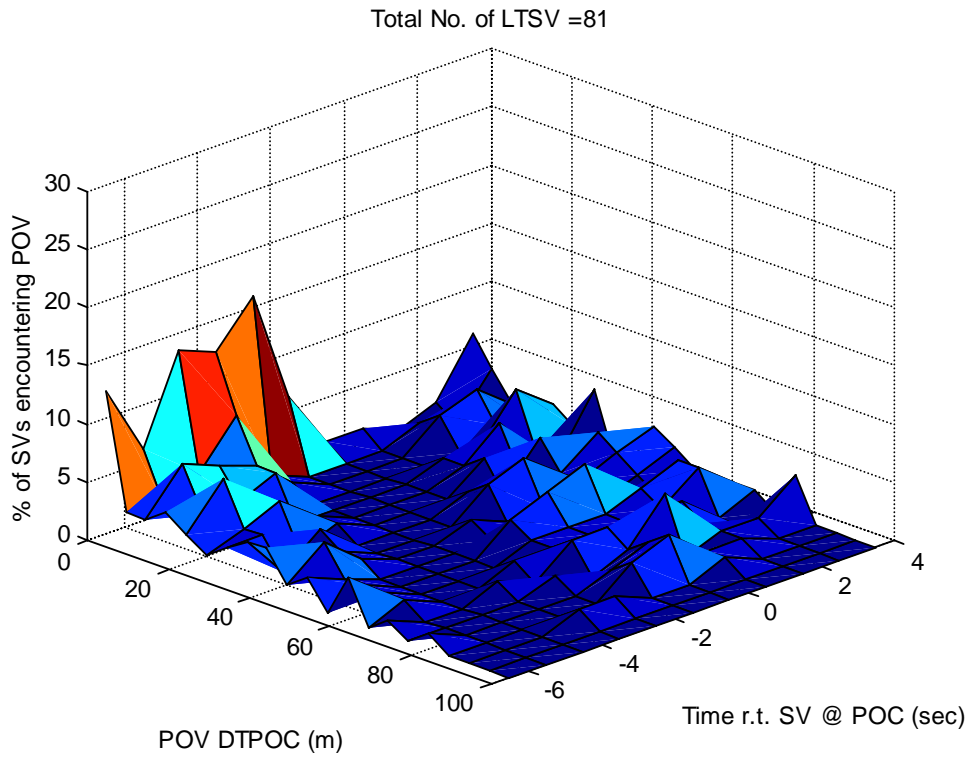

Figure 3.21 POV-DTPOC Distribution vs. Time Relative to SV Crossing POC (Site D)

Implications for IDS

1. Traffic conditions and site-specific characteristics of an intersection have significant impacts on traffic patterns and driving behaviors.
2. Field observations need to be carried out in the developmental stage at candidate sites considered for deploying IDS safety solutions. The collected field data should be reviewed to identify specific issues so that sensing strategies can be improved and proper warning thresholds can be established.

3.2.5 Time-Gap Acceptance Analysis for LTAP-OD Scenarios

One primary objective of our field observation studies was to extract from real-world data the behaviors of drivers making a left-turn movement, specifically in the LTAP-OD conflict situation. We reviewed situations of left-turning SVs and investigated criteria for appropriate time gaps for these SVs to complete the maneuver. Based on these patterns of driver decisions in real-world situations, we aim to establish the criteria for issuing warning signals in an IDS solution.

For the purpose of discussions, we will use a gap in time, or equivalently the time to intersection (T2I) of oncoming traffic, as the primary measured parameter because:

The definition of “time gap” requires some explanation. A time gap between two vehicles can be considered the time to “close the gap”, which is calculated by dividing the distance between two vehicles by their relative (closing) speed. In our case, we choose the “time gap” to satisfy the question, “How quickly will the next POV reach the intersection once the current POV passes through?” This is critical to the SV driver’s decision to commit to a left-turn movement. If there is only one POV, the SV driver will choose the time to turn by estimating the arrival time of this single POV. More properly, the time gap definition we use should be termed the “time lag.” However, for convenience of using standard terminology, we refer to the time lag as the time gap.

3.2.5.1 SV-POV Interaction

As an initial step in our analysis, SV turning cases are identified from the data as they cross the radar field of view. The POV traffic is indexed to the time when an SV is detected, with POV trajectories reduced both before and after the SV turns. Figure 3.22 illustrates two left-turn SVs with the T2I of two POVs, calculated from radar data, plotted versus time with the appearance of SV in the radar field of view used to define the time at $t = 0$. In other words, the plots are intended to show the approaching times of POV just before and after the SV passing through the point of conflict. Note that when T2I is plotted as a function of time a constant-speed approach toward the intersection appears as a straight line with a slope of -1. Note also that a stopped vehicle has an infinite T2I value. The two different color traces (blue and magenta) in the plots show the POVs in the two lanes approaching the intersection. Figure 3.22A indicates that one POV slowed down when the SV appeared in its path, causing the T2I curve to flatten. Figure 3.22B, on the other hand, shows that the approaching POV slows down due to a combination of the SV turning and a signal transition from green to amber. The two charts of POV-T2I variations illustrate the phenomena of interaction between SV and POV motions and traffic signal effects on POV motion.

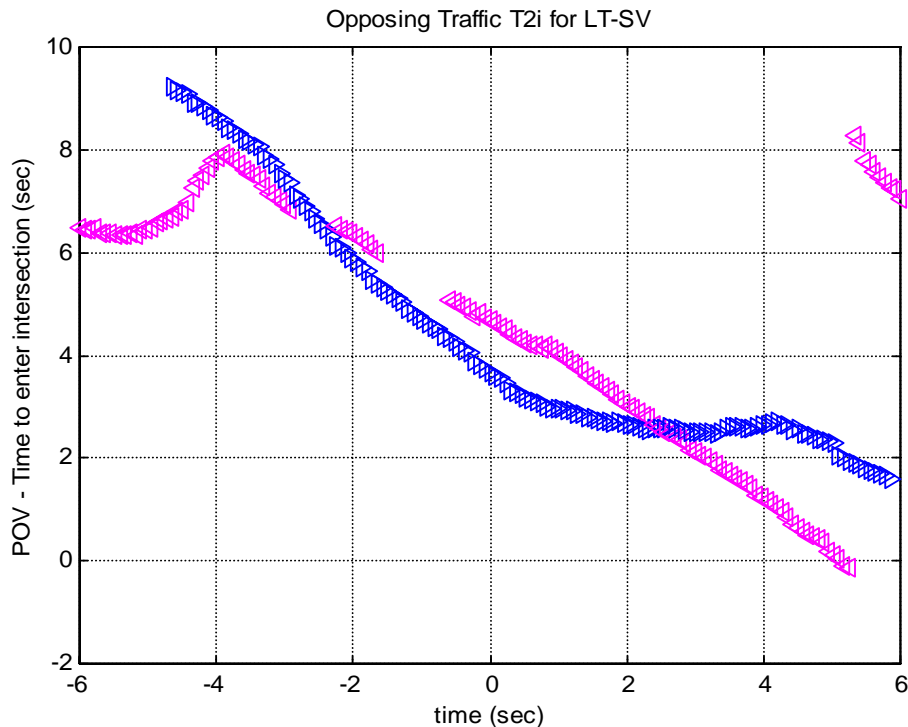

Figure 3.22A POV-T2I versus SV Detection Time, Example 1

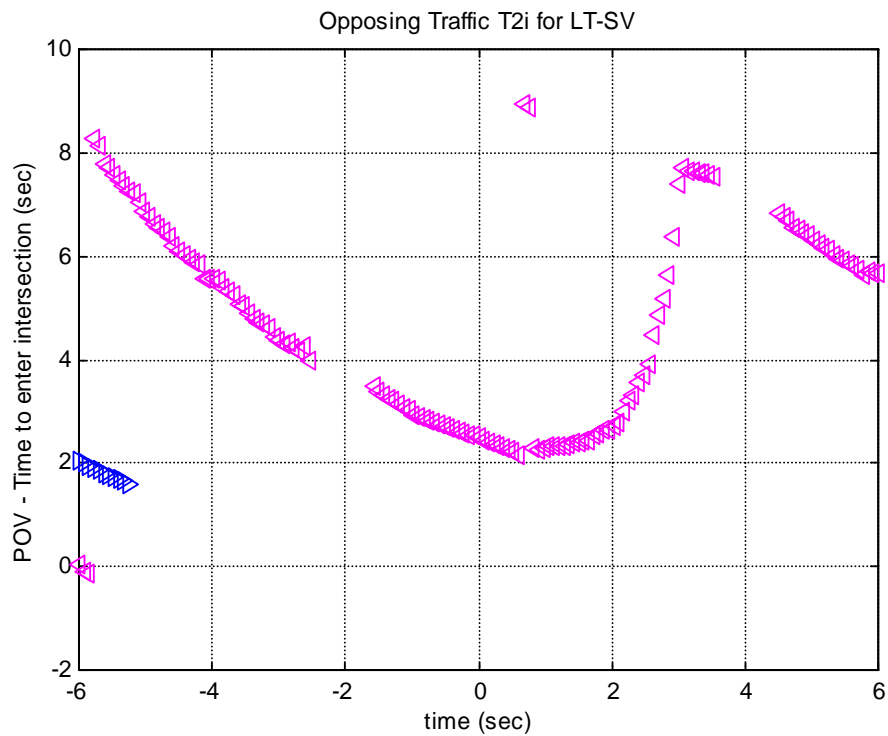

Figure 3.22B POV-T2I versus SV Detection Time, Example 2

As shown in Figures 3.22, the projected arrival times of the POVs are likely to vary with time. To illustrate this point, a total of 34 left-turn SVs were counted through a period of observation for the same data set used for Figure 10, and the aggregate chart tracking those POVs in all cases is plotted in Figure 3.23. In this figure, the estimated POV T2I values at $t = -4$, -2 , and 0 seconds are used to project POV arrival times at the intersection, and the number of POVs projected to arrive within each subsequent one-second time interval is counted and plotted in the bar graphs. The heights of the bars (number of POVs) change quite significantly over time.

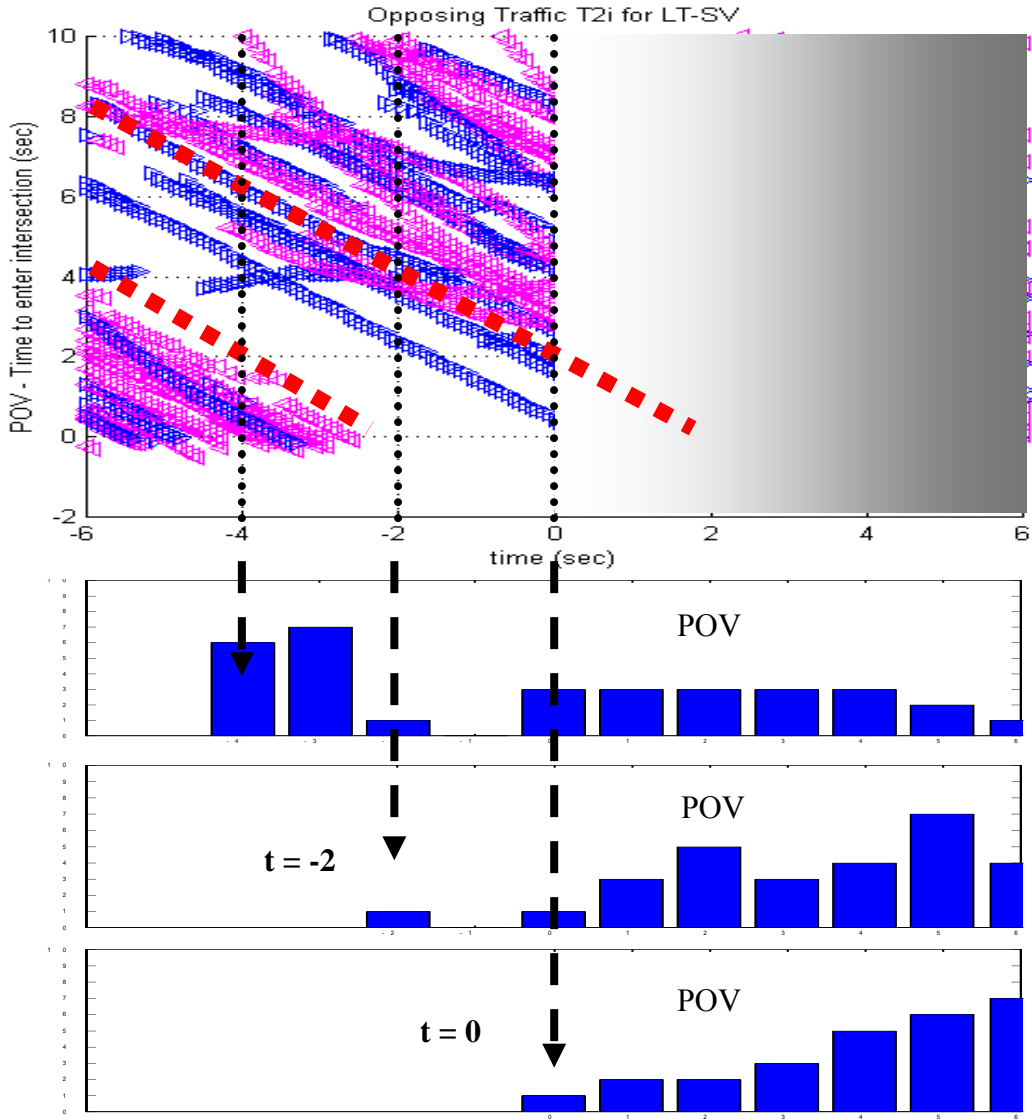

Figure 3.23 Aggregate POV T2I Trajectories versus SV Detection Time and Distributions of Anticipated Arrival Times of Approaching POVs

Figure 3.24 is a timeline showing the sequence of events for a left-turning subject vehicle. The bars along the timeline indicate the duration and the relative timing of associated events. Note that the overlapping windows can change in different situations.

To understand the acceptance of POV gaps by SV drivers, we need to monitor the time sequence of the left-turn event and the point of decision-making when SV drivers perceive the situations to be safe. In other words, the acceptance of POV time gaps as exhibited in Figure 3.23 should be evaluated relative to the time of decision-making by SV drivers as depicted by Figure 3.24 before the initiation of the left turn.

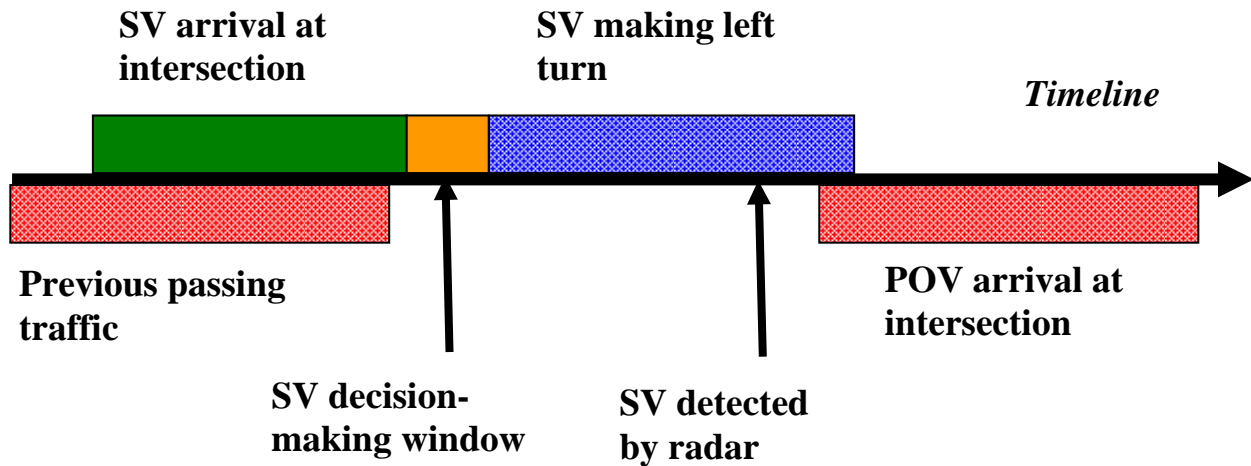

Figure 3.24 Time Sequence of SV-POV Interaction

Since the tracking of SV movements is not fully provided by the radar in our observation, we resort to the video images for supplementary information. Hence, a video review tool was constructed to allow frame-by-frame inspection of video images. Through video review, a range of turning times used by SV drivers was established. A table containing more than 100 samples of left-turn SVs is given in Table 3.2.

Table 3-2 Observed Turning Times of SVs under Various Conditions

Type of Turn	Number of Observations	Mean Turning Time* (s)	Standard Deviation (s)
Pedestrian present in destination crosswalk	22	4.4	1.5
On the fly (without stopping)	16	2.8	0.5
From queue (waited for preceding vehicle)	11	3.1	0.4
During amber or red signal	27	2.9	0.5
All other**	41	3.1	0.5

* Time from first significant turning to clearing POV lane

** Waiting for gap during green, with no pedestrians present in destination crosswalk

To correlate SV turning time with the POV movements, we use the mean values of the turning time from a group of samples. For example, the last row in Table 2 offers a total of 41 drivers in the same situation of waiting for a gap in POV traffic with no pedestrians present in the destination crosswalk. Thus, we can reasonably assume that the driver decision to initiate the turn is primarily based on their observation of the POV traffic. By reviewing all SV cases in the table, it can be seen that except for those cases when pedestrians were present, the SV took approximately 3 seconds to complete the turn.

With the radar at the field observation setup detecting the SV near the end of their turn as indicated by Figure 3.2, we can assume that the time of SV detection is very close to the end of the turning maneuver. By combining this observation with the turning time based on video data from Table 3.2, we use the mean value of 3-second turning time for our analysis. It is further noted that the opportune instant to provide an advisory signal to the driver should be prior to the decision-making window. This will allow the driver to take into account the advisory alert in addition to his/her own judgment of the traffic conditions. For the purpose of this discussion, we will assign a perception period of 1 second.¹¹ The length of the perception period refers to the time needed for the SV driver to inspect the traffic signal, the oncoming traffic, pedestrians and the surrounding environment to make a decision to start the turn. In all, we will assume that SV drivers assess the POV arrivals at 4 +/- 0.5 seconds before $t = 0$. Current IDS and future CICAS research is collecting data to support a more definitive identification of the most appropriate time to assume here.

Figure 3.25 shows the observation data from the same data illustrated in Figure 3.23, when the traffic was relatively light. In Figure 3.25A, the numbers of POVs are counted based on their projected arrival time, from $t = -5$, -4 , and -3 forward but excluding those arriving at $t = -2$ or before. The bar graph represents the numbers of POVs expected to arrive in each one-second time interval before or after the SV arrival, evaluated for all SV cases in this data set. Those POVs arriving before $t = -2$ were excluded because they have already passed the intersection and are therefore not germane to the crossing-path conflict. As a reference, the numbers projected from $t = -5$ and $t = -3$ are also shown to be compared to those from $t = -4$, which is the assumed decision-making point in time explained above, in the same chart.

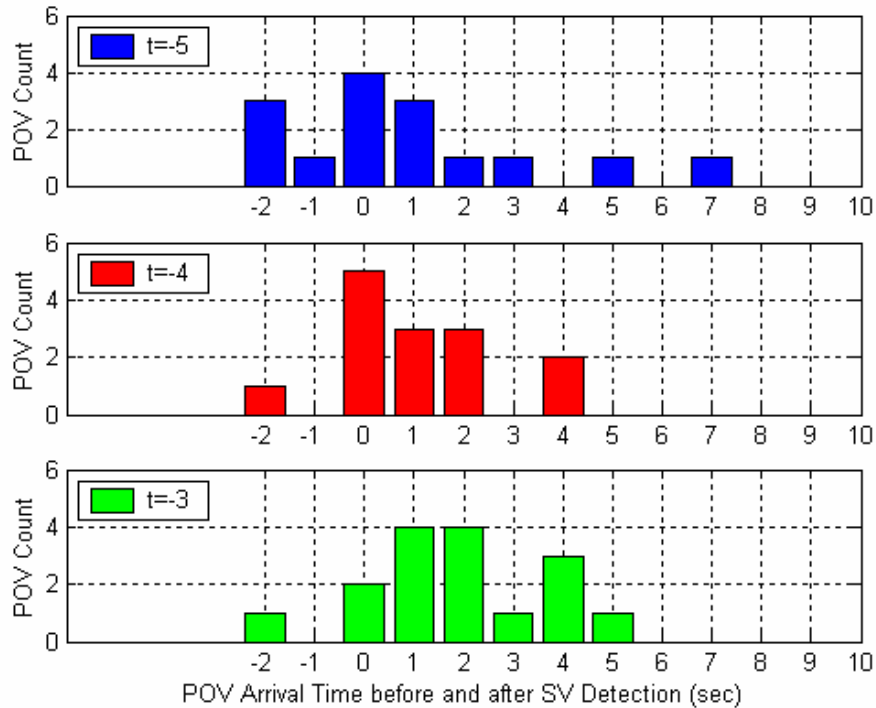

Figure 3.25A POV Counts of Projected POV Arrival Time versus SV Detection Time for Three Different Values of Assumed SV Turning Decision Time, Data Set 1

Figure 3.25B depicts the cumulative percentage by summing the POV arrival estimates from Figure 3.25A, and, to normalize, by dividing the cumulative POV counts by the total number of left-turning SVs. Based on the reasoning above, the curve reveals the gap-acceptance of POV-T2I with respect to the decision instant before the SV initiates the left turn. To understand the chart, consider that:

The curves in Figure 3.25B will shift to the right if the assumed period of pre-turning and actual-turning takes longer and to the left if the period is shorter. (See the different starting points in time for the three illustrated scenarios, $t = -5$ to -3 seconds.)

The curves flatten at an acceptance level approaching around 50% because in about half the cases there were no POVs in view or the projected T2I was further to the right of the chart at the time of the turn.

As an example, from reading the plots, for $t = -4$ about 20% of SV drivers choose to make the turn when POV-T2I is 4 seconds or less, while 40 % of SV drivers do so when POV-T2I is 6

seconds or less. The 20% and 40% numbers are referred to as “acceptance ratios”, i.e., the percentage of drivers that accept the presented gap.

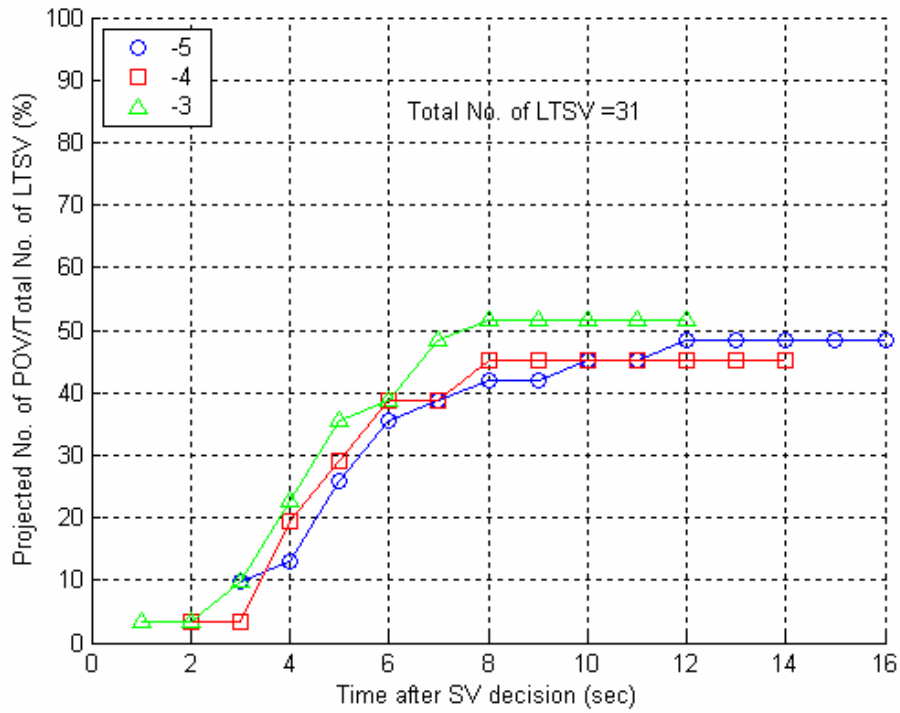

Figure 3.25B Cumulative Percentage of Gap Acceptance versus SV Decision Time, Data Set 1

To use the curves of T2I distribution as the basis for selecting the threshold for issuing warning signals, the percentage of T2I acceptance represented by the curves will indicate how closely the selected threshold matches the decision criterion used by the observed SV drivers.

The three curves are very similar in shape and close to one another. This means that in this data set the distribution of POV-T2I acceptance is insensitive to SV decision time.

However, the percentage deviation (obtained by reading the vertical axis) of gap acceptance ratios between the three curves is approximately 10% or less between time after SV decision = 3 seconds to 10 seconds along the horizontal axis. This implies that if a warning is to be issued in the range of $t = -5$ to -3 seconds, our assumed driver decision window, the deviation in gap acceptance ratio will not exceed 10%. Gap acceptance may therefore be insensitive within this particular T2I range, which implies some design latitude in the time needed to issue warnings.

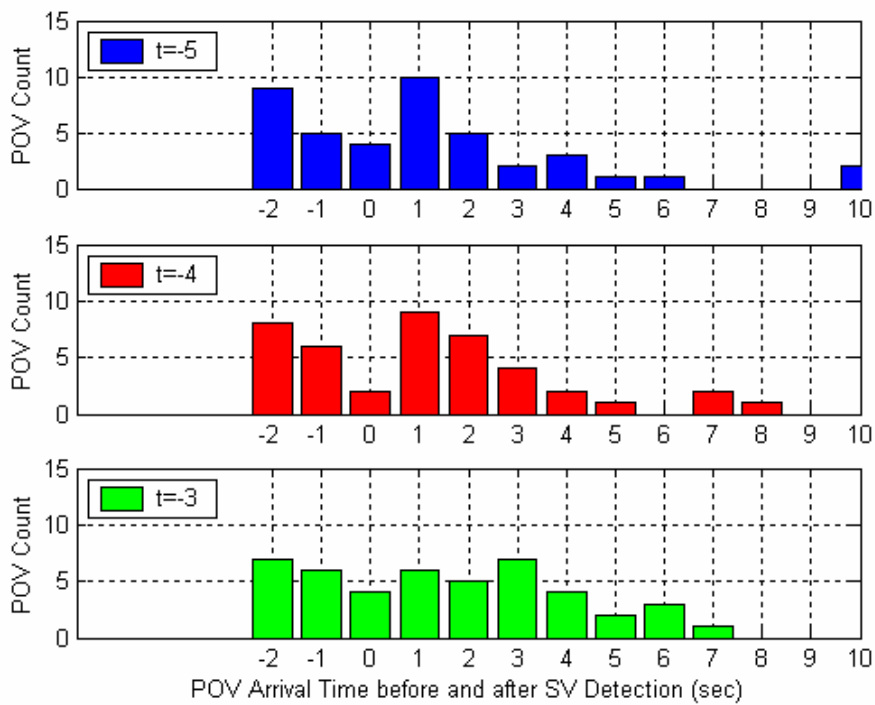

Figure 4.26A POV Counts of Projected POV Arrival Time versus SV Detection Time for Three Different Values of Assumed SV Turning Decision Time, Data Set 2

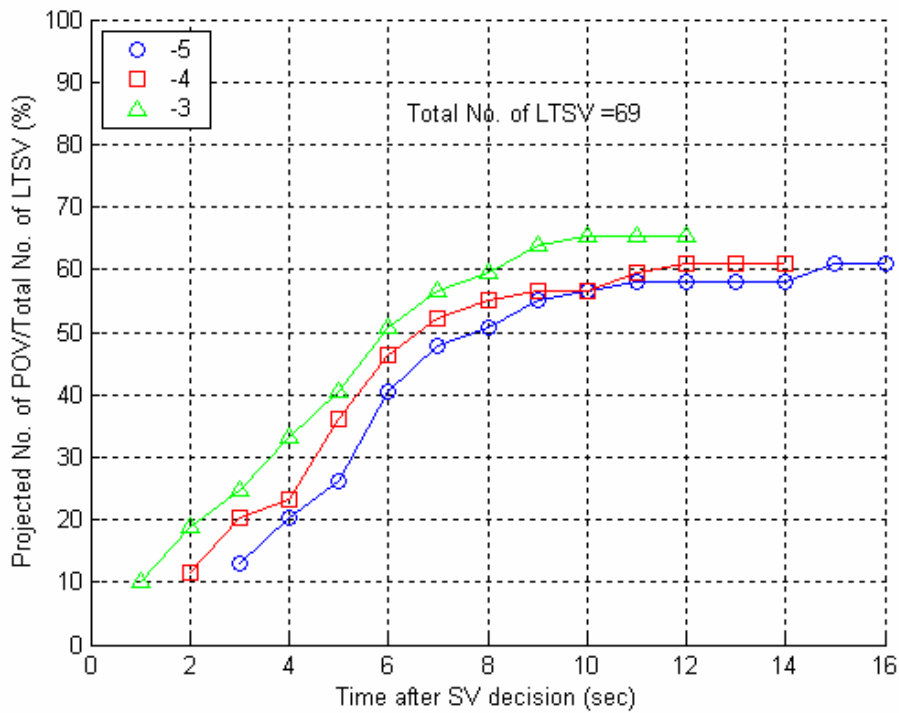

Figure 4.26B Cumulative Percentage of Gap Acceptance versus SV Decision Time, Data Set 2

Figure 3.26 shows the results obtained by the same analysis with another data set at the same intersection, when the traffic volume was larger. In this set of data, it should be noted that a larger portion of SVs made the left turn near the end of the green phase or in the amber phase, due to the heavier traffic. The following is noted:

The curves flatten at a higher percentage, which reflects the heavier traffic, yet still remain below 100%.

The curves are higher in Figure 3.26B than in Figure 3.25B, which means that a greater percentage of SV drivers choose to make the turn at any given POV-T2I threshold.

The deviations between the three curves are close to 10% from time after SV decision = 6 to 10 seconds along the horizontal axis, but are wider (close to 15%) from time after SV decision = 3 to 6 seconds.

Clearly, drivers exhibit different behaviors in different observation data sets from the same intersection. The primary factor that may have caused the shift of driver behaviors shown in Figures 3.26 is hypothesized to be the heavier traffic, which may have induced a larger number of late-stage turning in the green phase. Figure 3.27 offers a comparison of behaviors by excluding the late-turning cases from data in Figure 3.26. Excluded cases are those that turned in approximately the last 3 seconds of the green and in the amber phase. It is noted that:

There is a noticeable drop in numbers of POVs with relatively short T2I, for example in the range of $t = -2$ to 0 in Figure 3.27A, when compared to Figure 3.26A. This confirms the hypothesis that late-turning in signal phases will cause a shift or distortion in the distribution curves.

The curves in Figure 3.27B have very similar shapes when compared to those curves in Figure 3.26B, but they possess higher acceptance ratios, after excluding the late-turning cases from Figure 3.26B. This implies that this SV driver group overall is more aggressive than those

depicted Figure 3.25B, even if the late-turning cases are excluded. Again, the heavy traffic condition is a likely factor.

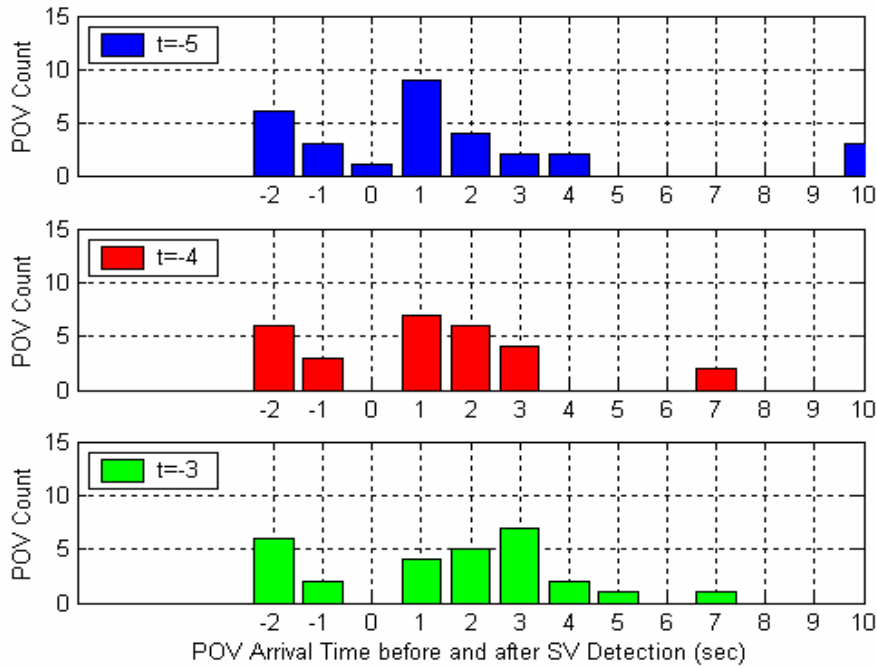

3.27A POV Counts of Projected POV Arrival Time versus SV Detection Time for Three Different Values of SV Turning Decision Time, Data Set 2, Excluding Late Turns

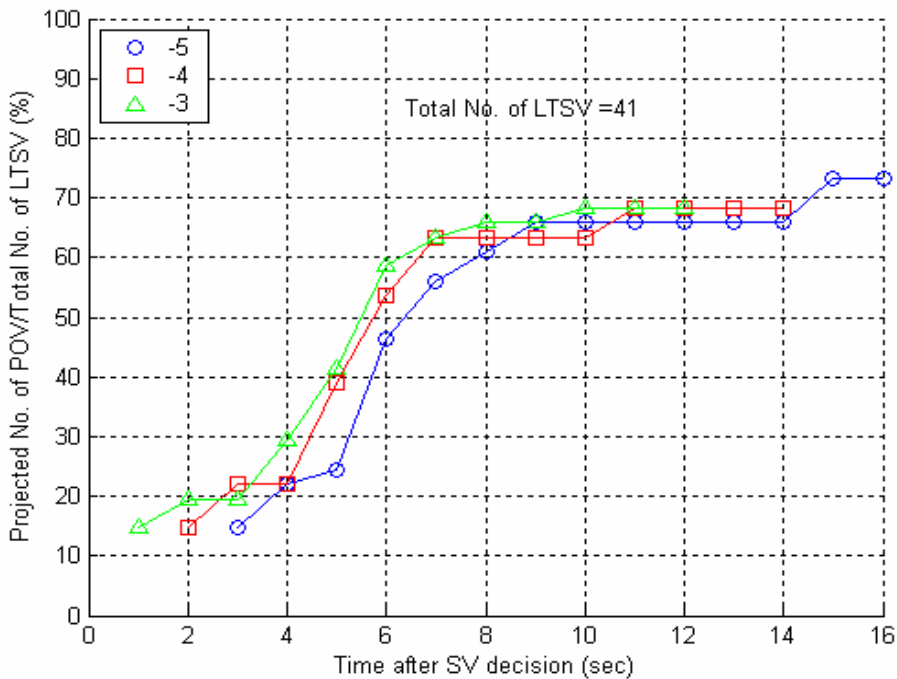

3.27B Cumulative Percentage of Gap Acceptance versus SV Decision Time, Data Set 2, Excluding Late Turns

The deviations among the three curves in Figure 3.26B and 3.27B are wider in the shorter-time range than the longer-time range. This implies that the interactions between POVs and SVs are more evident when they are closer, particularly in this data set collected in heavier traffic conditions.

For the use of data analysis illustrated in the figures above, a few considerations are required for establishing and selecting the criteria for providing warning signals and timing design for an IDS safety system. First, a carefully constructed set of representative field observations is necessary. We believe the field observation should also be augmented by human factors evaluation studies under controlled driving experiments. Secondly, sensing methods to track the locations and movements of SV can certainly offer additional information to establish a better matching of SV-POV interaction in time. Nevertheless, despite the inexactness in the estimate of the SV decision-making time, the distribution curves can still be a first-order approximation for time gap choices. This preliminary criterion extracted from field observations, in turn, can be fed back to the further studies to determine the appropriate time gap that drivers may use to make left turns.

Implications for IDS

1. The time gap acceptance behaviors for LTAP-OD scenarios can be projected and estimated from field observation data.
2. The most critical cases from observations are those situations where SV turning occurs with the POV arriving within a short trailing buffer. The overall distribution of time-gap acceptance allows us to understand the range of time gaps and the percentage of cases that are warranted for warning.
3. The behaviors of time-gap acceptance vary with traffic conditions and intersection attributes. Therefore, the warning algorithms may need to be adjusted to accommodate the local design needs.

3.3 Conclusion

The effectiveness of these safety systems depends on the timely generation and communication of alert signals to drivers so that actions can be taken to avoid or mitigate collisions. In order to establish a baseline of warning criteria for IDS design, field observations were conducted to gather information about real-world traffic data.

Field data from several observation sites were used to illustrate the traffic conditions, under which drivers elect to initiate left-turn across-path opposite direction (LTAP-OD) maneuvers. It was found that intersection and traffic characteristics, such as signal cycle and vehicle speed, can have meaningful impacts on driver behaviors. In addition, we developed a methodology for estimating the time-gap acceptance exhibited by drivers in real-world traffic conditions.

The study presented in this report represents an important initial step in the establishment of appropriate warning thresholds for the implementation of driver assistance and collision warning systems. Further in-depth understanding of driver decision-making and risk-taking behaviors can enhance the robustness, reliability, and effectiveness of the envisioned safety systems. The investigation of design parameters and warning criteria in accordance with driver behaviors under various traffic conditions at different types of intersections remain the topics for future studies.

4 VIDEO OBSERVATIONS OF LTAP-OD MANEUVERS: DESCRIPTION OF BASIC FINDINGS AND IMPLICATIONS FOR IDS

4.1 Executive Summary

4.1.1 Rationale and Methods

One of the activities in support of the LTAP-OD project has been an analysis of driver behavior at actual intersections using both video and radar as observation tools. This report (i) summarizes the analyses of video data gathered at five different intersections in the San Francisco Bay Area from October 2, 2003 to October 14, 2004 and (ii) develops implications for IDS systems for preventing LTAP-OD collision.

A total of 12 ³/₄ hours of video recordings were collected at these five intersections. For the current analyses, we focused on gap acceptance/rejection and turning time for each of the intersections. Specifically, for each intersection, we assessed:

- iv) Distribution of gap availability
- v) Probability of gap acceptance by length of gap (“gap acceptance curve”)
- vi) Distribution of turning times

Following is a summary of results and implications for IDS.

4.1.1.1 Distribution of available gaps

In the distribution of gaps in traffic for all intersections combined, gaps of two, three, and four seconds were more frequent than other gaps, but the distribution was highly skewed to the right. While the general shape of the distribution was similar for all five intersections, the position and dispersion varied considerably, reflecting variation in length of available gaps. Taking the percent of gaps below 12 seconds as a measure, intersections varied widely, from 74 percent,

reflecting a very high POV volume, to 14 percent, reflecting a relatively low POV volume. Intersections with a higher percentage of gaps *below* 12 seconds would make it more difficult for an SV driver to find adequate gaps and may lead to a driver to attempt an LTAP-OP maneuver during an inappropriate gap in traffic due to impatience. Intersections with a smaller percent of gaps below 12 seconds make it easier for an SV driver to find an adequate gap, but may reduce a driver's expectation that a POV will appear. Gaps presented to the SV driver can be adequately described by a log-normal function.

Implication for IDS: Given dramatic differences in gap availability across intersections, it is crucial to know whether gap availability impacts the behavior of SV drivers. If gap availability affects SV driver behavior, then factors that affect gap availability should be identified. Different patterns of gap availability also will affect the frequency of alerts, which in turn make impact driver behavior. Use of the log-normal function can be used to characterize gap availability patterns at different intersections and times of day, and can be used in simulation models to generate different patterns of available gaps.

4.1.1.2 Gap acceptance by length of gap (Gap acceptance curve)

Taking all intersections together, all gaps below 3 seconds were rejected, and all gaps above 11 seconds were accepted. For gaps 3 to 11 seconds we calculated the percent of gaps that were accepted by the SV driver. For all intersections combined, the probability of a gap being accepted increased incrementally by gap length. This “gap acceptance curve” approximated a logistic function with upper and lower boundaries of 0 and 100 percent. For individual intersections the general shape of the gap acceptance curve was similar. For each intersection, the range from no gaps accepted to all gaps accepted at each intersection was substantial, between 5-6 seconds, indicating a fairly wide range in SV gap choice.

Implications for IDS: It is assumed that it will be difficult or impossible to predict gap-acceptance behavior of *individual* SV drivers in order to adjust the IDS warnings. The wide gap acceptance curve at each intersection means that IDS algorithms designed to warn drivers of dangerously short gaps in oncoming traffic would have to accommodate a fairly

wide range of behavior and expectations by SV drivers. A warning that feels appropriate for some drivers may not be adequate for a large number of other drivers. Therefore, it is critical to study SV drivers' reactions to different warnings.

While the general shape of the gap acceptance curve was similar across intersections, the position (along the dimension of gap lengths) and slope (steepness) varied considerably across intersections. A parameter in the logistic function describing the gap acceptance curve is the gap length at which 50 percent of gaps are accepted. Intersections varied on this parameter widely, from a low of 5.7 seconds to a high of 11.3 seconds. Slopes also varied substantially. While there is some uncertainty in these estimates due to a relatively small sample of observations, it is clear that the position and slope of the gap acceptance curves differs substantially across intersections.

Implications for IDS: To the degree that the IDS warning algorithms need to accommodate patterns of gap acceptance, calibration will be needed for individual intersections. If gap acceptance behavior at an intersection varies also by other conditions (e.g., gap availability), then adjustments might be necessary for changes in such conditions over time at each intersection.

The fact that the gap acceptance curve approximates a logistic function suggests that models of the gap acceptance curve can help describe and differentiate intersections (or changes within intersections) by specific parameters in the models. This should be explored in future research.

4.1.1.3 Turning Time by Intersection

Drivers must choose gaps to allow time for them to make the turn. The distributions of turning times were similar across the five study intersections, with skewness to the right. With respect to variability, the standard deviation ranged from 0.7 seconds to 1.4 seconds. Drivers with shorter turn times may find shorter gaps to be comfortable, whereas drivers with longer turning times may find shorter gaps to be unacceptable. We might expect that turning time and length of gap

accepted would be closely correlated. However, we found a low correlation between these two variables.

Implication for IDS: Wide variability in turning time within intersections means that IDS warning systems at any particular intersection will need to accommodate a wide range of drivers. This makes it crucial to determine the reaction of drivers to warnings that don't closely match expectations based on their usual behavior.

Although the turning time distributions of the five intersections were all similar in shape, they differed by position. For example, average turns times ranged from a low of 2.6 to 4.4 seconds, a difference of 1.6 seconds. The 85th percentile of turns ranged from 3.0 to 5.6 seconds across intersections, a difference of 2.6 seconds.

Implication for IDS: SV drivers with longer turning times will require earlier detection of the POV by the IDS algorithm than those with shorter turning times. Therefore, the points of minimum detection of a POV will vary substantially by intersection. The IDS algorithm needs to be adapted to each intersection.

4.1.1.4 Turning Time by Type of Turn

Driver turning time also varied according to the type of turn. Types of turns differed by pre-turn SV position, signal phase, and presence of pedestrians. Left-turn categories included “on the fly” (i.e., turns without stopping), “from queue,” “in yellow or red,” and “turn during green (with no queue or pedestrian).” For all intersections combined, average turning time was highest for “pedestrians present” (4.6 seconds), while turns “on the fly” had the lowest average turning times, at 2.6 seconds, a difference of almost two seconds. Turns with “pedestrian present” also had the highest variability, with a standard deviation of 1.8, while turns “on the fly” had the lowest variability, with a standard deviation of 0.5. Although intersections differed by overall average turning time, the patterns for different types of turn had the same ranking.

Implication for IDS: If warning times are given for the longest turns at each intersection, then drivers making inherently shorter turns could consider the warnings unnecessary and come to ignore them. The IDS warning algorithm could be more precise if the type of turn could be detected. Research should be done to determine if the type of turn can be anticipated in time to influence the timing of the warning. This might be done to some degree by taking signal phase and SV position into account.

The substantial increase in average turning time when pedestrians were present merits close attention. Observations indicated that SVs were frequently stranded in the intersection in the midst of a turn while waiting for a pedestrian. Pedestrian presence may impact on SV turning times and may also impact on intersection capacity by blocking POV traffic as well.

Implications for IDS: Given the potential impact on safety and intersection capacity, it is crucial that the IDS warning algorithm account for pedestrians in intersections that have frequent pedestrian crossings. This might be accomplished by providing a pedestrian detector as a part of the IDS system, and providing a warning to the SV driver when a pedestrian is detected.

4.2 Introduction

The Intersection Decision Support (IDS) Project was developed by the Infrastructure Consortium (comprised of US DOT, California DOT, Minnesota DOT and Virginia DOT) to reduce crossing path (CP) crashes at intersections using emerging Intelligent Transportation Systems (ITS) technologies.

The focus of the California effort to date has been on Left-Turn Across-Path (LTAP) collisions. Vehicles making a left turn (Subject Vehicle, SV) do not have the right of way and so they must choose a safe gap in traffic in oncoming traffic (Principal Other Vehicle, POV). The likelihood of a crash increases when SV drivers underestimate the approach speed of the oncoming vehicle(s) and/or underestimate the time they need to complete the left-turn maneuver. This can be exacerbated if the SV driver's view is obstructed and/or the SV driver is not paying sufficient

attention. The California team has worked to develop an IDS system to reduce the probability of these collisions by assisting the SV driver in the detection and decision making process.

One of the activities in support of this effort has been an analysis of behavior of SVs and POVs at actual intersections using both video and radar as observation tools. This report (i) summarizes the results of analyses of video data gathered at five different intersections in the San Francisco Bay Area from October 2, 2003 to October 14, 2004 and (ii) develops implications for developing IDS systems for LTAP-OD collision.

The main objectives of these video analyses were to:

- Provide understanding of SV and POV movements for input into development of the LTAP-OD advisory algorithm;
- Determine which parameters have a significant influence on vehicle movements and vehicle interaction (e.g., presence of pedestrians, vehicle volumes, vehicle speeds, etc.);
- Develop standard methods or tools to be used in deployment of an LTAP-OD warning system, for example, in adjusting the advisory system to a particular intersection and/or set of conditions.

4.3 Background

The IDS system as presently conceived for preventing LTAP-OD collisions has three crucial real-time functions: (i) monitor movements of SVs and POVs, (ii) identify vehicle movements that increase collision risk when risk is detected, and (iii) provide information about risk to the SV drivers.

The focus of the system is on the SV driver. In the LTAP-OD scenario, the task for the SV driver is to identify an appropriate opportunity make the left turn. If there are oncoming vehicles, then the task is to identify an adequate "gap" in oncoming traffic for making the left turn.

We have defined a "gap" as the time between when the SV can reasonably be assumed to be ready to initiate the turning maneuver and the arrival of a POV¹². When a series of POVs are traveling through the intersection, the gap is defined as the time between two consecutive POVs (from the rear bumper of the first POV to the front bumper of the following POV) while the SV is waiting to turn¹³. When the SV is ready to initiate a turn following waiting in a queue or at a red light, the gap is the time from that moment until the arrival of a POV.

An "accepted gap" is one that is chosen by the SV driver to actually initiate and complete a left turn. In some cases, there may be no POV, or the POV may be at a considerable distance from the intersection. In the former case of course there is no measured gap. In the latter case the concept of a gap has limited meaning, since the SV driver may not be "choosing" a gap but simply proceeding without even considering the POV. "Accepted" gaps of 12 seconds or longer were not assessed for length because the POV was too distant to be considered by the SV driver. Virtually all gaps 12 seconds and above were accepted. A "rejected" gap is one not chosen by the driver at the moment that the SV driver can be assumed otherwise to be ready to initiate a turn.

Whether or not the SV "accepts" or "rejects" it, the actual gap can only be measured *exactly* after it has occurred. But, of course, the SV driver must accept or reject a gap that can only be estimated at the moment when a decision must be made. One source of uncertainty lies directly with the SV driver. The SV driver may misjudge the speed or distance of the POV and/or may

err in using whatever information perceived about the POV's speed and distance. Another source of uncertainty is that the POV may change speed after the point of decision after the SV driver has decided to accept or reject a gap. The process of "predicting" the gap size may be further impeded by limited information (e.g., impaired visibility) or inattention of the SV driver.

It is assumed that the SV driver is assessing the available gap, and comparing it to the turning time he/she needs to complete the turn.

4.3.1 A Driver "Model" for Choosing a Gap and How IDS Can Help

Not much is known about the process that SV drivers use when they decide to accept or reject gaps. Hypothetically, the process can be described in terms of three components:

- First, the SV driver makes a judgment about the length of the gap (i.e., time between two POVs) or lag (i.e., the time between opportunity [e.g., green light, arrival at the intersection] and the arrival of a POV)¹⁴.
- Second, the SV driver makes a judgment about the time needed to complete the turn across the intersection. Presumably, the SV driver makes an allowance for error by adding a margin for error, or a buffer, to the judgment turning time.
- Third, the SV driver makes a decision to turn or not turn based on a sense of whether the estimated gap is larger than the estimated turning time plus the buffer.

After the SV driver has made the commitment to turn, and the turn is irrevocable, the outcome can only be affected by changing speed. For example, if the POV has accelerated, the SV driver might need to accelerate to clear the path. If a pedestrian appears, the SV driver might need to stop in mid-turn. These two events might happen simultaneously and create conflict.

A conflict can occur if (i) patterns of traffic are not unusual but the SV driver either has limited visibility and/or is distracted or (ii) the driver is attentive and has all information, but something

unexpected occurs (e.g., the POV accelerates, SV is suddenly blocked by a pedestrian), and there is not time for the SV driver to make an adjustment.

The role of the IDS system is to support the process through which the SV driver decides to turn. The role is not to supplant or interfere with this process. Therefore, it is important that the IDS system does not harm (i.e., it must not distract the SV driver or create unrealistic expectations about the level of risk, one way or the other). The presumption is that the IDS system can:

- i) Gather better information about an oncoming POV's speed and distance;
- ii) Provide a better estimate of the POV's trajectory;
- iii) Make better use of this information in anticipating the available gap.

The following presents a simplified model of the gap acceptance decision process of an SV driver, indicates where research is needed, and identifies points at which IDS might help provide information in support of the process. The model assumes the three general tasks listed above.

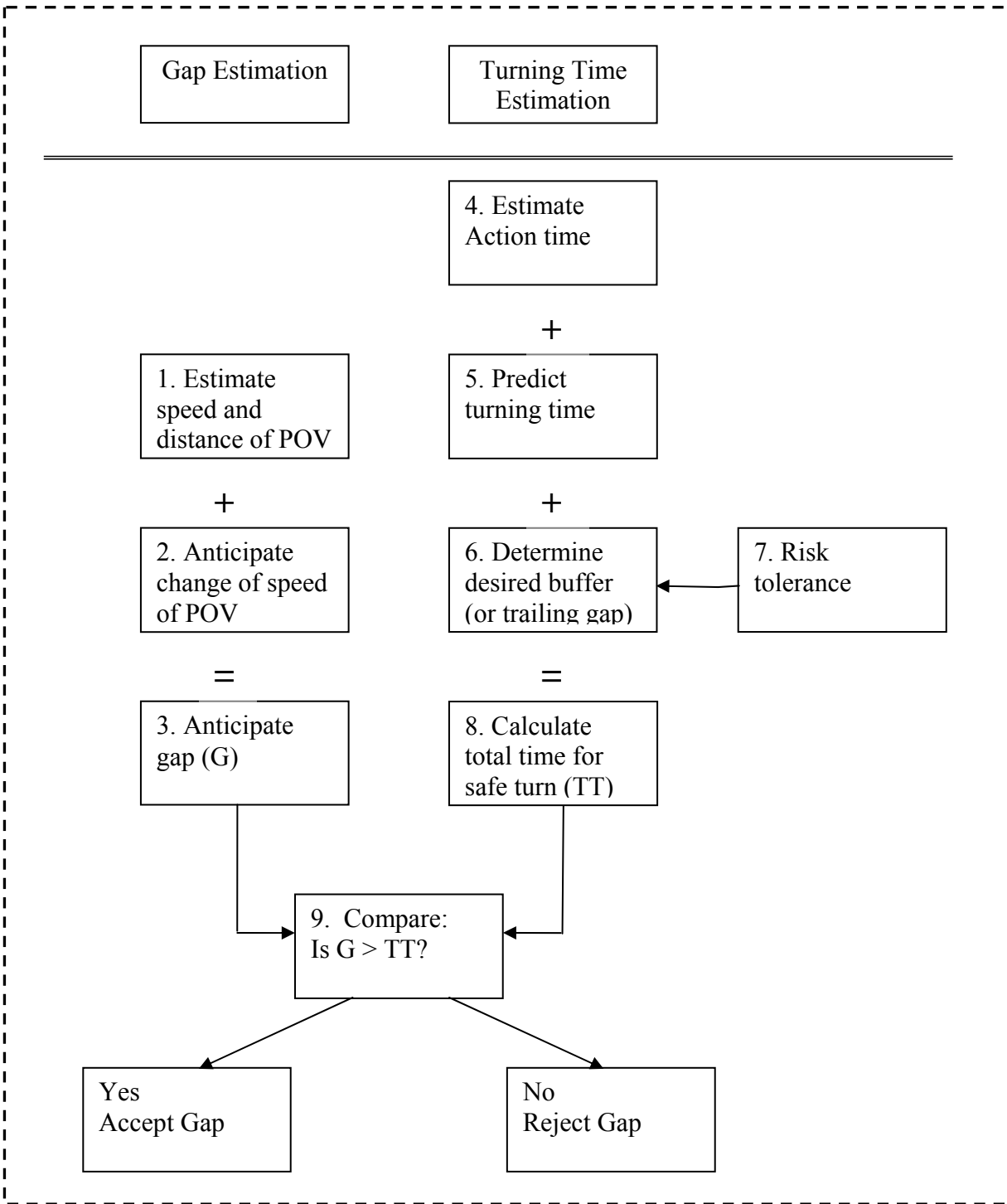

Figure 4.1 Model of SV Driver Process for Choosing a Gap

It is not certain how the SV driver “samples” information and makes judgments, but it is assumed that the process takes place in an iterative fashion. In Figure 1 and in the discussion below, the terms “estimate” and “calculate” are used to describe steps in the SV driver’s decision

process. It is assumed that the SV driver makes qualitative judgments about these variables, and not “quantitative” estimates or calculations. The IDS system is meant to support the driver decision process—the potential role of the IDS system is given in bold for each step in the decision process.

4.3.1.1 *Estimated Gap*

#1. Estimate speed/distance of the POV from the intersection

We presume that SV drivers make an assessment of the speed and distance of the POV from the point of conflict in the intersection. It is not certain how well the SV driver can make this assessment. It is probable that accuracy decreases with increased distance from the intersection, and inattention or limited visibility would degrade the process.

Potential role of IDS: The primary potential gain from IDS is providing greater accuracy in estimates of the speed/distance of the POV from the point of conflict. This gain is especially valuable if there are sight restrictions or if the driver is inattentive. However, in practical terms, there are limitations. Estimates based on radar may include error and radar may have trouble tracking vehicles. Devices such as loop detectors can only estimate speed of objects at fixed distances. Critical tasks for IDS research include:

- **Determining accuracy of current methods for speed/distance estimation**
- **Evaluating impact of error on the system**
- **Devising ways to improve estimation**

#2. Judgment about possible change in POV speed

At any particular moment in time, (i.e., any particular “iteration” in the SV driver’s decision process), future movement of the POV cannot be projected solely from current speed and position, and past trajectory. Therefore, the SV driver must anticipate subsequent changes in POV speed. It is likely that SV drivers have expectations about whether a POV will change speed based on past experience.

Potential role for IDS: Even a perfect IDS system could not predict future POV movement based solely on current speed and position and past trajectory. Therefore, to some degree, it must rely on historical data about the projected trajectory of the POV subsequent to any particular moment. Estimates of such changes can only be derived from data collection and analyses of POV vehicles. Task for IDS research include:

- **Determine to what degree, at any particular moment, subsequent POV behavior be predicted based on current speed/position and past trajectory;**
- **Determine to what degree historic patterns of movement at a particular intersection enhance prediction;**
- **If prediction can be improved, then devise ways to economically collect historic data and incorporate it into predicted POV movement;**
- **Evaluate impact of error on the system.**

#3. Predicted gap

It is presumed that the SV driver takes into account information from “1” and “2” to develop an expectation about the POV’s time of arrival (i.e., an expected gap). Not much is known about the accuracy of SV drivers in making such predictions. There are two sources of uncertainty: one is the SV driver’s estimate, and the other is the inherent variability in POV behavior that can only be predicted statistically.

Potential role for IDS: One function of the IDS system is to combine data from steps “1” and “2” above to make a prediction about the gap (i.e., time to arrival of the POV). Is it assumed that the IDS system can provide an estimate that is both (i) more accurate than that generated by the SV driver, and (ii) more reliable in the sense that it is not affected by limited line of sight or inattention. However, an estimate generated by IDS is subject to errors in both steps 1 and 2. Tasks for IDS research include:

- **Quantify errors in prediction**
- **Evaluate the impact of error on the system**
- **Develop ways to improve prediction**

4.3.1.2 *Estimated Total Turning Time*

#4. Action time (AT)

Action time (AT) is the time it takes the SV driver to start turning after "accepting" the gap. This could be measured as the time taken for the driver to move their foot from the brake pedal to the accelerator peddle. Research on driver action times shows a variation among drivers (Archer, 2000).¹⁵

Potential role for IDS: It will not be possible for the IDS system to differentiate SV drivers with respect to this variable and it will be necessary to assume a distribution based on previous studies of action time. Therefore, the contribution of IDS in accounting for this variable will be limited. Tasks for IDS research include:

- **Determine the impact of variability in action time on the system.**

#5. Predicted turning time

Turning time (TT) is the time it takes for the SV to complete the turn, and it is measured from the time the SV starts to make a completed turn to the time that the SV completes the turn, defined as clearing the path of the POV. Our analyses indicate that turning time varies substantially within a particular intersection and by type of turn. There is also considerable individual variability within intersection and type of turn. It is presumed that the SV drivers have some sense of how long they will need to take to make a complete turn.

Potential role for IDS: There is substantial variability among SV drivers in turning time. Since turning time varies by type of turn, it may be possible for IDS to make some adjustments based on detection of the type of turn. However, there is substantial variation in turning time even within the type of turn. It is unlikely that individual SV drivers can be differentiated based on turning time within each category of turn. Therefore, the role of IDS in accounting for SV turning time will probably be limited. Tasks for IDS research include:

- **Evaluating how accurately turning time can be estimated by detection, knowledge of signal time, and historic data;**
- **Determining impact of turning time variability on the system.**

#6. Desired buffer or “trailing gap”

The buffer (B) is the time between the end of the turn (defined in #5) and the arrival of the POV across the path of the SV. The level of risk can then be defined in terms of buffer size. A large buffer allows for wide variation in SV or POV movement. A small buffer means that even a small variation in SV movement (specifically, a delay in turning time) or POV movement (specifically, acceleration) could result in a collision. The buffer is derived roughly in the present study by subtracting an SV’s turning time from duration of the accepted gap. The buffer is found to vary widely among SV drivers.

Potential role for IDS: The desired buffer or “trailing gap” will vary for different SV drivers, and might vary across various conditions at the intersection (e.g., speed, gap availability). Although differences in the distribution of the buffer or trailing gap might be accounted for across intersections or traffic conditions, it is likely that preferred buffer times will differ across SV drivers even controlling for intersection characteristics. It is unlikely that such individual differences can be detected by the IDS system and used to differentiate drivers. Therefore, it will likely be necessary to use statistical distributions of buffer times to calibrate IDS algorithms. Tasks for IDS research are:

- **Identify demographic (e.g., age, gender) and other characteristics that might influence preference for a longer or shorter buffer;**
- **Determine how variation in preferred buffer or trailing gap impacts on the system.**

#7. Risk tolerance

It is presumed that the desired buffer depends partially on the level of cautiousness of the SV driver, possibly related to level of risk tolerance. This in turn likely depends on characteristics of the driver (e.g., age, gender) as well as situational characteristics (e.g., is the driver in a hurry). Although risk tolerance will contribute to variation in the buffer, it cannot be measured directly. The only information on this variable is inferred through the distribution of actual buffers.

Potential role for IDS: This is an inferred SV driver construct based on the observation that preferred buffers vary. Since various risky driving behavior (e.g., speed, headways) varies by age and gender, it is presumed that these same variables might predict risk taking with respect to gap selection. These variables will most likely to be accessible to an infrastructure-based IDS system. Tasks for IDS research are:

- **Identify demographic and other characteristics that might influence risk taking**
- **Determine how variation in risk taking may impact the system**

#8. Total turning time needed

It is presumed that, for the SV driver, the total time perceived to be needed for a safe and comfortable turn will be a qualitative judgment accounting for action time, turning time, and buffer. It is presumed also that SV drivers differ in their capacity to make this judgment.

Potential role for IDS: The three major inputs to this calculation (action time, turning time, and buffer) are at present only partially accessible to an IDS system, and probably will take the form of typical distributions gained through observation or other studies. However, anticipated total turning time is a crucial element in the subsequent step of deciding whether to turn. Tasks for IDS research are:

- **Establish how closely typical distributions reflect individual SV driver behavior**
- **Determine how variation in turning time impacts the system**

#9. Decision to turn or not

It is assumed that the SV driver in effect compares the anticipated gap (#3) with the total turning time needed (#8) and makes a decision whether to turn or not. If the gap is perceived as adequate (i.e., “#3” > “#8”), then the driver will make a turn. If the gap is not perceived as adequate (i.e., “#3” < “#8”), then the driver will not make a turn. The SV driver will go through this process for each approaching POV until the anticipated gap is perceived to be greater than the total turning time needed, at which time a turn will be made.

Potential role of IDS: In the steps of the decision process from #1 through #8, the strength of the IDS system is in gathering information about the POV movement so that it can be

compared to anticipated SV movement in turning left. However, providing (or not providing) the alert is the most critical step in the IDS process, and this depends on the logic of the system. There are two primary ways in which the IDS system can operate. One is through mirroring usual SV driver behavior, i.e., by providing a warning under roughly the same conditions that would trigger alarm in the driver, assuming adequate information and attention. The second way is through actually shaping the SV driver's behavior by attempting to alter the pattern of accepted and rejected gaps through programming of the warning algorithm.

In either case, the algorithm should be defined based on knowledge of the SV turning times, expected arrival of the POV, and SV driver gap acceptance patterns. For example, one approach is to warn about gaps that would be unacceptable to the largest number of drivers. In this case, we would choose to warn for a combination of (i) unusually long turning times on the part of the SV and (ii) unusually fast POV approach times (i.e., unusually short expected time to intersection). At present, very little is known about driver reaction to various different alerts. Tasks for IDS research are:

- Determine SV driver reaction to different levels of warning
- Design algorithms that provide an optimal balance of SV driver reactions

4.4 Methods

4.4.1 *Characteristics of Intersections*

Observations took place at five California intersections located in the cities of Berkeley (two intersections), Pinole, Burlingame, and San Francisco. The intersections were purposely chosen to differ on characteristics that might affect SV and POV behavior, and they varied in terms of being urban or suburban, the presence of pedestrians, cycle length, presence or absence of a left-turn pocket, traffic volume, and general speed levels, as summarized in Table 4-1.

Table 4-1 Intersection and Traffic Characteristics of Field Observations Sites

Intersection Location	Urban/Suburban	Pedestrian Presence	Signalized/NS (Cycle Length)	Intersection Size	Left-Turn Pocket for SV	Traffic Volume/Prevailing POV speed	Total Number of Gaps Observed
Alameda/Marin Berkeley 5/13/2004 (121 min)	Urban	No	Signalized (65 sec)	Large	No	Light (30)	336
Brannan/Fifth San Francisco 10/14/2004 (157 min)	Urban	Few	Signalized (60 sec)	Medium	No	Medium (25-35)	125
El Camino/Chapin Burlingame 9/28/2004 (159 min)	Suburban	Few	Signalized (80 sec)	Medium	No	Heavy (35-40)	263
Hearst/Shattuck Berkeley 10/2/2003 12/11/2003 (202 min)	Urban	Many	Signalized (75 sec)	Medium	Yes	Light (25)	109
San Pablo Ave/ Pinole 8/02/2004 (108 min)	Suburban	Few	Not Signalized	Small	Yes	Medium (40)	72

For these five intersections, a total of 161 collisions were indicated from Police Collision Reports¹⁶ (Table 4.2) from 1999 to 2003. A total of 50 were LTAP-OD collisions, 19 were other crossing-path collisions, and 92 were other (e.g., rear-end, side-swipe, etc.).

Table 4-2 Police reported collisions at five intersections from 1999 to 2003 by type of collisions (LTAP-OD, other crossing path, and other)

	Alameda/ Marin		Brannan/ Fifth		El Camino Real/ Chapin		Hearst/ Shattuck		San Pablo/ Pinole		Total	
	n	%	n	%	n	%	n	%	n	%	N	%
LTAP-OD	15	41.7	12	25.0	13	38.2	8	23.5	2	22.2	50	31.1
Other Crossing Path	8	22.2	4	8.3	2	5.9	5	14.7	0	0.0	19	11.8
Other	13	36.1	32	66.7	19	55.9	21	61.8	7	77.8	92	57.1
Total	36	100. 0	48	100. 0	34	100. 0	34	100. 0	9	100. 0	16 1	100. 0

The first intersection is located in the downtown area of Berkeley at Shattuck Avenue (which runs north-south) and Hearst Avenue (which runs east-west). Both streets have two lanes and a left-turn pocket in both directions. This intersection is signalized and includes pedestrian signals for all crosswalks. Observations focused on vehicles proceeding north on Shattuck and turning left onto Hearst, confronting southbound traffic on Shattuck. This intersection was characterized by fairly heavy pedestrian traffic.

The second intersection is located in the north area of Berkeley at The Alameda Avenue (which runs north-south) and Marin Avenue (which runs east-west). Both streets have two lanes of mainline traffic and no left-turn pockets. Observations were collected on traffic flowing northward on The Alameda and turning left onto Marin. A high percentage of northbound vehicles made this left turn, and there was relatively light oncoming traffic.

The third intersection was located in the City of Pinole on San Pablo Avenue, which runs northeast-southwest. Left turns were recorded for vehicles proceeding in a northeast direction and turning to enter a mini-mall parking lot. San Pablo has two lanes of mainline traffic for each direction with a single-lane left-turn pocket for vehicles entering the mini-mall parking lot. While traffic on San Pablo is not controlled at this intersection, traffic leaving the parking lot is controlled by a stop sign. Observations were collected for the southbound traffic on San Pablo

making left turns into the mini-mall. This intersection was characterized by the light presence of pedestrians and relatively high-speed oncoming traffic.

The fourth intersection is located in the southeast area of Burlingame at El Camino Real (northwest-southeast) and Chapin Avenues (northeast-southwest). Both streets have two lanes of mainline traffic, and there are no left-turn pockets on El Camino Real. Observations were made on vehicles traveling in the northwest direction and turning left onto Chapin. This turn is characterized by relatively heavy high-speed oncoming traffic.

The fifth intersection is located in the downtown area of San Francisco at Brannan Street (which runs northeast-southwest) and Fifth Street (which runs southeast-northwest). Both streets have two lanes of mainline traffic in each direction, and vehicles turn left without any left-turn pocket. Observations were made on traffic traveling northwest on Fifth and turning left onto Brannan. This intersection is in a highly urban location with a high proportion of oncoming vehicles traveling southeast on Fifth and then making right turns onto Brannan, which partially conflict with SV left turns from Fifth onto Brannan.

4.4.2 Video Data Collection and Analysis

For field observations, we set up cameras in a configuration shown in Figure 5.2. For some of the intersections only one camera was used, but it was able to record relevant turning movements.

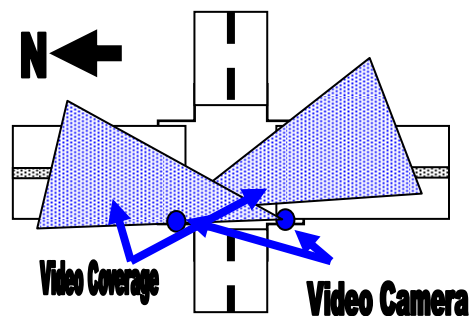

Figure 4.2 Video Data Collection Fields

To observe the SV and POV movements, and to determine the accepted and rejected gaps as well as the turning times, we utilized a video “playback” tool developed by PATH. A snapshot is shown in Figure 4.2, which can be operated from a QuickTime video application under the MS-Windows operating system. With this tool, the user is able to modify the playback speed of the video and mark the times when very specific events of interest occur.

To provide a consistent way of describing SV movements in the left-turn trajectories, a grid of points was generated over the geometric layout of the subject intersection (Figure 4.3).

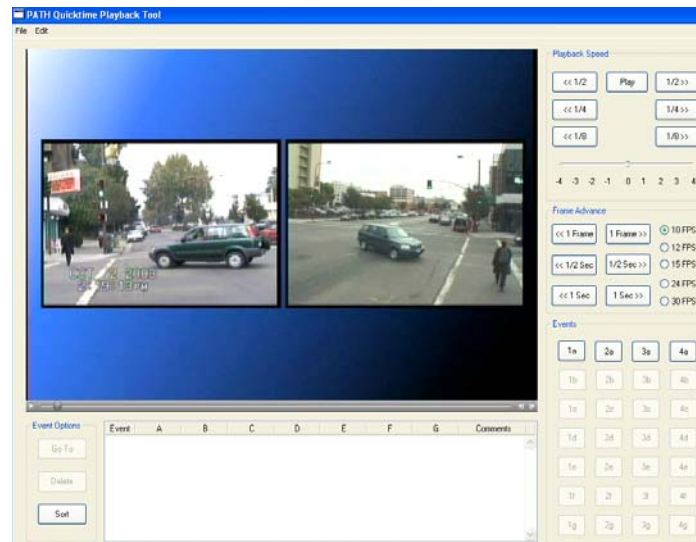

Figure 4.3 Screen shot of video data analysis tool of view

Definitions have been developed for vehicle movements at intersections^{17,18} We will use the following definitions derived from these sources:

Gap¹⁹

A “gap” is defined as time between two consecutive POVs (from the rear bumper of the first POV to the front bumper of the following POV) at the time when the SV can be reasonably assumed to be ready to initiate the turning maneuver, as illustrated in Figure 4.4.

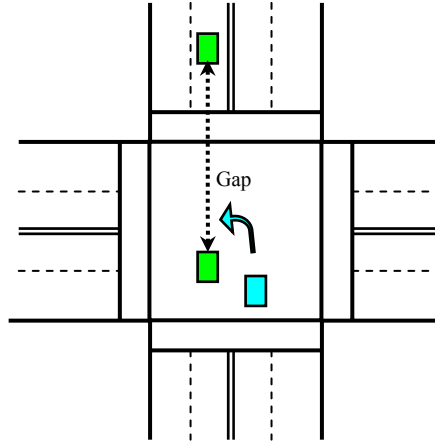

Figure 4.4 Arrow indicating the gap between two consecutive POVs

Turning Time

Turning time is the period that passes between the moment when the SV shows a significant initial left-turn movement and the moment when its rear bumper leaves the path of the oncoming POV (points 4 to 6 of Fig. 4.5).

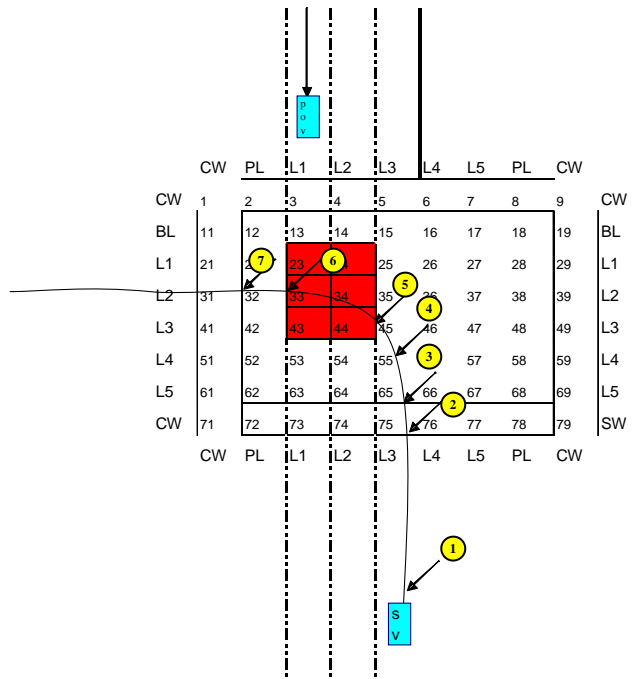

Figure 4.5 Arrows indicating points in the turning path of the SV at an intersection

4.4.3 Breakdown of Observations

With the video analysis tool, we observed a total of 1,573 unique gaps available to a total of 905 SVs over the five intersections (Table 3). Of these, 905 were "accepted" gaps, which occurred because 905 SVs each eventually accepted one and only one gap. From the video, we selected only those gaps that were 12 seconds or less since: (i) no gaps above 12 seconds were rejected (i.e., the relative length of gaps above 12 seconds was not relevant to SV drivers); and (ii) the distribution of gaps at the upper end was somewhat undefined since in some instances a POV was not in sight, or was at such a distance that it would not possibly have an impact on the SV driver. Of 905 accepted gaps, 165 (18.2%) were 12 seconds or shorter. Of 668 rejected gaps, all were 12 seconds or below, since no gaps larger than 12 seconds were rejected.

Table 4-3 Gap lengths observed (accepted and rejected) at five intersections (N=1573)

Intersection	Accepted Gaps			Rejected Gaps			Overall Total
	<=12*	>12**	Total	<=12	>12***	Total	
Alameda/Marin Berkeley	12	324	336	39	0	39	375
Brannan/Fifth San Francisco	7	118	125	117	0	117	242
El Camino/Chapin Burlingame	88	175	263	416	0	416	679
Hearst/Shattuck Berkeley	44	65	109	45	0	45	154
San Pablo Ave/ Pinole	14	58	72	51	0	51	123
Total	165	740	905	668	0	668	1573

*Turning time and gap size recorded

**Turning time was recorded, not gap size—in many cases gap size over 12 seconds was indeterminate because no POV was in sight.

***There were no rejected gaps over 12 seconds

4.4.4 *Types of Analysis*

We conducted three different types of analyses with these data.

The first type of analysis focused on the distribution of gap acceptance and gap rejection in the 833 instances where the gap confronting the SV driver was 12 seconds or less (165 accepted gaps and 668 rejected gaps). We set 12 seconds as a cutoff because (i) there were no rejected gaps above 10 seconds in the first intersection studied (Hearst and Shattuck), and we allowed two more seconds in subsequent observations in case there were rejected gaps above 10 seconds); and (ii) above 12 seconds, the size of the gap didn't appear to make a difference to the SV driver, and in many cases, gaps were indeterminate because a POV was not in sight. This analysis allowed us to see:

- The distribution of available gaps at each intersection. We expect intersections with heavier oncoming traffic volume to have a higher percentage of small gaps that should make left-hand turns more difficult for SVs.
- The percent of gaps accepted as a function of gap length. We expect that the probability of a gap being accepted will increase with length of gap, but that the SV driver's decision will also depend on other factors, such as the availability of gaps, the speed of traffic, and the perceived time it takes to make a turn.

The second type of analysis focused on characteristics of turns made in the 905 instances when gaps were accepted, whatever the length of the gap. This analysis included both type of turn and time taken to complete the turn. This analysis will allow us to see the distribution of turning times by type of turn and gap length.

4.5 Results

4.5.1 Distribution of gaps presented to the SV driver

4.5.1.1 Basic results

A total of 1,573 gaps were observed across the five intersections (Table 5.3), but gap lengths were obtained only for those 12 seconds and below. The distribution of these 833 measured gaps 12 seconds and below for all intersections combined show that the most frequent (modal) gap was 2 seconds²⁰ (almost 30 percent of gaps analyzed), followed by gaps of 3 seconds (about 18 percent) and four seconds (about 12 percent) (Figure 5.6). The majority (69 percent) of gaps were 4 seconds and shorter.

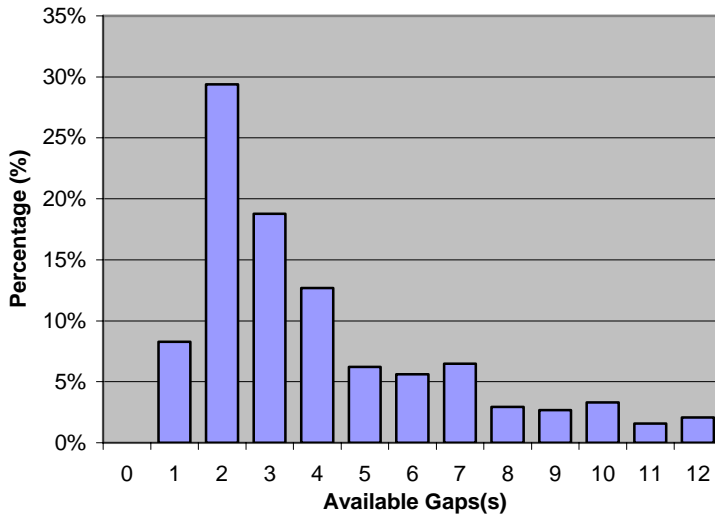

Figure 4.6 Distribution gaps of 12 seconds or less for all intersections combined (n=833).

The general shape of the distribution of gaps was similar across all five intersections; that is, with a higher percentage of gaps between one and four seconds and a long tail to the right (unmeasured above 12 seconds). Otherwise, however, the distribution of gaps presented to the SV driver varied considerably across the five intersections (Figure 4.7).

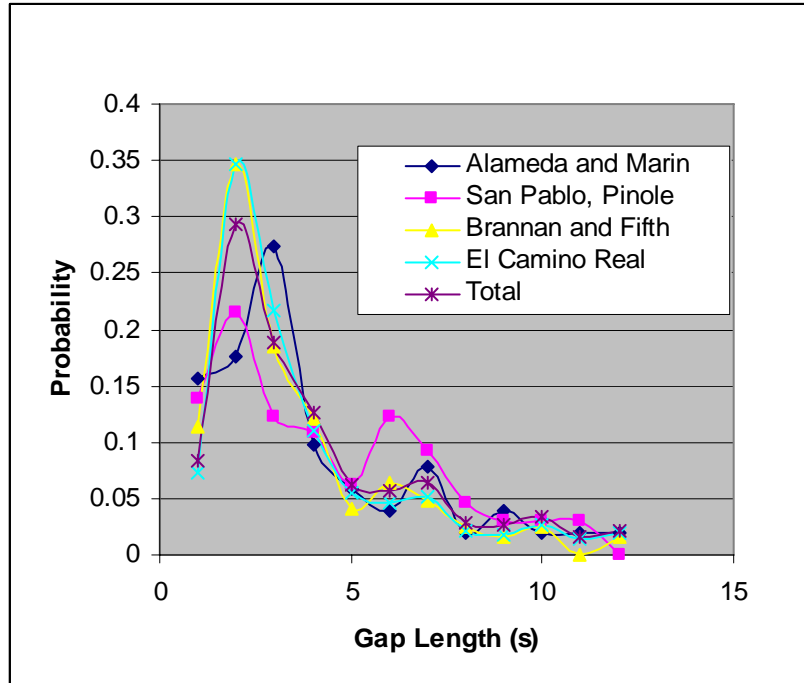

Figure 4.7 Distribution gaps of 12 seconds or less for individual intersections (n=833).

One way of illustrating the difference in distributions of gaps across intersections is the percentage of gaps 12 seconds or below (Table 4.4). A high percentage of such gaps would reflect generally shorter gap times. One intersection, Alameda/Marin, had a particularly low percentage of gaps below 12 seconds, about 14 percent. This is consistent with the observation that there were relatively few oncoming vehicles (POVs) at this intersection. Another intersection, El Camino, had a particularly high number of gaps below 12 seconds, at about 74 percent. This is consistent with the observation that El Camino Real/Chapin had a very high traffic volume. The other three intersections had percentages of gaps below 12 seconds of between 50 and 60 percent. The results for the distribution of gap lengths for those 12 seconds and below as well as the percentage of gaps 12 seconds and below out of the total set of gaps both indicate a fairly high variability in the distribution of gaps across intersections.

Table 4-4 Percentage of gaps 12 seconds or below

Intersection	Total number of gaps observed	Percentage 12 seconds or below (%)
Alameda/Marin	242	13.6
Brannan/Fifth	679	51.2
El Camino Real/and Chapin	154	74.2
Hearst/Shattuck	375	57.8
San Pablo Ave/Pinole	123	52.8
All Intersections	1,573	53.0

Implications for IDS

At a given intersection, *longer* average gap lengths will mean that an SV driver will find it easier to find an adequate gap. However, longer gap times could also lead an SV driver to have a lower expectation that a POV will appear. A *shorter* average gap will mean that the SV driver will find it more difficult to find an adequate gap. In this circumstance, the SV driver may be more likely to choose an inadequate gap (especially if the delay led to impatience) or may accelerate more quickly than normal through the turn. Further work is needed to whether the distribution of gap lengths affect driver behavior, and if so, how much.

The distribution of gap lengths will generally vary with traffic volume, speed, and degree to which vehicles are platooning.²¹ If the distribution of gap times is found to impact SV driver behavior, then further work is needed to determine how the distribution of gap length may vary by these and other variables.

4.5.1.2 Gaps presented to the SV driver as a log-normal distribution

The distribution of gaps presented to the driver can be described by a log-normal function, defined as: “a [continuous distribution](#) in which the [logarithm](#) of a variable has a [normal distribution](#).²²” Three parameters describe the log-normal distribution: (i) amplitude, (ii) center (measure of central tendency), and (iii) width (measure of dispersion). Tests of fit indicate a good fit for four of the individual intersections except Hearst and Shattuck²³ and for the four intersections combined. For the intersections combined, the fitted values look close to the actual values (Figure 4.8) and the statistics show an excellent fit.

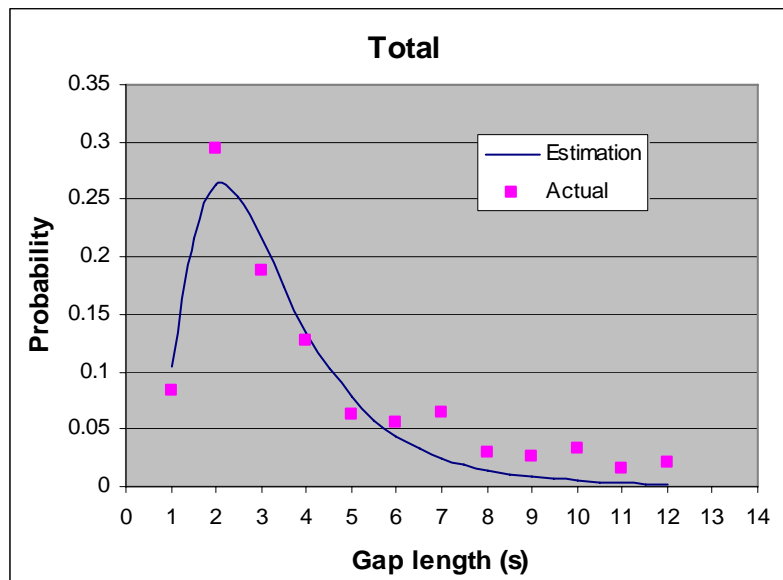

Figure 4.8 Log-normal function fitted to distribution of gaps presented to the SV driver, for all intersections combined

The closeness of fit to the function suggests that several parameters can be used to describe differences in gaps presented to SV drivers across different intersections and over time. The size of gaps over 12 seconds was not measured, i.e., the distribution is truncated on the upper end, but this did not hinder the goodness of fit. It is likely that these gaps are of less relevance to the SV driver and may be irrelevant for studies of gap acceptance. The gaps at one intersection, Hearst/Shattuck, didn't fit the log-normal distribution. This was the first intersection analyzed, and observations below the minimum gap accepted were not measured.

Gap distribution is affected by both POV volume and platooning. This in turn could be affected by adjacent traffic signals or other features that impact clustering. Platooning could lead to a distribution with lots of relatively small gaps and then an extended tail of long gaps. Therefore, observations at intersections, or times of the day, with less platooning might yield a different distribution.

Implications for IDS

Being able to describe the distribution of gaps presented to the SV driver has several possible uses:

- Allow characterizing different intersections or different times of the day with a few parameters;
- Used in simulation models to present different patterns of gaps to the SV driver by varying parameters of the model;
- Facilitates use of statistical models to identify factors that lead to gap acceptance.

4.5.2 Gap acceptance curves

4.5.2.1 Basic results

We hypothesized that the probability of a gap being accepted would increase with gap length, and that the relationship between gap length and gap acceptance might vary across intersections. We calculated the probability that a gap would be accepted among all 833 gaps below 12 seconds for all intersections and for the intersections combined. We aggregated into one-second intervals. For some intersections there were fairly small numbers for some of the time intervals. Therefore, we calculated a three-point running average to smooth the data.

Across all intersections, all gaps were rejected (i.e., none were accepted) below 3 seconds, and all gaps were accepted above 10 seconds, leaving a range between 3 and 10 seconds when some but not all gaps were accepted. For the combined gaps from all intersections, the probability that a gap was accepted increased in a step-wise fashion from 3 to 10 seconds (curve label “Total” in Figure 4.7), generating a “gap acceptance curve²⁴.” By interpolation, we calculated the gap lengths at which the gap acceptance rate was 15, 50, and 85 percent (Table 5.5). For all

intersections combined, these gap lengths were 4.2 seconds, 6.3 seconds, and 9.6 seconds respectively.

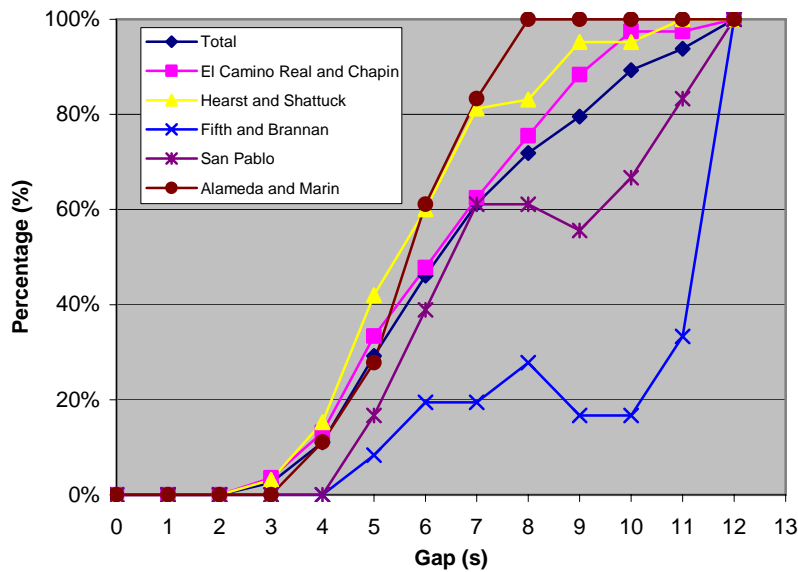

Figure 4.9 Percent of gaps accepted by gap length.

The general pattern was similar for *individual* intersections (Figure 4.9 and Table 4.5). For each intersection there was a more-or-less stepwise increase in the probability that a gap would be accepted with increases in gap length, although, due to small numbers for most of the gap lengths, the gap acceptance curve for individual intersections was somewhat uneven. The position and shape of the gap acceptance curves varied across intersections. One measure of this is the range between those gap lengths that are all rejected and those that are all accepted. For example, all gaps less or equal to 3 seconds were rejected at Hearst and Shattuck and at El Camino Real. Alameda/Marin rejected all gaps less or equal to 4 seconds, and all gaps less or equal to 5 seconds were rejected at Brannan/Fifth and at San Pablo Ave./Pinole. Another measure of the difference between intersections is the point at which 15, 50, or 85 percent of gaps are accepted. For example, the gap length at which 85 percent of the gaps were accepted was relatively high for two intersections, Brannan and 5th and San Pablo, or 11.8 and 11.1 seconds, respectively. This shows that the gap acceptance curves were somewhat higher for Brannan and 5th for and for San Pablo, indicating that drivers were less likely to choose shorter gaps and more like to choose longer gaps at these intersections.

Table 4-5 Statistics for gap acceptance curves by intersection and for all intersections combined

Intersection	Gap lengths in seconds (interpolated) at which 15, 50, and 85 percent of gaps are accepted			Parameters of logistic model describing the gap acceptance curve (See next section)	
	15%	50%	85%	Point of 50 percent gap acceptance	Slope
Alameda/Marin	4.2 sec	5.7 sec	7.1 sec	5.7	0.59
Brannan/Fifth	5.6 sec	11.3 sec	11.8 sec	*	*
San Pablo/Pinole	4.9 sec	6.5 sec	11.1 sec	7.6	0.23
Hearst and Shattuck	4.0 sec	5.4 sec	8.2 sec	5.6	0.41
El Camino Real/Chapin	4.1 sec	6.2 sec	8.7 sec	6.2	0.33
All intersections	4.2 sec	6.3 sec	9.6 sec	6.5	0.30

*Estimate unstable

Implication for IDS

In the vast majority of cases, SV drivers chose an appropriate and safe gap for their left turns. It has been suggested that one strategy for designing an IDS warning system is to mirror the usual behavior of SV drivers²⁵. Following this suggestion, a warning would be given for gaps that a driver would usually reject, and not be given for gaps that a driver would usually accept. Presumably, this would be helpful if the SV driver were inattentive and/or had blocked visibility. Therefore, the IDS would support SV drivers in making decisions that drivers would ordinarily make if they were attentive and had adequate information.

Our observations show that SV drivers may vary considerably in their preferences about what constitutes an acceptable gap; in the present set of observations, an acceptable gap ranged from 3 to 12 seconds. Yet, at a particular intersection there is no way beforehand to distinguish drivers

who are likely to accept a shorter or longer gap. This makes it difficult for the IDS system to “mirror” driver behavior, and the IDS algorithm is forced to adopt a "one-size-fits-all" approach.

If a fixed gap size must be chosen as the basis for designing a warning in a particular situation, its relevance or significance will vary for different drivers. On one hand, we might choose a gap length (for convenience, called here a “target gap”) with a *high* probability of being rejected normally by most SV drivers (i.e., a fairly small gap). The warning would be given for the range defined by this particular gap and all smaller gaps (gaps \leq target gap). This means that many gaps *above* this range would also be rejected by many SV drivers. This discrepancy may have two consequences: (i) it may lead the some SV drivers to conclude that the warning is inadequate (i.e., that a warning is not given for many gaps they would have rejected) and/or (ii) it may lead some SV drivers to think that a gap is okay that they would have otherwise rejected. The SV driver may learn (perhaps correctly) not to trust the system.

On the other hand, we might consider a gap length with a *low* probability of being rejected by most SV drivers. In this case there will be many gaps *below* that point that would have been accepted by many SV drivers (i.e., a fairly large gap). The discrepancy would operate in the opposite direction of that above. In this case many SV drivers might think that they could have easily proceeded when an alert was given. Many drivers might learn to ignore the alerts and/or experience the warning as a “nuisance.” A possible consequence is that alerts given in the event of a truly dangerous situation may be ignored.

An important concept is that of the discrepancy between the target gap length, i.e., the gap defining the warning, and the largest gap ordinarily rejected by a particular SV driver. This discrepancy will differ across drivers, and in theory can be quantified. If the target gap is fairly small and the largest gap length ordinarily accepted by a particular SV driver is just one second or so greater than the target gap, then the discrepancy will be fairly small and in the positive direction (the sign of the discrepancy here is arbitrary—if “discrepancy” is equal to preferred maximum gap rejected minus target gap the “discrepancy” will be positive when the preferred maximum gap is larger than the target minimum gap). If the maximum preferred gap of a

particular SV driver is much larger than the target gap, then the discrepancy will be large. And so forth.

There are two critical research questions: One is to evaluate actual driver reactions to warnings based on different target gaps. A reasonable, and testable, hypothesis is that the probability of reactions such as those suggested above is directly related to the size and direction of the discrepancy between the target and the preferred minimum gap.

The second critical, and related, question is to determine which consequences are the most important to avoid. A starting assumption is that the most serious error is to fail to warn in the case of a gap that is either dangerous or is perceived to be by the most conservative SV drivers. If this is true, then the warning must be generally conservative, i.e., given for all gaps that have even the minimal chance of rejection by SV drivers along with all other gaps with a greater change of rejection (i.e., the first option above). However, this must be balanced against the resulting increase warnings possibly experienced as “nuisance” warnings by some SV drivers. The balance between these two types “errors” depends on actual SV driver reactions. It is crucial to understand actual SV driver reaction to variation in the target gap length chosen for triggering the warning. This reaction is being studied by the Berkeley IDS team.

4.5.2.2 *Gap acceptance curves modeled by the logistic function*

The gap acceptance curves shown in Figure 4.9 closely resemble a logistic distribution often used to describe a dose-response function²⁶. A logistic function in its simplest form describes a continuous increasing function between 0 and 1 (or between 0 percent and 100 percent. Thus, the curve rises from 0 to 100 percent and is described by the following equation:

$$Y = \frac{100}{1 + 10^{(\log(Accept50) - X) \times Slope}}$$

This equation describes a symmetrical curve where Accept50 is the point (in seconds) at which the gap acceptance rate is 50 percent, and Slope is a measure of dispersion. We calculated the

Accept50 and Slope for all intersections combined and for each intersection separately. The variance of these estimates for Brannan/Fifth was very high, so we excluded Brannan/Fifth from this analysis. The lack of fit for this intersection may reflect sporadic patterns of traffic that included a large number of right-turning POVs. The results are given in the two right-hand columns of Table 5.5. Accept50 varies by over two seconds between the lowest (5.6 at Hearst and Shattuck) and highest (7.6 at San Pablo Ave./Pinole) intersections, and for each intersection is fairly close to the interpolated point at which 50 percent of the gaps were accepted (3rd column). The slope also varies substantially between the steepest (0.59 at Alameda/Marin) and the shallowest (0.23 at San Pablo Ave./Pinole). The gap acceptance curves modeled in this way are illustrated in Figure 4.10.

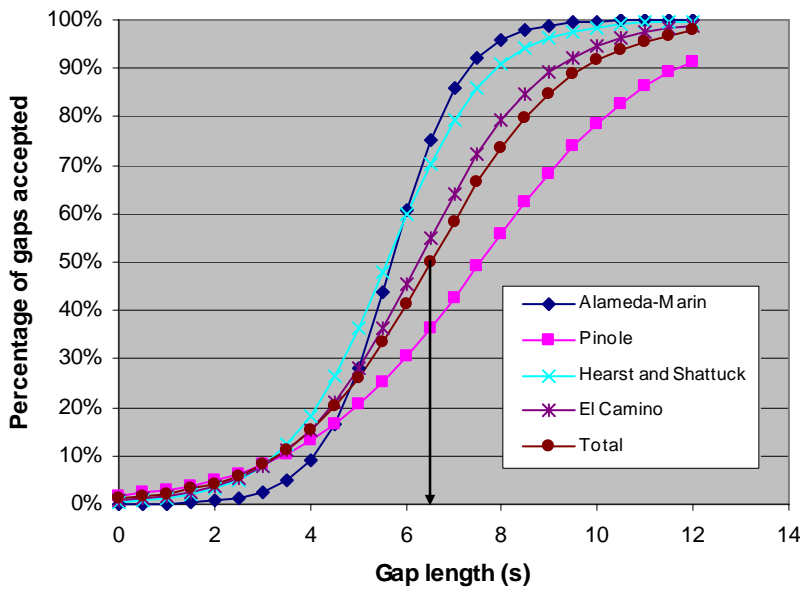

Figure 4.10 Logistic function describing the gap acceptance for all four intersections in the analysis. Arrow is Accept50 for curve representing the four intersections combined.

The comparison between the actual gap acceptance curve and the one calculated through the model is shown in Figure 4.11. We can see that the model is a good approximation of the actual curve.

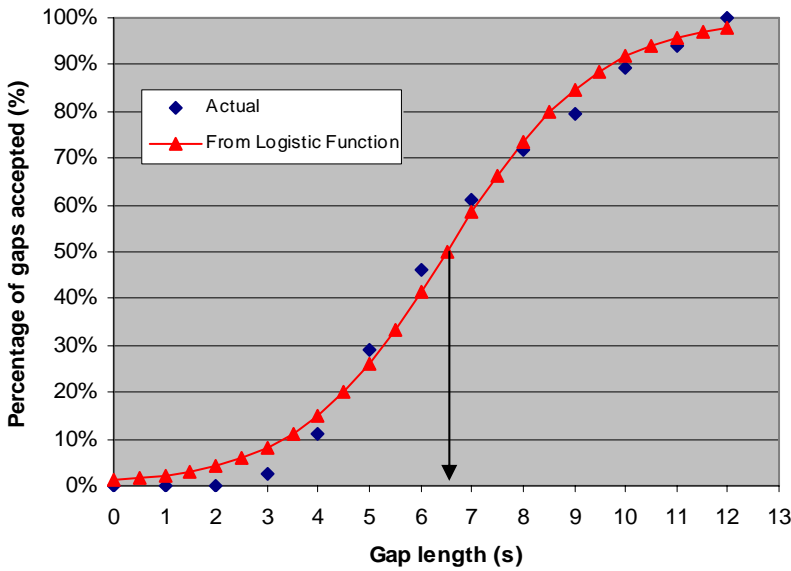

Figure 4.11 Actual vs. logistic function gap acceptance curve

Implications for IDS

Using a logistic model, left-turn approaches can be characterized in terms of two parameters: i) Accept50, reflecting position along the dimension of gap length and (ii) Slope, representing dispersion.

In general, these parameters have different implications for IDS algorithms. Differences in position along the dimension of gap length can be accommodated in IDS algorithms by simply adjusting the warning criterion to be shorter and longer, accordingly.

Differences in slope have stronger implications. A very high slope indicates a lower dispersion, meaning that drivers will generally have less variability. This means that there will be less discrepancy for any particular driver between any particular warning point and the driver's general preference. A shallower slope, or greater dispersion, will have just the opposite implication, i.e., in general there will be a greater discrepancy between the warning point and the driver's general tendency.

Given the potential value of being able to characterize gap acceptance curves with a two-variable function, further work is needed to determine the appropriateness of the logistic function under different conditions.

4.5.3 Turning time

4.5.3.1 By intersection

Our video observations have shown that there are unique distributions of turning times for individual intersections. There are three main findings that we will discuss separately: (i) turning times vary *across* intersections; (ii) turning times vary *within* intersections; (iii) turning times vary by type of turn, and this accounts for some of the differences *across* and *within* intersections.

The distribution of turning times varied substantially across different intersections. This is shown graphically (Figure 4.12) and statistically (Table 4.6). Alameda/Marin had the lowest turning times, with 70% of the turns at Alameda/Marin between 2 and 3 seconds and with a median turning time of 2.4 seconds. Brannan/Fifth had the highest turning times, with about 40-50% of the turns between 3-4 seconds and a median turning time of 4.0 seconds. The 15th and 85th percentiles show the same magnitude of difference. The difference between the 15th and the 85th percentile, an indication of variability, also varied considerably across intersections. For Alameda/Marin the difference between the 15th and 85th quartile was one second, but for Brannan/Fifth this value was 2.3 seconds. Higher medians were associated with higher variation.

Lower turning times and low variability at Alameda/Marin may be due to the fact that POV traffic was very light, SV speed was fairly fast, and there were few impediments to turning, such as pedestrians.

Higher turning times and a higher variability at Brannan/Fifth may have been due to oncoming POVs making a right-hand turn. During the period of observations, 37.6% of turns were made while an oncoming POV was making a right turn at the intersection. While the first POV was turning right, the SV started turning left and then waited in the second POV's path until the first

POV completed the movement. The average turning time for these cases was 4.9 seconds (with a standard deviation of 1.6 seconds) compared to 3.8 seconds (with a standard deviation of 0.8 seconds) for SVs making the same turn without a right-turning POV.

The above example suggests that characteristics of the intersections themselves and/or of traffic patterns may affect turning time. In addition to right-turning POVs, such differences might include: (i) intersection geometry, (ii) average speed of SVs at these intersections, and (iii) distribution of type of turn within an intersection. “Type of turn” will be discussed in a section below.

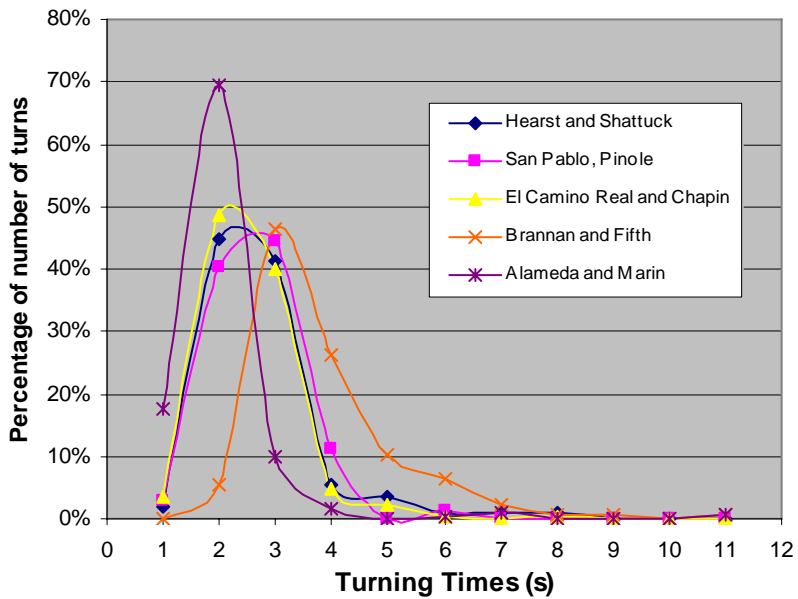

Figure 4.12 Distribution of Turning Time by Intersection

Table 4-6 SV turning time by intersection (n=905)*

Intersection	Total Number of Observations	Average (sec)	Standard Deviation (sec)	Median (sec)	15th Percentile	85th Percentile	Difference 85th-15th
Alameda/Marin	336	2.6	1.0	2.4	2.0	3.0	1.0
Brannan/Fifth	125	4.4	1.4	4.0	3.3	5.6	2.3
San Pablo Ave./Pinole	72	3.2	0.7	3.2	2.5	4.0	1.5
Hearst and Shattuck	109	3.3	1.0	3.1	2.5	3.8	1.3
El Camino Real/Chapin	263	3.1	0.8	3.0	2.5	3.8	1.3
All Intersections Combined							

* Time from first significant turning to clearing POV lane

Implications for IDS

A warning about an oncoming POV must be given to the SV driver at least just prior to the time when they can decide to proceed with the turn. Therefore, the turning time for a given intersection provides a minimum time for detection of the POV. A relatively longer turning time will require earlier detection or detection farther away from the intersection. For example, if the turning time is 5 seconds, then the POV must be detected at least 5 seconds before it is to arrive at the intersection. If the POV is traveling at 30 feet per second, then, the minimum distance from the intersection to detection is 150 feet ($30 \frac{ft}{sec} \times 5 \text{ sec}$). Points of minimum distance for required detection will vary by intersection.

4.5.3.2 Turning time within intersections

There was also considerable variation *within* each intersection, with a lower bound at about 1-2 seconds, a mode of about 2-3 seconds, and general skewness toward the upper end. A measure of variability, the difference between the 15th and the 85th percentile, ranged from 1 second (Alameda/Marin) to 2.3 seconds (Brennan and 5th). Higher variability was correlated with the median, and it is possible that factors related to the relative length of turns also impact the

variability of turns. The distribution of “Type of Turn” for each intersection may affect both the variability within intersections as well as the variability between intersections, and will be discussed in the next section.

Implications for IDS

A warning algorithm needs to account for as wide a range of turning times as possible for each particular intersection. It may be possible to differentiate vehicles by the type of turn (see below), but there is considerable variation in turning times even *within* each type of turn. Since being able to predict turning times within each type of turn is very unlikely, a single warning algorithm will need to apply to all SVs within a particular type of turn. Warnings that assume the longest (slowest) turns within each class of turns must be provided. One consequence of such warnings is that they may reduce system credibility for some SV drivers who are used to making faster turns, and these drivers may eventually ignore such warnings. This reaction is likely to be the most pronounced for drivers use to make the fastest turns. For most intersections, the difference between the 85th and the 15th percentiles is on the order of 1 to 2 seconds. Warning times must be given assuming the longest (or nearly the longest) turns, and these may be ignored by drivers who make shorter turns. The wide variation between slower and faster turns will exacerbate this problem. The variability can be reduced if the type of turn can be detected

4.5.3.3 Turning time by type of turn

Types of turns:

We identified the following distinct types of turns, defined by signal phase and traffic conditions:

- i) Pedestrian present Pedestrian is present in the destination crosswalk while the SV is turning left.
- ii) On the fly SV initiates and completes the left turn without stopping at any time.
- iii) From queue SV initiates the left turn from a queue at the intersection (i.e., SV is turning immediately after another SV).

- iv) Yellow or red Yellow or red indication while the SV is turning left but before completing the turn.

- v) Green light SV waits for an acceptable gap during the green light with no pedestrians present at the crosswalk and then SV initiates and completes the turn during the green phase.

A total of 905 SV turns were observed at the five intersections, and these were distributed among the five types listed above (Table 4.7). Turns on a green light with no pedestrians present were the most frequent turns (almost 43%) while turns with pedestrians present (about 4%) were the least frequent.

Table 4-7 Types of left turns in five intersections

Type of turn	Total	Percent
Pedestrian present	38	4.2%
On the fly	162	17.9%
From queue	192	21.2%
Yellow or red	206	22.8%
Green light*	387	42.8%
Overall	905	100.0%

*No pedestrian present

The distribution of types of turns varied by intersection (Appendix B). For example, the highest percent of turns that were “green light” turns (i.e., on a green light with no pedestrians present) were at San Pablo Ave./Pinole (60%) and El Camino Real (67%) compared to less than 40% for other intersections. Turns with “pedestrian-present” were highest at Hearst and Shattuck (20%) but much less frequent at other intersections. “Yellow-red” turns were highest at Brannan/Fifth (57%) but much less frequent (less than 30%) at other intersections. The high number of “yellow-red” turns at Brannan and 5th reflects the heavy oncoming traffic at that intersection that forces many vehicles to initiate and complete a turn during the amber or at the beginning of the red cycle.

4.5.3.4 Turning times

The lowest average turning time and the lowest median time for all intersections combined (Table 4.8) and for each separate intersection (Appendix B) was for “on the fly” turns. This is probably because “on the fly,” turns begin when the vehicle is already in motion, while other types of turns begin when vehicles are either stopped or slowly “creeping” forward. Turns “from queue,” “yellow or red,” and “other: waiting for gap during green with no pedestrian present” were all in the middle range between and average of 3.0 and 3.4 seconds.

Turning time was highest when pedestrians were present in the destination crosswalk (4.6 mean seconds) (Table 4.8), more than two seconds longer than any other type of turn. Turning time was higher with pedestrians present for all five intersections (Appendix B). SV drivers were frequently observed making a left turn and then waiting in or near the POV’s path until pedestrians cleared the destination crosswalk and then continued with the turn. It is not known whether drivers simply do not see the pedestrians before beginning the turn, or whether they see the pedestrians but begin the turn in any case, expecting to wait and perhaps expecting that if a POV approaches to the intersection it will slow down to provide time for the SV to complete the turn.

Table 4-8 SV turning times by type of left turn

Type of turn	Total Number of Observations	Average (Mean) Seconds	Standard Deviation (Seconds)	Median Seconds	15th Percentile (Seconds)	85th Percentile (Seconds)
Pedestrians	38	4.6	1.8	4.1	3.2	6.1
On the Fly	162	2.5	0.5	2.4	2.0	2.9
From Queue	192	3.0	0.9	2.7	2.2	3.9
Yellow or Red	206	3.4	1.3	3.1	2.3	4.2
Green Light*	387	3.1	0.9	3.0	2.4	3.8
Overall	905	3.1	1.1	2.9	2.2	4.0

*No pedestrians present

Implications for IDS

There are two implications for IDS. The first is the possibility of being able to anticipate the turn and then being able to adjust the warning to the type of turn. For example, the target gap for triggering a warning could be smaller for “on the fly” than for other turns. This of course depends on being able to detect the turn. Some information on type of turn, or turning time in general, can be gained from the single timing in conjunction with SV speed. The Berkeley SV team is exploring the feasibility of anticipating type of turn and turning time.

The second implication focuses on the substantially longer turns when pedestrians are present. We found substantially longer turns and longer variability in turns when pedestrians were present in the destination crosswalk. The average was more than one second longer than for turns in the yellow or red, the type of turn with the next slowest turns, and the standard deviation was much higher than for the other types of turns. Two solutions are suggested. For intersections with low pedestrian volume: provide a warning that indicates the presence of pedestrians whenever one is present in the crosswalk. For intersections with high pedestrian volume, provide a separate signal phase for pedestrians. Pedestrians present in the destination crosswalk present a unique challenge for LTAP-OD warning systems, and have impacts for pedestrian safety as well as the design of algorithms for prevention vehicle-vehicle collisions. **Further assessment of the impact of pedestrians on SV and POV movements is critical, and is being pursued by the Berkeley IDS team.**

4.6 Future Research

The results of this paper, and consideration of the implications for IDS alert systems, suggest two general areas of research.

The first area of research is to identify factors that influence gap acceptance for SV drivers in LTAP-OD scenarios. For example, the distribution of gap lengths varies substantially by intersections and within the same intersection as a function of traffic volume, speed, and degree to which vehicles are platooning, and it is important to know if this impacts gap acceptance

behavior. At a given intersection, *longer* average gap lengths will mean that an SV driver will find it easier to find an adequate gap. However, longer gap times could also lead an SV driver to have a lower expectation that a POV will appear. A *shorter* average gap will mean that the SV driver will find it more difficult to find an adequate gap. In this circumstance, the SV driver may be more likely to choose an inadequate gap (especially if the delay leads to impatience) or to accelerate more quickly than normal through the turn. Further work is needed to whether the distribution of gap lengths affects driver behavior and, if so, by how much. Other factors also may influence gap acceptance behavior by SV drivers, including time in the signal cycle, weather conditions, lighting, etc. The impact of these conditions on gap acceptance behavior needs to be studied in order to be able to calibrate IDS systems.

The area of research is the evaluation of actual driver reactions to warnings based on different target gaps. A reasonable, and testable, hypothesis is that the probability of reactions such as those suggested above is directly related to the size and direction of the discrepancy between the target and the preferred minimum gap. A related question is to determine which consequences are the most important to avoid. A starting assumption is that the most serious error is to fail to warn in the case of a gap that is either dangerous or is perceived to be by the most conservative SV drivers. If this is true, then the warning must be generally conservative, i.e., given for all gaps that have even the minimal chance of rejection by SV drivers along with all other gaps with a greater chance of rejection (i.e., the first option above). However, this must be balanced against the resulting increase warnings possibly experienced as “nuisance” warnings by some SV drivers. The balance between these two types “errors” depends on actual SV driver reactions. It is crucial to understand actual SV driver reaction to variation in the target gap length chosen for triggering the warning. This SV driver reaction is being studied by the Berkeley IDS team.

5 DII LABORATORY EXPERIMENTS FINAL REPORT

5.1 Background

The Driver-Infrastructure Interface, or DII, is an indispensable component of the IDS system, for it serves to notify the driver of the SV of a potential threat, as determined by the sensors and computer algorithms in the intersection infrastructure. Given the importance of the DII, considerable thought went into its design, fabrication, and testing. In the beginning stages of the project, a number of alternative designs were considered. The common element of all of these designs was a self-luminous display using arrays of active light-emitting devices, especially light-emitting diodes (LEDs), to convey the appropriate information to the driver. For a while we considered using a standard addressable variable message sign to convey an appropriate warning that a left turn was inadvisable. Some of these ideas involved text messages of various sorts such as “DANGER, ONCOMING TRAFFIC”. Others involved symbolic, graphical representations intended to convey the same message. Some designs included displays of numeric information such as the speed of an oncoming POV.

In any case, we wanted to create an active sign which would draw (I changed the mood here to the subjunctive, because at this point the sign is still theoretical. Either way is grammatical, though) attention only when activated, and would not be a distraction when quiescent. Furthermore, we wished to employ our considerable experience with MEWS devices (motion-enhanced warning signals) to create a design which incorporated flashing or apparent motion to increase the conspicuity of the device once activated.

After consideration of a multitude of alternative designs, we decided to produce an active, dynamic version of the standard MUTCD left-turn prohibition sign, designated R3-2, pictured below.



Figure 5.1 R3-2

We chose this concept because every driver is familiar with (the static version of) (why parentheses? I don't necessarily think the parenthetical information is optional here.)this sign, sometimes installed with secondary information such as hours or conditions when the left turn is prohibited. With this design, there would be no need for a driver to read text or to understand unfamiliar symbols. What remained was for us was to produce an attention-getting active device that presented a self-luminous, motion-enhanced version of this standard MUTCD sign.

It was decided that it would be best not to invert or substantially alter the color scheme of the standard sign so as to maintain maximum conformity to the MUTCD specification. Accordingly, we chose to maintain the red circle/slash over a black arrow on a white background. We also chose to duplicate the dimensions of the standard sign (2' square). Finally, we had to incorporate an electrical triggering capability for ignition of the DII immediately upon reception of a logic signal from the intersection infrastructure.

We produced a set of specifications and submitted it to several vendors. Ultimately we chose to use the services of ElectroTech's of Corona, California, a company which had previously successfully fabricated an LED-based warning signal device. The set of specifications included the following:

- Self-luminous, animated equivalent of a standard left-turn prohibition sign (R3-2) as shown in Section 2B.14 (page 15) of the Manual on Uniform Traffic Control Devices”: (<http://mutcd.fhwa.dot.gov/pdfs/millennium/12.18.00/2B.pdf>)
- The sign should be 24” square (± 1 ”) and should consist of LED emitters placed not more than $\frac{1}{2}$ ” apart. The dimensions and placement of the pattern elements of the display (black arrow, red circle, etc.) should approximate those of the standard sign. The illuminated region of the sign will have rounded corners, but the overall package need not. The sign should be weatherproof, and the front surface should not allow specular reflections. When the sign is extinguished, the patterns within the device should not be apparent to an approaching driver.
- The red circle will have the capability of being presented in two thicknesses by expanding its outer diameter. The default thickness will approximate that of the standard sign while the expanded thickness will be approximately 50% greater. The brightest possible red LEDs should be employed. The timing between the two states of the red circle will be user-selectable in 50 msec increments for each phase.
- The area that appears white in the standard sign will be produced with white LEDs. The white area should be dimmable to allow the user to control the ratio of red and white luminance for the best effect. At the manufacturer’s discretion, there may be a black boundary region between red and white areas of the sign to eliminate a tendency of the portion of the white area adjacent to red appearing as pink.
- The sign should be powered by a standard 120VAC. There should be two low-voltage DC inputs (standard logic level). One turns the sign on but leaves it static (red circle fixed at its lesser thickness). The second causes the “throbbing” of the red circle. When the first input is low, the sign is extinguished.

Note that a great deal of flexibility was built into the prototype DII, allowing user adjustments of both timing and intensity parameters, and allowing independent triggering of the initial ignition and the beginning of the “throbbing” pattern. This was to allow us to optimize the DII in order to provide the maximum conspicuity and minimum observer

reaction time, thus conveying the message to the driver with the maximum efficiency, and to enable us to more easily produce a new set of specifications for a second-generation DII that would be fabricated in the final phase of DII development within the IDS project.

We received from ElectroTech's a set of prototype DIIs and carefully evaluated them over a period of many months. One of them was installed at the test intersection at the Richmond Field Station (see photos below) and has served in many IDS demonstrations as well as in the naturalistic driving experiments described elsewhere in this report. This DII was featured in a CBS televised news program and can be seen in a movie available over the internet (http://www2.cbs5.com/topstories/local_story_039192718.html). Another DII was successfully used in a demonstration at the test intersection at the Turner-Fairbanks Highway Research Center in McLean, Virginia.



Figure 5.2 Richmond Field Station Testing Intersection



Figure 5.3 DII Unit

Based on our experience with the prototype DII units, we developed a new set of specifications for a second-generation DII device, evolved from the prototype to incorporate a number of improvements designed to enhance visibility and conspicuity under all conditions as well as to increase flexibility of use in various ambient light conditions. This new set of specifications included the following improvements:

- Use of warm-white LEDs instead of the “cool” (bluish) ones of the prototype, in order to provide the perception of a purer white background within the sign, in accordance with the white background of the standard MUTCD sign.
- Use of LEDs with a wider angle of distribution to enable greater visibility of the sign when seen off-axis. Use of red and white LEDs with matched angular distribution patterns so that the red/white intensity ratio is preserved when the DII is seen from an oblique angle.
- The white background should extend fully around the border of the display.
- Mounting of the LEDs closer to the protective cover lens in order to reduce internal reflections and thereby increase the visual contrast of the display and enhance the spatial definition of the individual LED emitters, resulting in more sharply defined borders between red, white, and black areas of the DII.

- Two levels of overall intensity of the DII with automatic switching between them by an adjustable ambient light sensor in order to reduce intensity in nighttime conditions for purposes of reducing glare. The intensity levels should be adjustable in order to enable subsequent determination of the optimum levels.
- The throbbing pattern of the red circle/slash should be changed such that the three circular rows expand to five in both the inward and outward directions so that the increase in thickness during the throb has two directional components, thus enhancing the conspicuity of the device.
- A modified power supply so as to reduce the duration of the time courses for ignition and extinction of the LEDs. This will provide sharper transient temporal changes, known to enhance visual system response.
- The range of user-selectable “throbbing” rate should include the capability of higher frequencies, up to four Hertz, to allow us more flexibility in laboratory tests to optimize the timing parameters of the DII for maximum visual response.

Upon receipt of two samples of the second-generation DII, we embarked on a series of laboratory experiments to optimize the timing parameters, employing human reaction time measurements. These will be reported in a later section. Because there was no objective method to optimize the intensity parameters, including red and white LED intensity in both daytime and nighttime modes, we adjusted these by employing subjective observations. The resulting recommended values for intensity are included in the section below on physical properties.

5.2 Physical Properties

Below are photographs of the second generation DII in both states of the throb cycle. Because the exposure had to be greatly reduced to properly render the bright LEDs, the DII enclosure is not visible in the photographs.

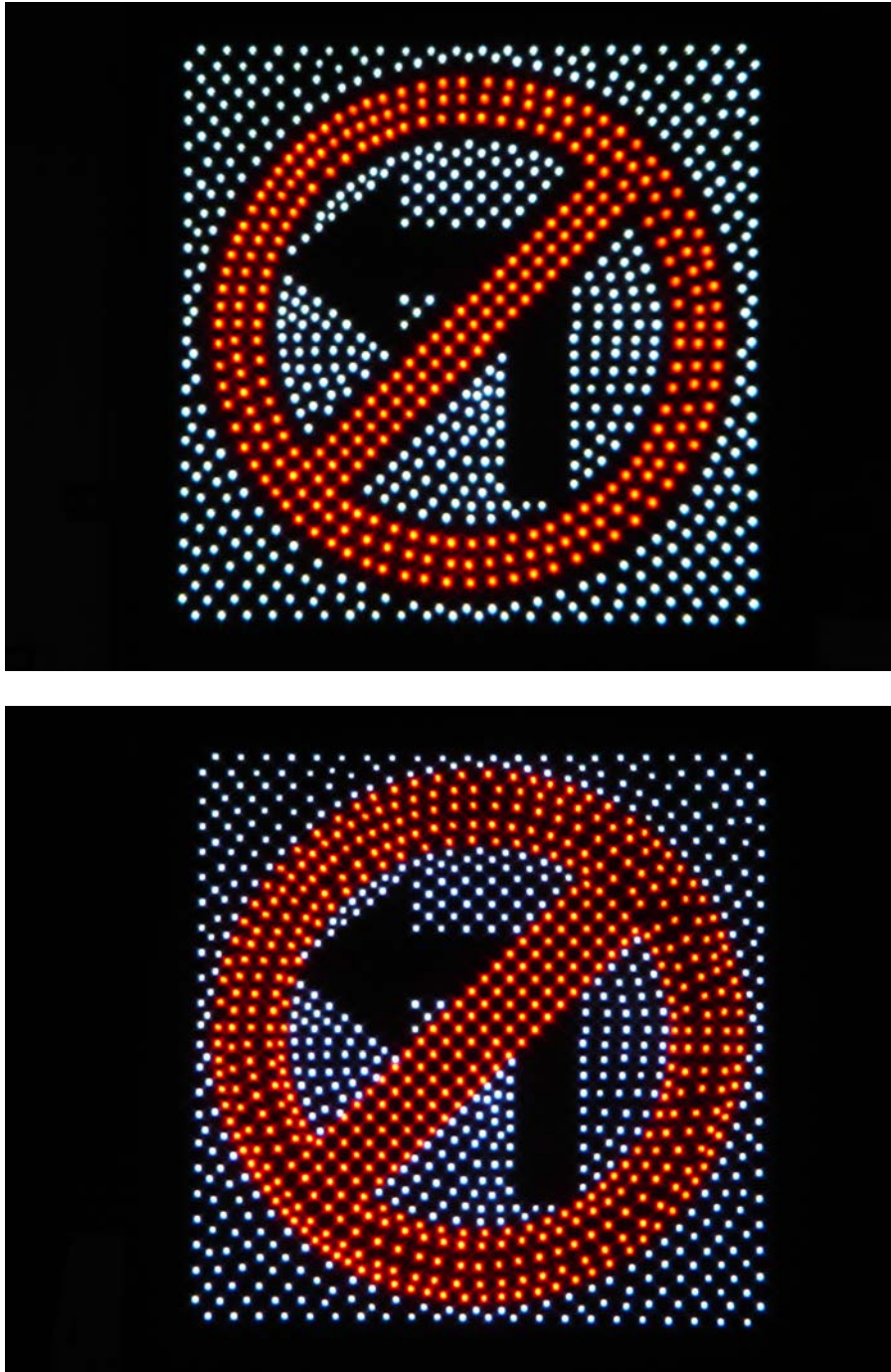

Figure 5.4 Second Generation DII Units

We employed a Tricolor video photometer to produce a two-dimensional luminance profile of the DII on-axis in the nighttime intensity mode that was employed in the laboratory experiments. Below is a false-color luminance map, along with the associated color key.

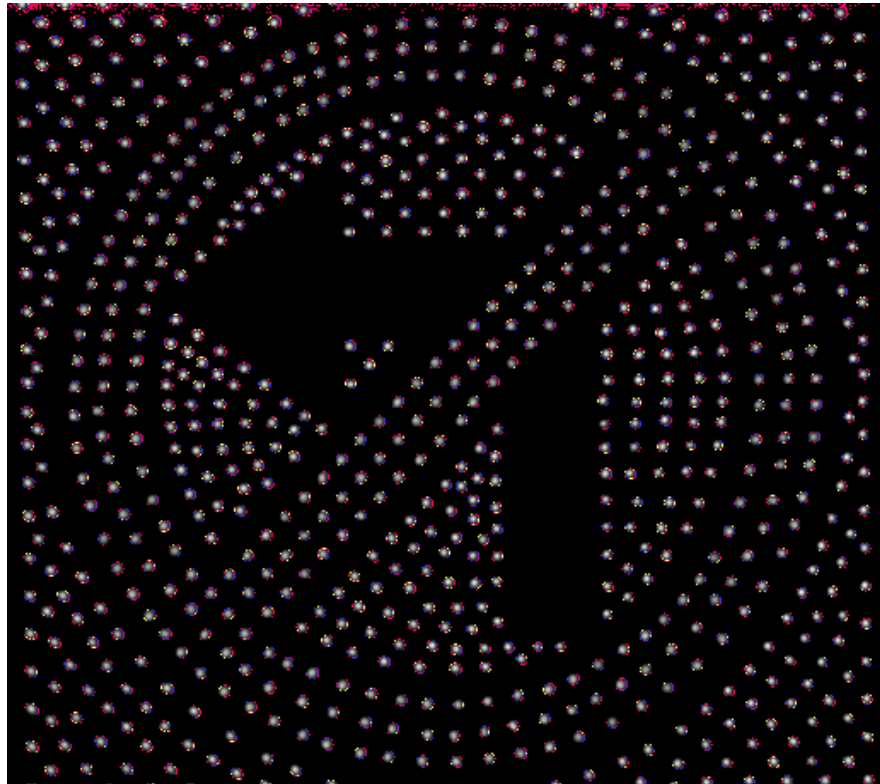

Figure 5.5 (above) Luminance DII Unit

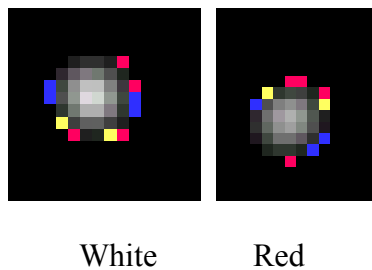
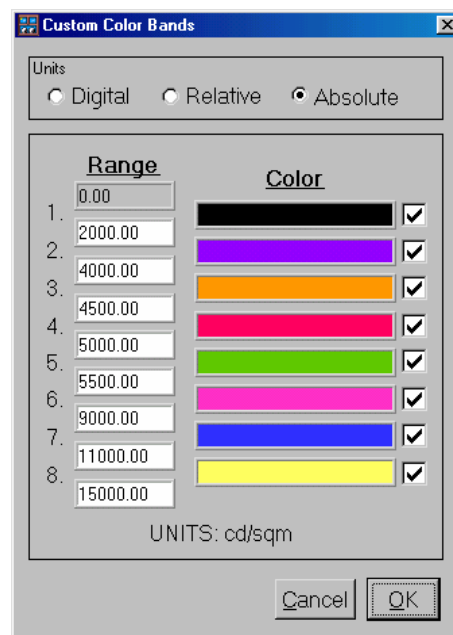

Figure 5.6 Individual LEDs

Figure 5.7 Custom Color Bands. Note that white areas in the image represent luminance that is higher than the ranges shown in the color key, thus greater than 15000 cd/sqm.



The false-color map on the previous page is included so as to provide a better idea of the two-dimensional spatial luminance profile and range of contrast than can be discerned from the actual photographs. However, a more useful specification of the light output of the DII, for purposes of setting the intensity of future iterations, is provided by direct photometry measurements. Using subjective observation techniques to adjust the intensities of the red and white LEDs for the best balance between them, and the best overall intensity to maximize visibility without inducing glare, especially in the nighttime condition, we make the following recommendations:

- In the daytime mode, a photometer reading of the space-average luminance of an area of the DII that includes several LEDs and the surrounding non-luminous matrix yields a luminance of approximately 12,500 candelas per square meter, for either white or red LEDs.
- For nighttime use we recommend a setting that reduces these values to 25% of the daytime intensity.

5.3 Reaction Time Experiments

We performed a series of experiments to determine (1) the optimum throbbing rate and (2) the optimum throb turn-on delay after initial ignition, in order to establish the timing parameters that would result in the fastest visuomotor response. A computer and external electronic control system were used to control the reaction time (RT) experiment and to trigger both the ignition of the DII and the subsequent beginning of the throb cycle. The throb rate and duty cycle are controllable by means of an array of switches accessible from the rear of the DII. A 50% duty cycle was employed for all laboratory tests.

The electronic control system interfacing the computer and DII is shown in the photo below. A *National Instruments Data Acquisition Card* (Nidaq)—model 6024E—is a programmable, electronic circuit card that has 8 digital input/output ports, 16 channels of analog input, and 2 channels of analog output along with various timing and gating

functions. This card plugs into a standard PCI slot in a PC. Its functions can be programmed in the C language (along with using the supplied Nidaq library functions). The use of this card is far superior in timing, accuracy and control in comparison to trying to program the standard serial or parallel outputs on a PC to perform the functions needed for this experiment. (awkward and top-heavy; maybe: “To perform the functions needed for this experiment, this card is far more superior in timing, accuracy, and control than standard programmed serial or parallel outputs on a PC.”)

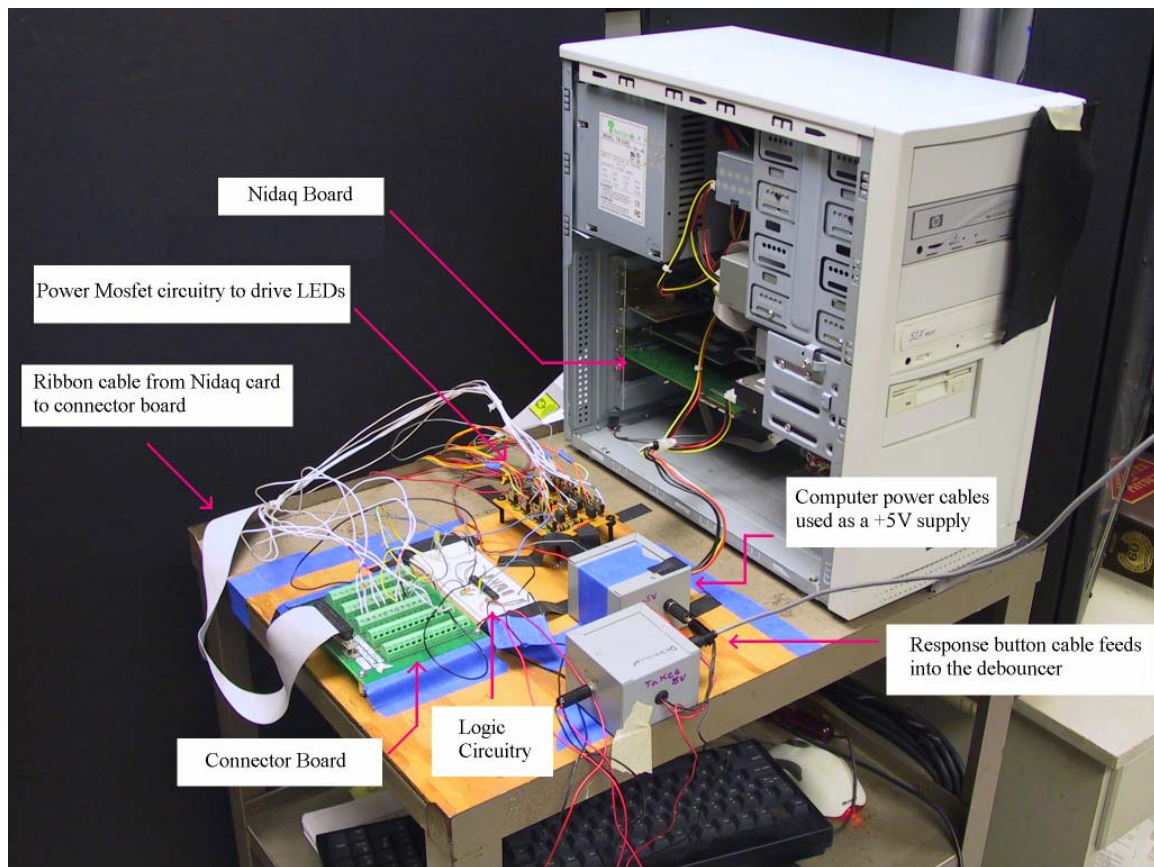

Figure 5.8 Electronic Control System of Computer

A ribbon cable takes the inputs and outputs of this card to a connector. From there the board pins are wired to the logic and LED driving circuitry (see schematic). There is also a debouncer that takes the input from the response button (a noisy signal from a mechanical switch) and provides a “clean” version to the logic circuitry.

Power is provided to the driving circuitry (+12 V) and the logic and debouncer circuitry (+5V) by use of an extra power cable from the computer.

A rough outline of the theory of operation is as follows. LED firing occurs when the Nidaq board issues a +5 volt signal to the digital outputs. The power from the Nidaq board is insufficient to directly operate the LED boards (which require +12 volts). Therefore the digital outputs trigger an external circuit that in turn drives the LED boards. An example of this is shown in the schematic. The Nidaq digital I/O #1 corresponds to pin 17 on the connector board. This turns on the mosfet circuitry (dashed box), which turns on half of an LED board. There are four lights (LED boards) and hence 8 half-boards. For clarity, only one of these is shown in the schematic. For technical reasons, one of the I/O lines was replaced by an analog out line providing +5 volts. Also, a digital line was preferred for the arming logic circuitry (as discussed below). Therefore another analog output took the place of a digital I/O line. The C programming language was used, along with the Nidaq supplied library, to program the Nidaq card. The standard pseudo-random number generator in C was used to provide a time delay between pattern firings. A random delay is needed because the subject can “learn” what the time delay is and anticipate (perhaps without realizing) the firing rather than reacting to it.

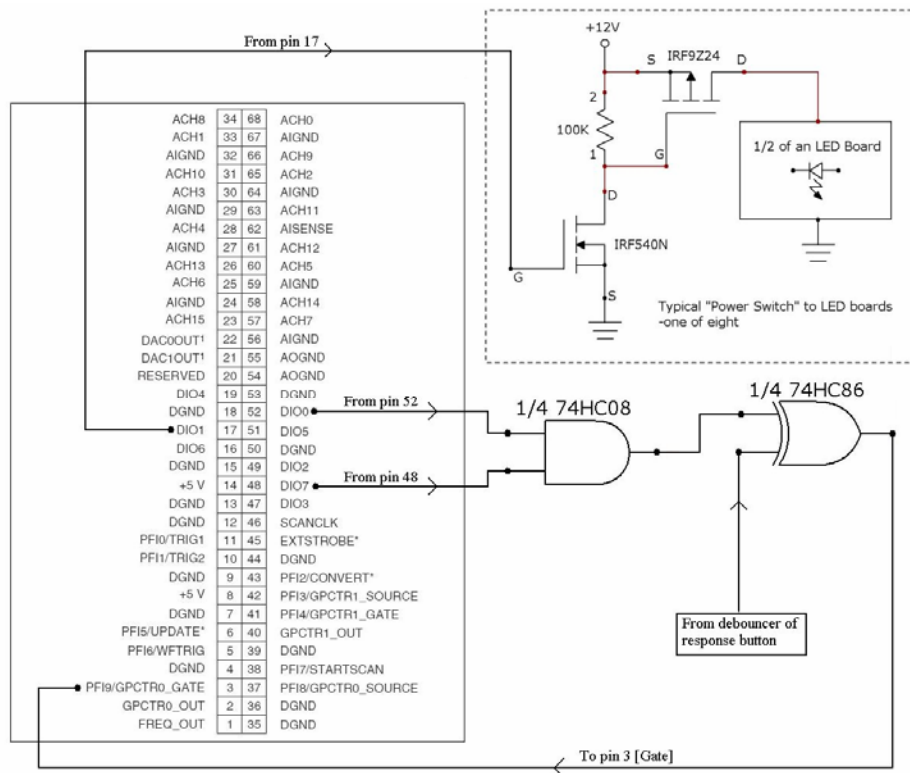

Figure 5.9 Outline of Theory Operation

However, this precaution does not completely obviate the possibility of a premature response. The counter in the Nidaq card, which measures the reaction time, works off of two gate signals—a start signal and a stop signal. It measures the time between these two signals. The start signal is the first light in the pattern that fires (shown as digital I/O # 0, pin 52 in the schematic; not shown is the connection of pin 52 to another MOSFET driving circuit). The stop signal is from the response button of the subject (via the debouncer, which introduces a negligible delay).

These two gate signals both need to go to the Nidaq timing gate at pin 3, but they cannot both be electrically connected directly at pin 3 or the two signals would interfere with each other's circuitry. Therefore the two signals needed to be buffered. Even if this weren't the case, a problem would arise should the subject accidentally hit the response button before the firing actually occurs. The two signals would reverse their roles and the response button could signal a start to the counter and the light firing could signal an end to it. Even if the signals come in the right order, but the subject is just slow and the first light (pin 52) fires twice before the subject responds, the counter could record the time between the light firings instead of the reaction time unless safeguards are put in place. This is why the logic circuitry is used, along with a software safeguard. The digital I/O #7 (pin 48) is used as an “arming” mechanism for the counter gate signals. When pin 48 goes high the output of pin 52 can be passed to the “exclusive or” (XOR), which has its output linked to the timing gate at pin 3. If pin 48 is low, pin 52 (“first light”) has no effect.

The timing gate (pin 3) is not “activated” by the software until just before the light is to fire. Thus a response button push before this time has no effect. Pin 48 goes high just before the first light goes on for the first time in a given pattern. It goes low 10 ms after the first light comes on for the first time. Thus the first firing in a pattern constitutes a start signal but all subsequent firings do not affect the timing gate. Since 10 milliseconds is far below a typical reaction time, the chances of someone hitting a response button during that interval is effectively nil. Of course, after a response is recorded, everything is reset.

The Nidaq card's 100 kHz internal timebase is used for the timing. Thus the accuracy is to the hundredth of a millisecond, far greater than what is needed for this kind of experiment. The reaction time data is held in active memory until the sequence of trials is done and then it is all written to disk, thereby preventing any disk operations from interfering with timing measurements.

A computer program allows the experimenter to select the number of trials and throb turn-on delay for any given run. After each run, a data file is produced that contains the RT for each trial, and also the mean, standard deviation, and standard error.

5.4 Results

We began by having the observer view the DII directly, on-axis, in the lower intensity (nighttime) mode, indoors in the laboratory from a distance of 7 meters, with room overhead lighting on. We employed throb rates of 1, 2, and 4 Hz, and throb turn-on delays of 0, 25, 50, 100, and 200 milliseconds (msec). For each of the 15 possible combinations of throb rate and turn-on delay, 50 trials were performed, and mean RTs calculated. An example of raw data for an individual run of 50 trials is shown below. This is for the combination of 4 Hz throb rate (125 msec thick phase of throb, 125 msec thin phase) and 25 msec turn-on delay

				35	162.26
				36	143.7
Trial	25/125/125			37	173.16
1	187.05	18	140.86	38	151.37
2	158.24	19	186.23	39	189.8
3	159.51	20	169.09	40	190.99
4	169.67	21	162.19	41	141.02
5	165.76	22	161.66	42	162.18
6	149.38	23	168.56	43	174.45
7	143.36	24	173.92	44	183.98
8	138.53	25	155.62	45	169.85
9	136.23	26	170.57	46	160.99
10	145.22	27	158.71	47	179.6
11	145.87	28	175.25	48	147.57
12	155.08	29	175.74	49	156.29
13	144.51	30	162.12	50	179.94
14	163.08	31	147	Mean	161.05
15	128.28	32	163.82	St. Dev.	15.21
16	142.46	33	167.26	St. Error	2.15
17	145.93	34	168.67		

A summary of the results for all 15 conditions is shown in the table below.

Table 5-1 Results I

Throb turn-on delay		1 Hz (500 ms)	2 Hz (250 ms)	4Hz (125 ms)
0 ms	Mean	167.21	159.46	160.99
	St. Dev.	22.11	18.03	27.92
	St. Error	3.13	2.55	3.99
25 ms	Mean	163.32	159.75	161.05
	St. Dev.	18.46	19.79	15.21
	St. Error	2.61	2.80	2.15
50 ms	Mean	158.33	163.75	156.57
	St. Dev.	26.74	15.15	19.57
	St. Error	3.78	2.14	2.77
100 ms	Mean	172.87	167.24	172.90
	St. Dev.	32.19	23.98	23.64
	St. Error	4.55	3.39	3.34
200 ms	Mean	163.57	172.10	158.26
	St. Dev.	27.15	25.41	26.38
	St. Error	3.84	3.59	3.73

The results show only small differences among the various conditions, as well as RTs that are very short, as small as is generally found in visual reaction time experiments. In order to discern meaningful differences when the timing parameters are varied, we must degrade the overall visibility of the DII, making it more difficult to see. When the visibility is degraded sufficiently, a change in timing might lead to a significant change in RT. This approach, while artificial, does correspond to what have termed “worst case” viewing conditions. It is under those conditions that the visibility of a signal is an issue and it is the case that reaction time can reveal visibility differences. Such conditions can occur owing to external factors like poor weather or could be due to observer issues such as blinks, eye movement or inattentiveness.

To degrade the visibility, we overlaid transparent neutral density material over the front of the DII to reduce the intensity by a factor of approximately 33 (equivalent to ND 1.5), and we rotated the DII about its vertical axis to an oblique angle of 30°, which further reduced the intensity by a factor of approximately 10 (ND 1.0). We then repeated the experiment, obtaining the following results:

Table 5-2 Results II

Throb turn-on delay		1 Hz (500 ms)	2 Hz (250 ms)	4Hz (125 ms)
0 ms	Mean	187.00	182.17	174.33
	St. Dev.	23.16	21.61	14.89
	St. Error	3.31	3.06	2.13
25 ms	Mean	184.54	188.78	186.64
	St. Dev.	18.98	23.75	18.28
	St. Error	2.71	3.39	2.61
50 ms	Mean	190.64	187.18	185.30
	St. Dev.	22.78	21.98	22.74
	St. Error	3.25	3.11	3.25
100 ms	Mean	185.67	192.45	184.41
	St. Dev.	32.46	28.84	25.37
	St. Error	4.64	4.08	3.59
200 ms	Mean	188.18	176.26	185.07
	St. Dev.	27.19	15.37	26.82
	St. Error	3.92	2.17	3.79

Note that the RTs are approximately 20 msec longer than before the visibility was degraded, but this represents only a 12% increase and, again, there are only small differences in RT among the various conditions. We then endeavored to degrade the visibility of the DII still further, approaching the point where detecting its onset became a “threshold” phenomenon. To accomplish this, we had the subject view the DII (still covered by neutral density material and positioned at an oblique angle) through a pair of inverted binoculars (as shown in the photographs below), which had the effect of making the DII appear at a factor of 10 greater distance. We again ran the experiment in all 15 conditions; results are presented in the following table.

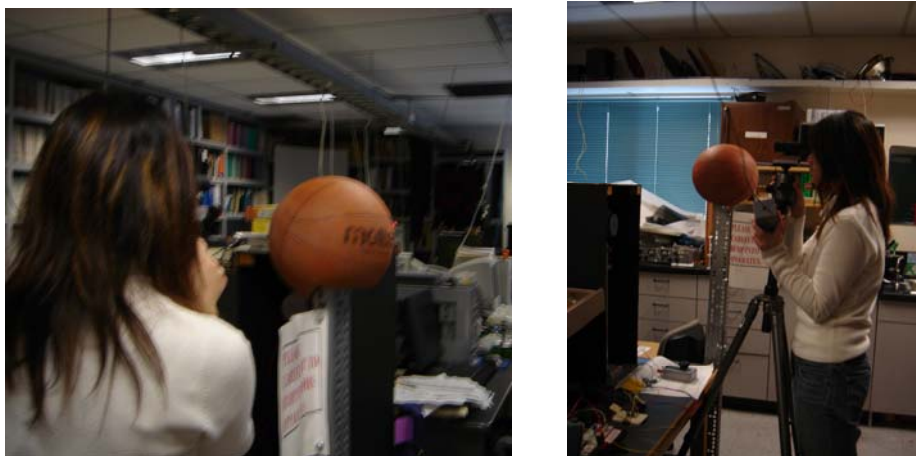

Figure 5.10 Experiment of DII viewing

Table 5-3 Results III

Throb turn-on delay		1 Hz (500 ms)	2 Hz (250 ms)	4Hz (125 ms)	Mean
0 ms	Mean	370.9	355.3	417.0	381.07
	St. Dev.	130.5	56.3	122.0	
	St. Error	18.5	7.8	17.3	
25 ms	Mean	453.5	407.7	390.9	417.37
	St. Dev.	169.0	76.2	121.4	
	St. Error	23.9	10.8	17.2	
50 ms	Mean	501.5	435.2	440.1	458.93
	St. Dev.	153.5	135.1	118.1	
	St. Error	21.7	19.1	16.7	
100 ms	Mean	380.6	432.4	511.3	441.43
	St. Dev.	138.2	91.2	150.4	
	St. Error	19.5	12.9	21.3	
200 ms	Mean	476.0	521.1	419.0	472.03
	St. Dev.	194.6	188.4	93.5	
	St. Error	27.5	26.6	13.2	
Mean		436.50	430.34	435.66	

Note that the RTs are now approaching ½ second in duration and that there are some significant differences among the various conditions. In this table we have also included the means of RT across turn-on delays for each throb rate, and across throb rates for each turn-on delay, in order to more easily look for trends that would suggest additional experiments.

Inspection of the data indicates approximately the same average RTs for the three throb rates, averaged across throb turn-on delays, but there seems to be an advantage (lower RT) to the 0 msec throb turn-on delay, averaged across throb rates.

It was decided to conduct additional experiments corresponding to the rows in the above table for 0, 25, and 100 msec turn-on delays. These were conducted on three separate days. Limiting the number of conditions allowed us to increase the number of trials without fatiguing the observer. Accordingly, we conducted 120 trials for each combination of throb turn-on delay and throb rate. We separated these 120 trials into three blocks of 40 trials and changed the order in which the throb rates were presented for

each set of 120 trials so as to minimize ordering effects (due either to learning or to observer fatigue) that might have influenced the results in the previous experiments. Because of the greatly reduced visibility of the DII, there were some trials in which the observer failed to see the activated DII for an abnormally long time. In order not to skew the mean by these “outliers”, but also not to throw out the information contributed by such trials, we changed the values of RT to the longest legitimate RT value found in the experiment for purposes of calculating the mean RT.

The results of these three experiments are seen below.

0 msec throb turn-on delay

Throb rate	1 Hz	2 Hz	4 Hz
Mean	355.1	340.4	353.0
St. Dev.	72.4	56.7	63.9
St. Error	6.6	5.1803	5.8293

25 msec throb turn-on delay

Throb rate	1 Hz	2 Hz	4 Hz
Mean	347.7	345.1	322.6
St. Dev.	88.8	67.3	57.8
St. Error	8.1	6.1	5.3

100 msec throb turn-on delay

Throb rate	1 Hz	2 Hz	4 Hz
Mean	468.2	447.2	418.9
St. Dev.	106.8	92.1	93.7
St. Error	9.7	8.4	8.6

Inspection of this data showed that for two of the three turn-on delays, there was a statistically significant advantage to the 4 Hz throb rate. Accordingly, we decided to conduct one additional experiment, keeping the throb rate constant at 4 Hz and varying the turn-on delay among 0, 25, and 100 msec, again with 120 trials per condition separated in blocks of 40 trials, interleaved to minimize ordering effects. The results of this experiment are shown below.

4 Hz throb rate

Delay	0 msec	25 msec	100 msec
Mean	312.1	348.6	388.7
St. Dev.	75.5	73.8	76.6
St. Error	6.9	6.7	7.0

Here we see a significant advantage to the 0 msec turn-on delay. While the results are not identical to those in the three corresponding cells in the three tables at the top of the page, we believe that the comparison in the table of the 4 Hz experiment is valid because all the data was collected in the same session rather than at three different sessions on different days, over which period the state of the observer may have changed.

We are thus led to make a recommendation that future iterations of the DII present a throb at a rate of 4 Hz and that the throb cycling begin immediately upon ignition of the DII. The reason we evaluated various throb turn-on delays was due to the possibility that the resulting additional transition of state of the DII soon after ignition might increase conspicuity and reduce reaction time, but the data suggest otherwise. This is fortuitous as less timing circuitry is now required within the DII.

6 SUMMARY OF DRIVER BEHAVIOR STUDIES

6.1 How do drivers approach left-turn intersections?

The Berkeley instrumented-vehicle field test (section X.2) was the only data collection that really examined the left-turn approach in detail from the SV driver's point of view. This study first broke intersection approaches into two categories based on the presence or absence of a lead vehicle, concluding that the presence of a lead vehicle more or less dictates the SV's approach. If there is no lead vehicle causing interference, then the SV approach yielded three interesting categories of behavior:

1. The SV turns without stopping, dropping to a minimum speed between 5 and 7 m/s.
2. The SV slows to let a POV clear, dropping to a minimum speed between 2 and 4 m/s.
3. The SV must stop prior to or within the intersection.

In some cases, a driver's intent to follow any of these trajectories might seem apparent from as far back as the moment their vehicle enters the turn lane (40 to 60 meters from the intersection stop bar). However, this study also concluded that the approach and turning decision are fluid and constantly being re-evaluated with an expectation of a change in conditions (e.g., the light may change from green to amber). Drivers are, in essence, prepared to change their decision and stop at a moment's notice. Typical reaction time to an event such as a traffic light change was observed to be fairly rapid, on the order of .4 seconds.

Furthermore, driver behavior is constrained by (and fast reaction times are aided by) vehicle dynamics. Typical approach speeds when entering the left-turn lane ranged from 9 to 13 m/s (20 to 30 mph), but the fastest typical turning speeds ranged from 5 to 7 m/s (11 to 15 mph). This means that during the left-turn approach, drivers are already using the brake to slow the vehicle down. Any reaction that is needed to an unexpected event, a signal change, or an IDS countermeasure is simply an adjustment in brake pressure.

Similar observations were made during the RFS instrumented-intersection experiment (section X.3), and the mean turning speed as the SV entered the intersection (when it turned without stopping) was within the same 5 and 7 m/s range that was found in Berkeley instrumented-vehicle field test. In both studies it was very difficult to accurately predict from the SV approach whether the driver intended to stop and wait for the POV to pass or whether the driver intended to turn in front of the POV without stopping.

6.2 How long does it take drivers to traverse an intersection?

Both the roadside observations (section X.1) and the Berkeley instrumented-vehicle study (section X.2) investigated the question of SV turning time, and both studies concluded that the important factors dictating turning times included the intersection geometry, the SV approach behavior (turned without stopping or turned from a stop), and the presence of pedestrians.

The most accurate measures of SV turning time came from the roadside observation video analysis, which had a clear view of the SV as it both entered and exited the intersection. Thus, the turning time clock started when the SV was observed to start moving and ended when the SV's bumper was observed to clear the intersection. The mean turning times reported in this analysis varied from 2.6 to 4.4 seconds by intersection, with slightly faster turning times being associated with turned-without-stopping behavior (an overall mean of 2.5 s with a standard deviation of 0.5 s). The presence of pedestrians increased the overall mean turning time to 4.6 s (standard deviation 1.8 s) and increased the variance more than threefold.

The Berkeley instrumented-vehicle study also examined the turning time results ranging from 5.2 to 7.8 seconds; however, there were differences between studies due to the measurement techniques. The instrumented-vehicle study started the clock when the driver released the brake pedal (taking into account a reaction time not measured in the roadside observation) and ended when the crosswalk was visible in the rear-facing camera (which likely pads the turning time measurement). Nevertheless, the instrumented-vehicle study was able to conclude that neither age nor gender played a significant role in determining or predicting the turning time.

Although the RFS instrumented-intersection experiment (section X.3) was unable to directly measure turning time, it was noted that typical driver behaviors, variance in turning speed or cutting the corner when making a left-turn, had the potential to introduce quite a bit of error (on the order of 0.7 seconds) into the predicted outcome.

Overall, the implications for IDS are positive. First, any prediction or warning algorithm does not need to take an individual driver's age or gender into account, which is good news given the relative difficulty in obtaining this information. Second, any warning or prediction algorithm will need to be "tuned" to its particular intersection installation, since turning times vary so widely between intersections. Although this requirement is more difficult, it is not entirely impossible, and further research is recommended in this area.

6.3 What "gaps" in the oncoming traffic are typically accepted or rejected?

One of the primary and perhaps the most difficult question tackled by each of the data collections was the question of "gap" acceptance. Unfortunately, it is very difficult to directly compare results across the various studies due to differences in the definition, measurement, and computation or prediction of "gap." One initial problem in the definition of gap comes from the fact that there are two distinct cases: 1) where the SV has stopped in the intersection and is waiting for an appropriate gap and 2) where the SV is still approaching the intersection and making the decision to turn without stopping in the intersection. The latter case brings in the unique challenge of defining "gap" with a moving SV, where decisions are being made before the vehicle even reaches the intersection. One solution that has been proposed to standardize the definition and measurement of "gap" is the concept of "trailing buffer." The trailing buffer simply subtracts a prediction of POV's arrival time from a prediction of the SV's time required to clear the intersection, resulting in a measure equating to the amount of spare time (should the SV decide to turn in front of the POV), which could be calculated at any given point in the approach. The prediction models would take into account both cases of stopped and moving SV.

The roadside observation study (section X.1) explored the question of gap acceptance in two separate analyses. In the radar-based analysis, the POV distance and speed was measured as the

SV crossed the point of conflict, and thus, only the accepted gaps were considered. Furthermore, the results don't consider individual vehicle cases or individual driver willingness to accept gaps smaller than those presented. Nevertheless, converting to the results to the common measure of "trailing buffer," the study concluded that 20 percent of the LTAP-OD turns were made with predicted trailing buffers of less than 1 second, increasing steadily to at least 70 percent of the turns being made with predicted trailing buffers less than 5 seconds.

In the video-based analysis of the roadside observation study data, the POV time-to-intersection (t_{2i}) was measured *post hoc* on the video and includes any speed adjustments made by the POV driver during the intersection approach. Both the accepted and rejected gaps were recorded; however, the results still don't consider individual vehicle cases or individual driver willingness to accept gaps smaller than those presented. Overall, this analysis found that the random distribution of gaps occurring in traffic can be described by a log-normal distribution with about 38 percent of the gaps being less than 3 seconds, 50 percent being greater than 3 seconds but less than 9 seconds, and the remainder being greater than 9 seconds. All gaps below 3 seconds were rejected by drivers and all gaps above 9 seconds were generally accepted by drivers; however, there were intersection effects, probably due to the actual intersection geometry and traffic conditions. The gaps corresponding to overall gap acceptance rates of 15th, 50th, and 85th percentile were 4.2, 6.3, and 9.6 seconds. Converting these results to trailing buffer (by subtracting a mean turning time of 3.3 seconds), the trailing buffers corresponding to overall gap acceptance rates of 15th, 50th, and 85th percentile would be 0.9, 3.0, and 6.3 seconds.

While the roadside observations were insensitive to the SV approach, the Berkeley instrumented-vehicle field test (section X.2) examined both accepted and rejected gaps for drivers approaching an intersection, based on whether the gap was accepted and the driver turned without stopping or whether the gap was rejected and the driver slowed or stopped. Estimates of the POV speed and distance were provided by instrumented-SV's forward-looking radar. Although the driver population was more homogenous in this study, the sample size was very small and limited to only those gaps traffic randomly presented during the test. The mean accepted trailing buffer resulting in a turn without a stop was 4.3 seconds (± 3 s), and the mean rejected trailing buffer

resulting in a stop was 0.5 seconds (± 2.5 s), showing considerable overlap between the ranges of accepted and rejected gaps.

The RFS instrumented-intersection experiment (section X.3) examined both accepted and rejected gaps on an individual basis, presenting each driver with a series of gaps spanning from always-rejected to always-accepted. However, the study was conducted on a closed test track, without pedestrian traffic, with only one approaching POV, and with a permanently green light for the SV and POV. These almost ideal and artificial conditions presented to the SV probably account for the fact that results showed a much narrower range, on the order of only 3 seconds of predicted trailing buffer, between gaps with 0 percent acceptance and gaps with 100 percent acceptance. The experimental conditions (as well as on-going questions on just how exactly to compute “trailing buffer”) also probably account for the fact that, overall, drivers were fairly aggressive in the study, finding a more than 50 percent turn rate when the predicted trailing buffer was just under a half-second, increasing to a 100 percent turn rate when the predicted trailing buffer was over 2 seconds.

6.4 When are decisions being made by the SV driver?

Both the Berkeley instrumented-vehicle field test (section X.2) and the RFS instrumented-intersection experiment (section X.3) examined the question of decision point. In the context of an IDS system, the decision point is one of the most critical elements as it directly dictates the timing or onset of any warning. In the field test, the concept of decision point was examined by contrasting the SV approach curves for cases where the SV turns without stopping and cases where the SV decides to stop for an approaching POV. In comparing these two conditions it was possible to start to discriminate between the two behaviors by approximately 17 m (or 2 seconds) from the stop bar. Given that a difference in the vehicle approach was already detectable at 2 seconds from the stop bar, it was expected that the decision to stop had already been made at least a half-second prior.

The RFS study further built upon these findings and experimentally tested DII warning onsets at 2, 3, and 4 seconds from the stop bar. Overall, the study surprisingly found that drivers were

more or less insensitive to the warning point, which probably relates to the earlier conclusions regarding the fluidity of the decision point. The optimal warning point for all drivers was found to be around 3 seconds before the stop bar. There was also a slight age bias as older drivers didn't mind the warning being earlier and younger drivers didn't mind the warning being later.

6.5 How can a conflict between the turning SV and POV be accurately predicted?

Overall, drivers in the RFS instrumented-intersection experiment (section X.3) were relatively receptive to the concept of a LTAP-OD DII, and the presence of a DII reduced the turn rate by an average of 20 percentage points (being more effective as the predicted trailing buffer decreased and less effective as the predicted trailing buffer increased). However, there are at least three issues which require further research before the implementation of any field operational test could be considered.

First, there are still significant questions or debates regarding how, exactly, the trailing buffer should be calculated. While the trailing buffer measure appears to be correlated with turning rate, the formulas used to predict SV and POV arrival times still need some fine tuning. As an example, should the SV prediction trajectory be based on mean speeds or on the 85th percentile speeds, which would help to account for more aggressive driver behavior? Furthermore, there are questions regarding the tolerance of errors or variance. A 4-second intersection approach can easily result in a half-second of variance (standard deviation) simply based on driver behavior. Crossing the intersection (turning times) also resulted in at least a half-second of variance on the low end, suggesting that any algorithm may start off with errors on the order of 1 second simply due to the variance in driver behavior before measurement and sensor errors.

Second, the question still remains about how to select the warning criteria. All of the studies in this section found overlapping ranges of accepted and rejected gaps. Although the gap acceptance rate increases as the trailing buffer increases, there was no natural cut-off point or obvious policy on which to base the warning criteria. Fortunately, driver options did tend to side with the DII as the warning criteria was lowered.

Third and finally, the roadside observation studies showed that there were significant differences between intersections in parameters such as turning time, traffic volumes and available gaps, and approach speeds. Fortunately, although driver behavior varied widely, it was found to be somewhat linked to vehicle dynamics, and some variables such as the posted speed limit will have little affect. Even with increased speed on the approach, vehicle movements will still be related to the maximum turning speeds which are governed by the intersection geometry. Still, these differences suggest that any LTAP-OD warning algorithm will need to be fine-tuned to its intersection, and more research is needed on this issue.

7 DATA FUSION FOR VEHICLE DETECTION: USING RADAR AND LOOPS FOR INTERSECTION DECISION SUPPORT (IDS)

7.1 INTRODUCTION

For reliability and performance (i.e., fast response) of the system, the decision making needs to be based on real-time information. Thus this information is safety- and time-critical. Reliability can be achieved through the fusion of the information from different sources. A critical problem for the intersection is the detection of the current state of all the vehicles around the intersection: their position – Distance to Intersection (D2I), direction, speed and possibly acceleration. The direct measurement of this information is from sensors at or near an intersection. These sensors may include radar, used for the detection of vehicle speed and D2I, and loop detectors, used for the estimation of vehicle position and speed and presence. Two types of loop detectors are used: micro-loop detectors and traditional loop detectors. Essentially, they are the same in physical characteristics. The only difference is their size. The traditional loops are those popularly used in highway systems, which are about $2 \times 2m^2$ in size. Micro-loop, on the other hand, is within a 20 cm range. Thus the detection range of the two is different. However, the 3M Canoga loop cards for those two types are exactly the same with the same specifications.

In our effort, a Doppler radar is used and has been shown to be a good measurement approach for the speed and D2I of a moving vehicle, and a poor measurement approach for a stopped vehicle or a vehicle moving in the direction perpendicular to the radar pointing direction. We have also found that using radar measurements to distinguish multiple vehicles at an intersection is a very difficult issue. To overcome those difficulties, loop detectors were used to compensate for limitations of radar systems. To practically achieve this, it is necessary to have (a) a reliable radar detection, target tracking, (b) a detection and estimation algorithm for loops, and (c) a data fusion algorithm for both radar and loop estimation. This report presents our findings in

developing this algorithm. Specifically, it describes the hardware and software setup for the overall detection system, radar detection and estimation, micro-loop detection and estimation, and data fusion for the estimation of vehicle presence, speed, and D2I. Characteristics of those sensors related to vehicle detection and estimation are also discussed.

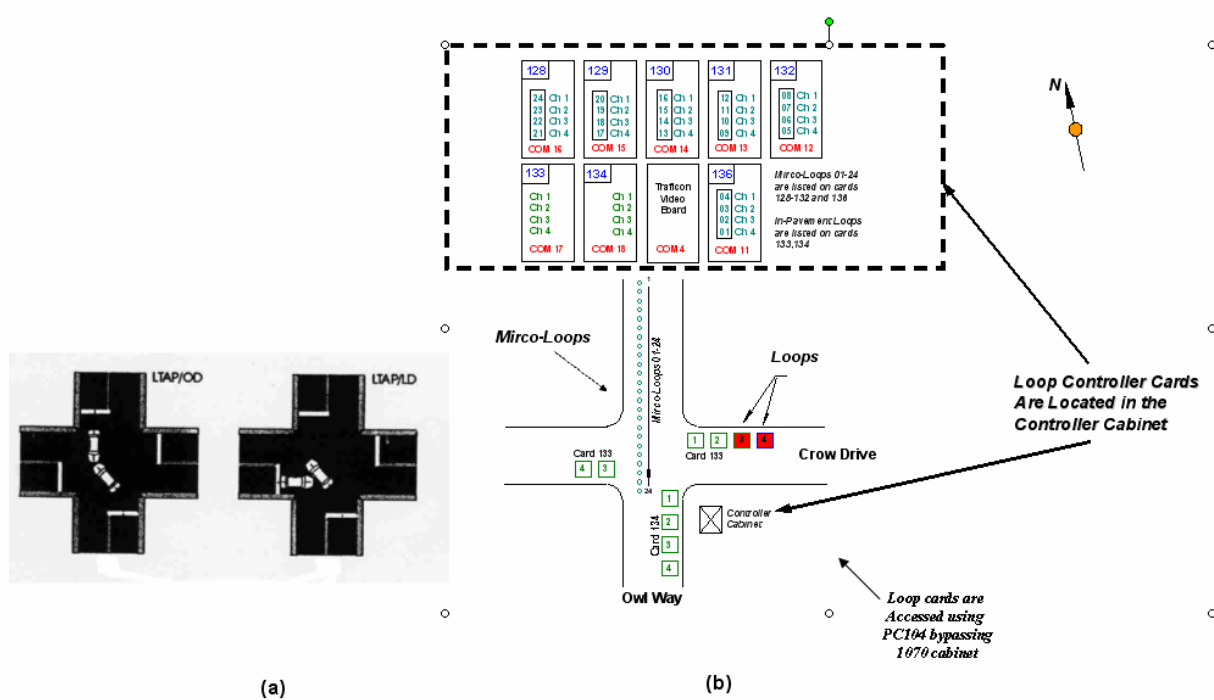

Figure 7.0.1 (a): Scenarios for LTAP/OD and LTAP/LD; (b) Overall system structure for Test Intersection Detection Systems, Loops are accessed from PC/104 bypassing the 2070 Controller

7.2 HARDWARE SETUP AND DATA COLLECTION

This section describes the hardware setup and use of a test vehicle, which has both manual and automatic driving capability, to obtain ground truth data. Sensor detection and estimates are compared to show performance.

7.2.1 Overall System Structure

The overall system setup and data flow are shown in Figure 8.1. A PC/104 computer is set up independent of the processor of the 2070 controller in the cabinet. It is responsible for running all the sensor detection, filtering and fusion algorithms and controlling the warning display. It is important to mention that there is direct access to the loop cards

from the PC/104 by bypassing the controller cabinet. The 2070 controller cabinet can only read vehicle count and flow, not other loop information. Because smart 3M Canoga loop cards have been installed, such a bypassing connection allows us to read other information from the loops, including start-detection time, raw presence signal, and loop fault status. The correspondence of both traditional and micro-loop cards is also shown in Figure 8.1.

7.2.2 Radar and Micro-Loop Setup

The physical setup of the Intelligent Intersection at California PATH is shown in Fig. 8.2. There are 24 micro-loops on the left lane north of the intersection with an inter-loop distance of 2.7m.

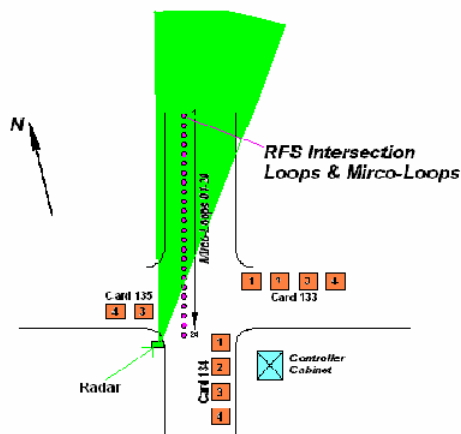

Figure 7.0.2 Radar setup and field of view with respect to the micro-loops

7.2.3 Vehicle Ground Truth and Data Collection

The vehicle speed ground truth is determined by using an instrumented automated Buick LeSabre as the test vehicle. Before the test, the test vehicle's wheel speed is calibrated to match the ground speed by using magnetometers to measure the magnets buried in the ground. This allows vehicle speed and moving distance to be estimated solely based on the wheel speed. Wireless IEEE 802.11b is used to pass vehicle information to the control cabinet. Each loop has its own time stamp. The start time and end time of detection is

recorded with respect to this local timing. This causes a problem for synchronizing local timing with that of the time stamp corresponding to the vehicle speed. To avoid this problem, the time stamp on the main computer (PC-104) in the controller cabinet is used to synchronize data reading from all the loops and that from the test vehicle. This means that a small time delay between the card time and the computer time is ignored. Those data are saved after each run for later analysis.

7.3 SENSOR DETECTION, FILTERING AND FUSION

For an IDS system to make a decision whether there is any danger of a crash, the intersection sensors need to know the status of all the vehicles approaching or at the intersection. Vehicle status can be described as: vehicle position (x,y), speed, and acceleration. This is achieved using remote sensor detection in conjunction with loop detectors. The combination of remote and loop detector is not just for reliability; their functions are also complementary to each other. Several remote sensors could be used. Considering its cost, effectiveness and simplicity, Eaton Vorad Doppler radar was adopted. Due to the Doppler Effect, Eaton Vorad radar is particularly good for moving target detection as long as the direction of the movement is not perpendicular to the radar beam. It can be considered a speed-based detector because of the Doppler Effect. However, for stopped vehicles or vehicles moving in the direction perpendicular to the radar beam, target(s) will disappear from radar detection. In these cases, loop detectors become prominent in function.

7.3.1 Radar Data Filtering for Target Detection

A standard Eaton Vorad set (EVT-300) provides 7 targets' information with update intervals of 75ms, which includes target ID, speed, distance, and azimuth. This means that the radar set has an internal tracking algorithm besides filtering. However, in complicated traffic situations, the internal tracking algorithm cannot provide continuous tracking for multiple vehicles in its view. This is because of two main physical difficulties: (a) the radar beam cannot distinguish two objects which are laterally close; (b) if relative speed is detected/filtered to be zero for some time period, then the same object will be considered a different target by the radar internally. Thus a different target

ID will be assigned to it. Due to these characteristics, the target ID number changed frequently when it was used on a moving transit bus. Even for static use for IDS, probability of temporary target loss for a single lane vehicle detection is still higher than 0.15.

To achieve reliable vehicle status detection, it is necessary to use the 7 targets' data to form some fixed number (the number of lanes) of continuous tracks. The advantage is that we do not have to build too much tracking and we may know in principle how a track should be dropped out. For example, from targets in different channels with lateral positions within a range of a lane (or even a width of a vehicle), we can consider them the same target even if they have different target IDs. In this way, one can significantly reduce the discontinuity in tracking. It is noted that target tracking for Intersection Decision Support (IDS) is slightly different than that used on Frontal Collision Warning System FCWS on transit buses. The differences are that, in the IDS deployment, the sensors are fixed on the ground and in the field of view; the number of lanes is fixed for IDS application. Thus all the static roadside objects will not be detected due to Doppler Effect. This means that radar data are cleaner for IDS use than those for transit buses for urban and suburban operations.

7.3.1.1 Radar Target Tracking and Filtering

As discussed above, for a safety critical warning system the intersection needs to detect and continuously track a target as long as it is within the field of view of the radar. To achieve this, it is necessary to practice prediction in the tracking algorithm in addition to target association. Other tracking and association methods are referred to [BAR]. [MOBUS] uses a Kalman filter approach for multi-target tracking in developing Adaptive Cruise Control (ACC). Distance-based tracking algorithms are used for Lidar (Laser Radar) for developing Frontal Collision Warning System [WANG]. Methods used here are for simplicity, reliability and effectiveness. Particularly, the characteristics of the Doppler radar are fully utilized.

The main problem for following vehicles using radar is in detecting targets in the front though there may be multiple vehicles in each lane. A characteristic of Eaton Vorad is that it is speed-based measurement, which can be used in radar target tracking and association. This means that the criteria for building tracks corresponds to vehicles; thresholds should be set with respect to target speed. This can be called speed-based, which is different than those of distance-based measurement like Laser radar or video cameras. The following terminologies and notations are used:

Track – A track corresponds to an expected target which may be composed of several time series of assigned data. Each time series of data corresponds to one parameter or state (speed, distance, azimuth) of the target. A tracking algorithm is a rule that redistributes the data from the 7 channels of the data set. Suppose the number of lanes is N , the maximum number of targets to be tracked is also N . The following algorithm defines a rule that redistributes the data from the 7 channels of the radar in real time.

t – discretized time step, $t = 0, 1, 2, \dots$

j - radar channel index, $j = 1, 2, \dots, 7$

i – the number of tracks (the number of targets), $i = 1, \dots, N$

$rate(j, t)$ - range rate measure of radar channel j in [m/s] at time t

$range(j, t)$ - range measure of radar channel j in [m] at time t

$az(j, t)$ - azimuth measure of radar channel j in [rad] at time t

$v(i, t)$ - speed (range rate) of the i – th built track, [m/s]

$x(i, t)$ – range (distance) of the i – th built track, [m]

$\theta(i, t)$ – azimuth (angle) of the i – th built track, [rad/s]

$m(i)$ - assigned target ID of the i – th built track from radar tracking ID number

1. **Algorithm for tracking:** All the tracking parameters are assigned as 0 before starting. To build continuous tracks for multiple targets:

For $j=1:7$

For $i=1:N$

If $m(i) = 0$

$rate(j,t) > 0.0$

$rate(j,t) < 35.0$

Then

$x_r(i,t) = rage(j,t)$

$v_r(i,t) = rate(j,t)$

$\theta_r(i,t) = az(j,t)$

$m(i,t) = id(j,t)$

If $m(i) \neq 0$ and

$rate(j,t) > 0.0$

$rate(j,t) < 35.0$

$|rate(j,t) - v(i,t-1)| < \varepsilon_v$

$|az(j,t) - \theta(i,t-1)| < \varepsilon_\theta$

Then

$x_r(i,t) = rage(j,t)$

$v_r(i,t) = rate(j,t)$

$\theta_r(i,t) = az(j,t)$

$m(i,t) = id(j,t)$

For those track $k, k \neq i$

$x_r(i,t) = x_r(j,t-1)$

$v_r(i,t) = v_r(j,t-1)$

$\theta_r(i,t) = \theta(j,t-1)$

$m(i,t) = id(j,t-1)$

If more than one current measurement satisfies these conditions, then use the one with the smallest error.

2. **Filtering:** For the built tracks, it is necessary to smooth the data series. For radar distance measurement, low-pass digital filters [LYN] are used for smoothing the measurement. Particularly, the following filter is used:

$$\bar{x}(t) = \lambda \cdot x(t) + (1 - \lambda) \cdot \bar{x}(t - 1)$$

$$0 < \lambda < 1$$

where $\bar{x}(t)$ is the estimate of current time step, $x(t)$ is the measurement of current time step, and $\bar{x}(t - 1)$ is the estimate of previous time step.

3. Prediction: A simple prediction method is used to predict the vehicle speed and distance based on acceleration for the case when radar misses the target. Let Δt be the time step. A simple kinematic model is used for the prediction:

$$x(t) = x(t - 1) + v(t - 1) \cdot \Delta t$$

$$v(t) = v(t - 1) + a(t - 1) \cdot \Delta t$$

At each time step, acceleration $a(t)$ is calculated and saved in the buffer. If there is no target loss, $a(t) = [\bar{v}(t) - \bar{v}(t - 1)] / \Delta t$. If there is a temporary target loss,

$$a(t - 1) = [\bar{v}(t - 1) - \bar{v}(t - 2)] / \Delta t$$

$$\bar{v}(t) = \bar{v}(t - 1) + a(t - 1) \cdot \Delta t$$

$$\bar{x}(t) = \bar{x}(t - 1) + \bar{v}(t - 1) \cdot \Delta t$$

are used as estimates.

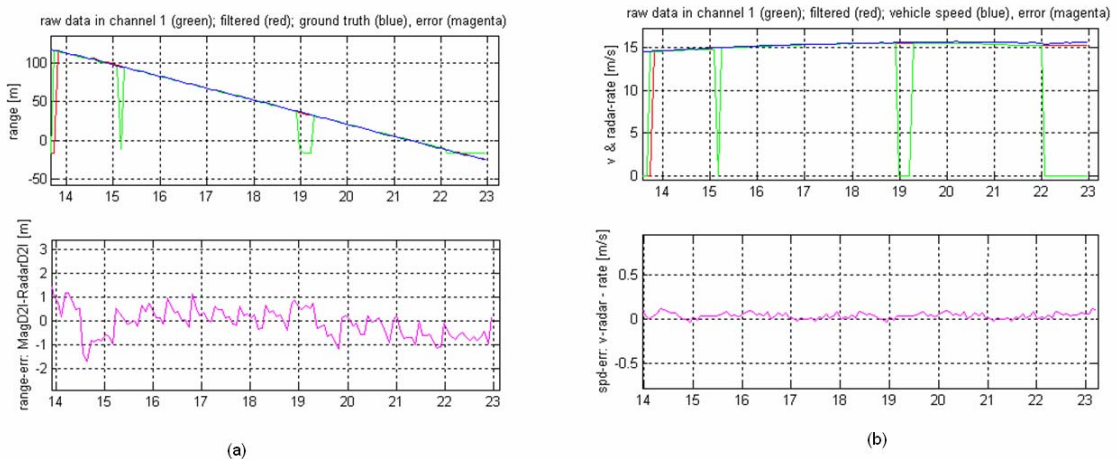

Figure 0.3 Radar filtering, tracking, and prediction

7.3.1.2 Discussion for Test Data

Upper plots: green = radar measurement; red = range and speed, respectively, after data association and prediction; blue = vehicle speed and distance ground truth. Target loss happening twice appears in both distance and speed tracking. The first gap has been filled by data association; the second gap has been filled by prediction. Lower plots: estimation error; radar distance and speed measurement error for target within 100m are independent of the distance. The characteristics (pattern) of measurement for both parameters are almost the same; distance error is within the range of $[-1.0, 1.0]$ and speed error is within the range of $[-0.02, 0.1]$. Such measurement accuracy is very satisfactory for IDS purposes.

7.3.2 Micro-loop Detection

To achieve more reliable vehicle detection, such as vehicle location (D2I) and speed, different levels of information from smart loop cards are used, including detection start time and raw presence data. These two types of data are analyzed loop-by-loop for their characteristics; for example, time sequence recorded versus the loop sequence as the moving vehicle is detected. It turns out that presence is more consistent in this aspect, which is very important for vehicle speed and D2I estimation.

7.3.2.1 Information Retrieval from Micro-loops: Detection Start Time

There are several ways to retrieve information from micro-loops. The following information is first chosen to be used for micro-loop detection for each loop: time stamp; detection start time; detection duration; vehicle count; and current-loop status. The properly scaled and shifted start time sequence is shown below. Four loop circuits are connected to loop cards. Different colors represent loop cards connected to different loop circuits. At the instant time a loop circuit detects the test vehicle, the start detection time jumps from zero to non-zero value. Repeated test data show that there were some inconsistent abnormal cases: the loops further away from the vehicle moving direction detected the vehicle earlier instead of later as shown in Fig. 8.4(b). This is absurd!

Besides, this situation is not speed-dependent. In about 20 time runs, there were 5 such abnormal cases. Such abnormal cases naturally cause serious problems when using start time for vehicle speed and distance estimation. The cause for the problem is not simply a sensitivity problem, because it is also not consistent. Further investigation for loop fault diagnosis is necessary to find out the real causes.

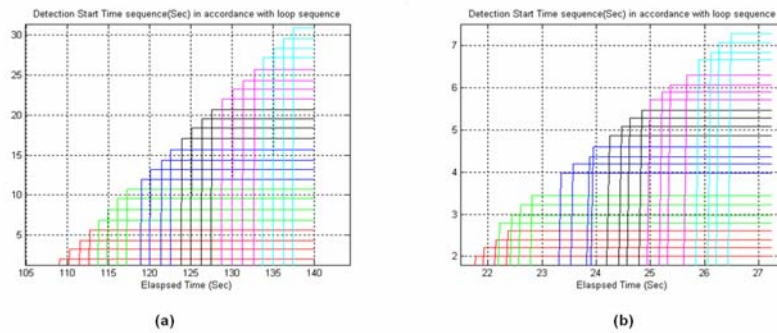

Figure 7.0.4 Start-time sequence versus loop sequence in vehicle moving direction: (a) Normal case; (b) Abnormal case – loops encountered later detected the vehicle earlier; vehicle speed: 30[mph]

7.3.2.2 Information Retrieval from Micro-loops: Presence Signal

To avoid the abnormal cases for the start of detection time, we have investigated the possibility of using lower level signals from the smart card – vehicle presence. The properly scaled and shifted presence signal sequence is shown in Fig. 8.5 for the 24 consecutive micro-loops. Similarly, different colors correspond to different loop cards. It appears that the presence signal does not show any prominent abnormal cases for the start of detection time.

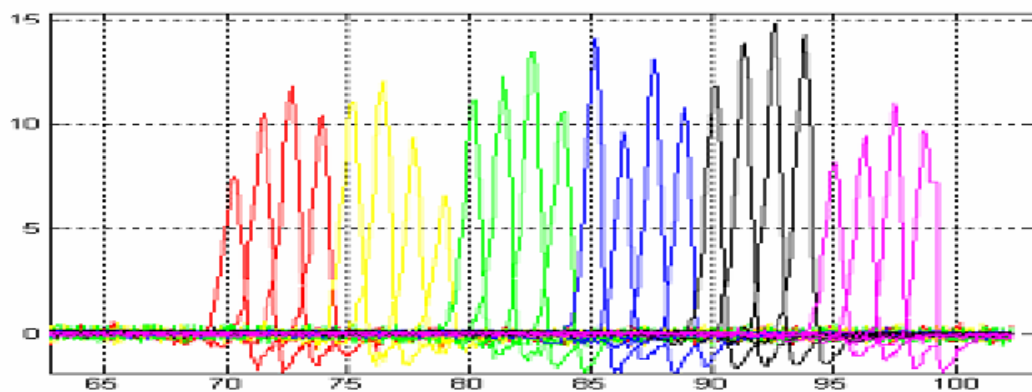

Figure 7.0.5 Typical presence signal, properly scaled

7.3.2.3 Loop Filtering and Estimation

There is a large and speed-dependent time delay in loop estimation: one cannot estimate the vehicle speed before the vehicle is detected by the second micro-loop. Besides, each loop has its own sensitivity. Each vehicle is a certain height. This height and the sensitivity directly affect the detection time and magnitude of the presence signal of a loop with respect to a vehicle.

Three methods are used for the estimation of vehicle speed based on the above two types of loop data: (a) Moving average, (b) Overall average, and (c) Kalman filtering. Due to a large time delay, speed variation, and internal dynamics of the model Kalman filter using vehicle kinematic model causes larger internal delays. Both a transient and static performance of a Kalman filter is not sufficient for real-time application, particularly when the vehicle speed changes. In the following, the other two simpler methods are discussed.

The first methods are used based on the following considerations:

- (i) The loop data is very noisy because the sensitivity of the loops is not homogeneous. For example, for the 24 micro-loops serially arranged along the direction of vehicle motion, even if the vehicle is running at almost constant speed, the distance for each loop to begin to catch the vehicle is different. Besides, this time instant is somewhat vehicle-speed-dependent. To achieve more precise estimation, extensive calibration for each loop is necessary to characterize the sensitivity. Then this loop-dependent sensitivity should be used to set up thresholds for each loop respectively.
- (ii) The time delay for speed estimation is significant: The distance between two micro-loops is 2.7[m]. Before the vehicle arrives at the second loop, there is no estimation of the speed. So the time delay is at least $2.7/v$ where v is the vehicle speed. The time delay and other factors cause large speed estimation errors.

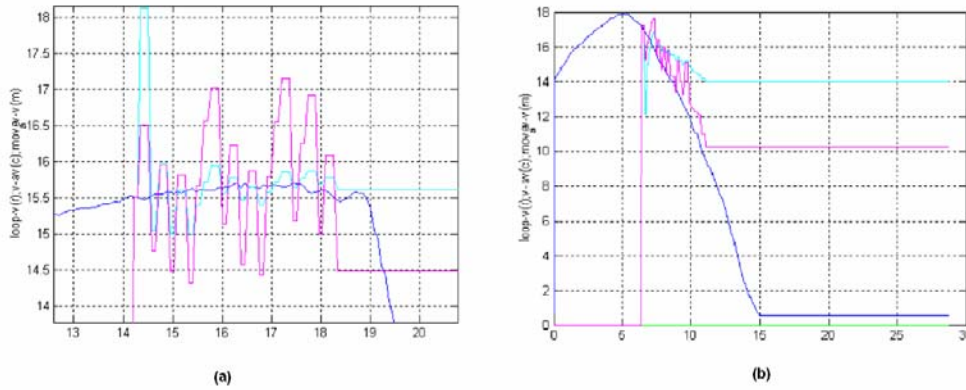

Figure 7.0.6 Speed estimation for two runs to show the effect of vehicle speed: blue = vehicle speed; cyan = average; magenta = moving average

It turns out that a 3 point moving average achieves better speed estimation for time-variant vehicle speed while the overall average is better for near-constant vehicle speed, which is in agreement with intuitive understanding.

We used the Kalman filtering approach to estimate vehicle speed and D2I. The following two types of vehicle dynamics models are used.

(1) 2nd order model:

$$\begin{cases} \hat{x}(k+1) = A(t)\hat{x}(k) + Bu \\ \hat{y}(k) = C\hat{x}(k) \end{cases}$$

$$A(t) = \begin{bmatrix} 1 & \Delta t \\ 0 & 1 \end{bmatrix} B = \begin{bmatrix} 1 & 1 \end{bmatrix} C = \begin{bmatrix} 1 & 0 \\ 0 & 1 \end{bmatrix}; u = 0$$

• Covariance: $Q = 10^{-2}$

$$R = \begin{bmatrix} 10^{-2} & 10^{-3} \\ 10^{-3} & 10^{-2} \end{bmatrix}$$

Assumptions for this approach are:

- The velocity difference between each detection instant is small, thus we can use the average velocity of preceding intervals as the current velocity measurement. (Actually, Δt and ΔV are not small enough for non-constant speed cases.)

Based on assumptions, the idea is to improve the convergence rate of speed estimates.

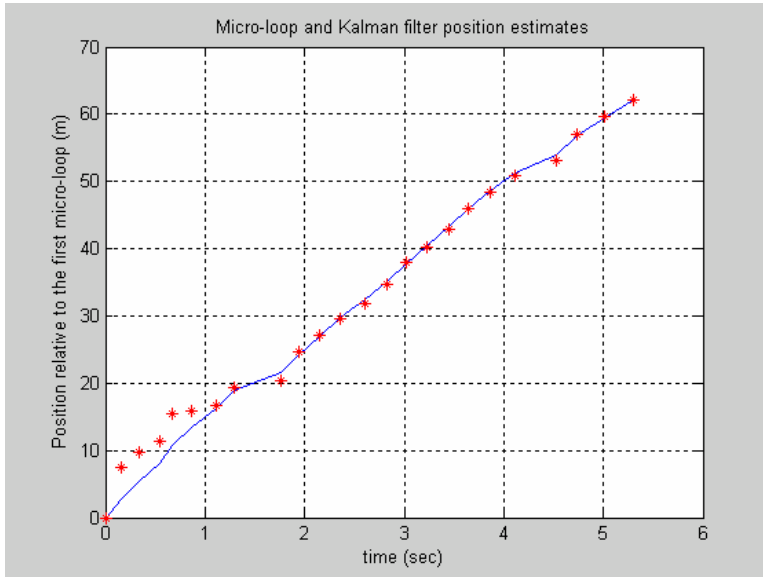

Figure 7.0.7 Kalman filter estimated D2I (line) versus micro-loop D2I (dots)

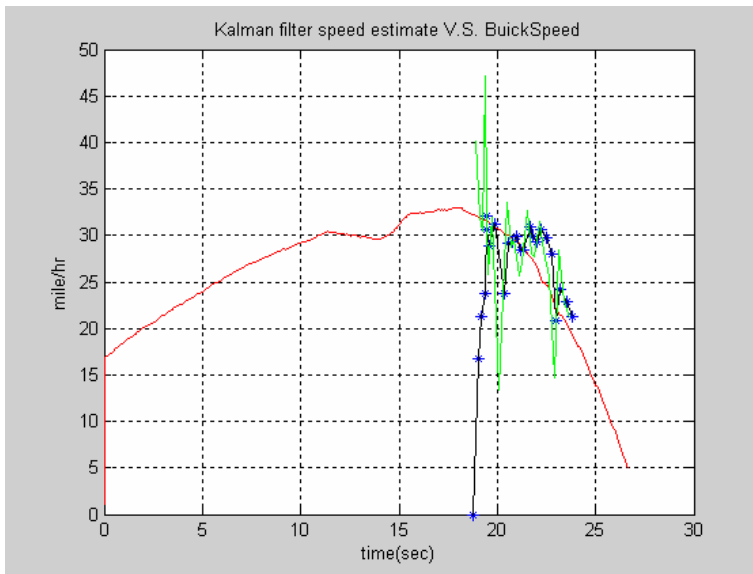

Figure 7.0.8 Kalman filter estimated speed (dots) versus wheel speed (line)

Position estimation is good enough for both constant and non-constant vehicle speed cases. Speed estimation has not been improved compared to other methods for both constant and non-constant speeds.

(2) 3rd order model:

- **Kalman filter:**

$$\begin{cases} \hat{\tilde{x}}(k+1) = A(t)\hat{\tilde{x}}(k) + Bu \\ \hat{y}(k) = C\hat{\tilde{x}}(k) \end{cases}$$

$$A(t) = \begin{bmatrix} 1 & \Delta t & \frac{1}{2}\Delta t^2 \\ 0 & 1 & \Delta t \\ 0 & 0 & 1 \end{bmatrix} B = [1 \quad 1 \quad 1] C = \begin{bmatrix} 1 & 0 & 0 \\ 0 & 1 & 0 \end{bmatrix}; u = 0$$

- **Covariance values:**

$$Q = 10^{-2} \quad R = \begin{bmatrix} 10^{-2} & 10^{-3} \\ 10^{-3} & 10^{-2} \end{bmatrix}$$

Simulations show that the results are qualitatively similar. Besides, several other covariance values are used for simulation; the results are also quantitatively similar. Theoretically, this method will not improve the estimation. Because only one measurement from micro-loop sensors is available, this additional measurement is also contaminated by the same noise. It is important to note that the time delay is significant: the first-step speed estimation cannot be conducted until the vehicle reaches the second loop. Such a time delay propagates along the vehicle driving path, which is the main difficulty for Kalman filtering. Besides, measurement from micro-loops is very noisy, which is another cause of large estimation errors.

7.3.3 Fusion of Micro-Loop Data and Radar Data

Because loops are radar, their detection capabilities are different. Some parts are complementary. The purpose of data fusion is to use their strengths and avoid their weaknesses. To achieve this the following fusion logic is used: if the radar has no detection while the loop has detection, use loop data; if the radar has reasonable detection while the loop does not, then use radar data; otherwise, a Kalman filtering approach may be used to assign appropriate weight to those two streams of data.

A static Kalman filter is used to fuse those two distance measures in normal cases [CHU]. The purpose of data fusion is to achieve a more reliable and accurate measure by means of sensor redundancy. (a) Using two distance estimates to compensate for each other's measurement to reduce target loss. (b) Using Kalman filtering properties to achieve an optimal estimation by assuming that the two measures from radar and loop sets are simultaneous and are independent [CHU, MAY].

Let $y_L(n)$, $y_R(n)$ denote loop and radar measurement in the longitudinal direction at time step n . Let $y_{LR}(n)$ denote the fused longitudinal distance of the target at time step n . Let $\bar{x}(n)$ denote the prediction variable. Then the Kalman filter for data fusion can be written as the following "predictor-corrector" form

$$\begin{aligned}\bar{x}(n) &= \frac{\sigma^2_{y_L}}{\sigma^2_{y_L} + \sigma^2_{y_R}} y_R(n) \\ y_{LR}(n) &= \bar{x}(n) + K(n)(y_L(n) - \bar{x}(n)) \\ K(n) &= \frac{\sigma^2_{y_R}}{\sigma^2_{y_L} + \sigma^2_{y_R}}\end{aligned}$$

where $K(n)$ is generally recognized as the gain of the corrector, and $\sigma^2_{y_L}$ and $\sigma^2_{y_R}$ are the variance of micro-loop estimate and radar longitudinal distance measurements, which are obtained by a comparison of the estimated value from measurement and those broadcasted by the test vehicle.

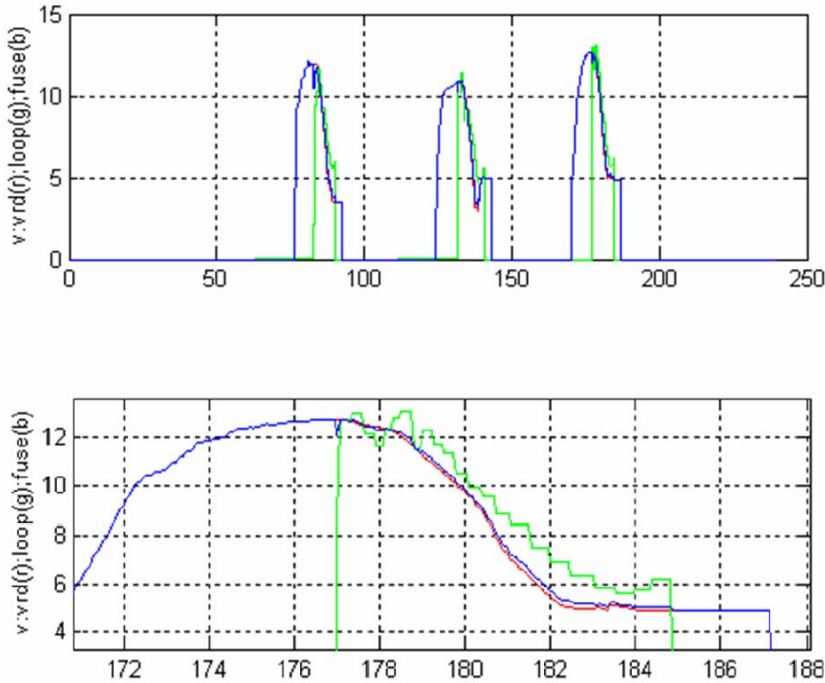

Figure 7.0.9 Fusion of loop and radar estimates. Upper: 3 consecutive runs; Lower: Zoomed 3rd speed peak. Colors: red = radar, green = moving average loop estimate, blue = fusion of two with larger weight on radar.

7.3.4 Fusion of Radar and Radio Data

To incorporate the information for vehicles, wireless communication is used to pass vehicle information, such as speed and running distance, to the control cabinet. The biggest advantage of using the vehicle information is that the control cabinet knows the vehicle is coming before the vehicle gets into the field of view of the radar system. The fusion of the vehicle speed and D2I with those detected from radar uses the same method, a static Kalman filter, as used for the fusion of micro-loops with radar detection. In Fig. 6.10, the radar does not detect the vehicle until it is about 100m away from the intersection. Information from communication is much earlier.

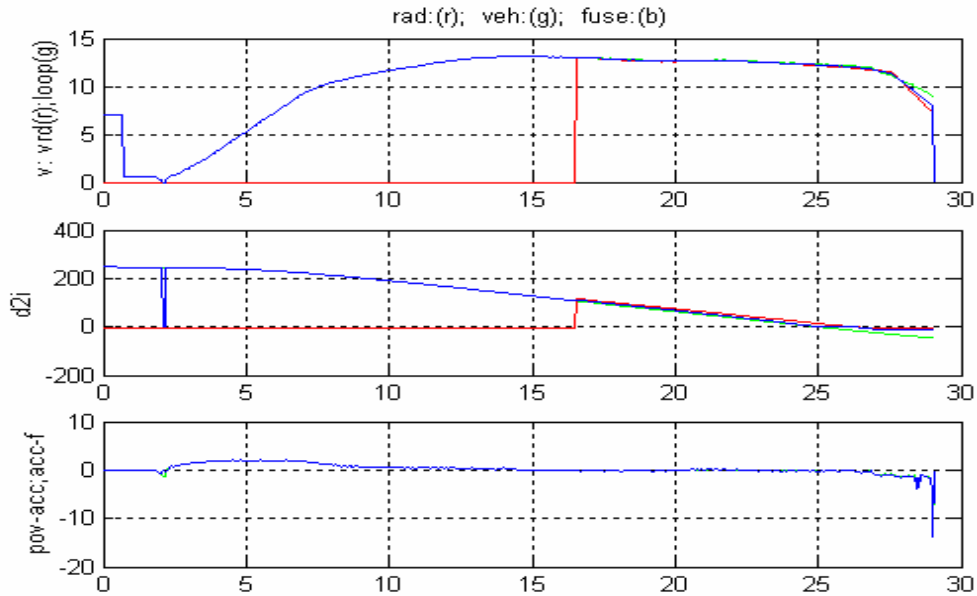

Figure 7.0.10 (1) Vehicle speed (Top) – estimated from micro-loops (green); measured by radar (red); and fusion of the two with the vehicle speed passed over by communication (blue); (2) D2I (Middle), the same fusion scenario as speed; (3) acceleration estimated (Lower);

7.4 CONCLUDING REMARKS

Eaton Vorad (EVT-300) Doppler radar and loops are used to detect vehicle speed, distance to intersection and acceleration estimation. It turns out that speed-based radar measurement and estimation are more accurate and have much less of a time delay than those from micro-loops, which is mainly caused by the time delays and measurement errors of the latter. Thus in data fusion, for moving vehicle speed and D2I estimation, much weight is put on the radar. Loops, on the other hand, are mainly used for static vehicle detection or in cases when the radar is missing targets for certain periods of time. This work also finds that both traditional loops and micro-loops are suitable for vehicle presence detection at a fixed point for traffic management where aggregated data is satisfactory. When time-critical estimation is necessary, radar is better than loops. Wireless communication provides vehicle information much earlier, which is an advantage for decision making at the intersection.

7.5 REFERENCES

[BAR] Bar-Shlom, Y, T. E. Frotmann, *Tracking and Data Association*, Academic Press INC, New York, 1988

[CHU] Chui, C. K. and Chen, G., 1999, *Kalman Filtering, with Real-Time Applications*, Third Edition, Springer, Berlin

[MAY] Maybeck, P. S., *Stochastic Models, Estimation, and Control*, **Vol. 1**, Academic Press, New York, 1979

[MOBUS] Mobus, R., A. Joos and U. Kolbe, Multi-target multi-object radar tracking, Proc. IEEE Intelligent Vehicles, IV-2003, 489-494

[WANG1] X. Q. Wang, W. B. Zhang, S. Johnston, D. Empey, C.-Y. Chan, Integrated multi-sensor-system: a tool for investigating approaches for transit frontal collision mitigation, 2001, ITS World Congress

8 COTS AND EMERGING TECHNOLOGIES: SENSOR TESTING AND EVALUATION

Project Task S Report

8.1 Introduction

This section addresses Task S of the Intersection Decision Support (IDS) project funded by Federal Highway Administration (FHWA) and Caltrans. The objective of Task S is to evaluate and select Commercially-Off-the-Shelf (COTS) and emerging technology products that could eventually be deployed at intersections as part of the IDS system. This report covers the COTS products that were identified and chosen as potential candidates by our research team for further in-depth evaluation and testing. The emphasis of this task is placed on sensing devices that can be used to monitor and track vehicle movement.

This report begins with defining the measures of effectiveness (MOEs) for COTS and emerging technologies. These requirements provide a framework of objective measures that allow us to identify applicable COTS and emerging technologies for IDS purposes. The sources that were used to perform a survey of existing COTS and emerging technologies follow. In addition to a literature survey, our survey also includes participation in a number of workshops and conferences at which different project personnel have actively searched for potential product candidates. The report then lists the most promising products that have been explored and identified as potential candidates. Next, we describe products that were chosen for further in-depth evaluation and testing and our subsequent experimental results. Finally, a summary of our findings and recommendations will conclude this report.

8.2 Measures of Effectiveness (MOEs)

In this section, we describe the guidelines for COTS product evaluation in the context of their applications for IDS. In addition, we provide a list of assumptions and constraints as well as the criteria that are used to define the measurement of effectiveness for COTS evaluations.

8.2.1 Background and General Guidelines

In designing and selecting sensors for an IDS application, we adopted the following general guidelines:

1. The fundamental sensing need for IDS application is to capture and estimate the states of subject vehicles (SV) and other vehicles (OV) such that potential conflicts can be accurately predicted.
2. For IDS applications, the requirements for detecting and tracking subject vehicles (SV) and other vehicles (OV) may be different if the intersection is not symmetrical.
3. Ideally, an IDS warning system should use as few sensors as possible to minimize the complexity of design and maintenance. However, depending on the application and the deployment site, a suite of sensors may be needed for obtaining the necessary coverage and achieving a high level of robustness. When multiple sensors are suggested as one sensor package, the overall costs (including materials, development, and maintenance) must be considered.
4. Sensor requirements are application-dependent and are often dictated by the operational scenarios (e.g., vehicle maneuvers to be measured and warnings to be issued) as well as the geometric characteristics of the implementation sites.

It should be noted, at the experimental stage of IDS we can choose to tolerate a wider range of reliabilities and inaccuracies since we set out to carry out the evaluation work in a controlled environment, our test facilities at PATH. However, for real-world implementation, a tighter and more rigid set of sensor requirements should be used based on the actual system specifications.

8.2.2 *Hypotheses and Assumptions*

Since IDS is in the research and development stage, we need to assume the following hypotheses at the initial stage to proceed with the COTS evaluation task:

1. The IDS applications are required to perform for situations where vehicles may be traveling up to 65 mph (105 km/h or 30 m/sec).
2. The closer the vehicle is to the intersection, the more critical the measurements of its motion.
3. The time window for warning and the required sensor range are dependent on the time needed for SV to make its maneuver, which in turn is a function of geometry and traffic patterns at the designated intersection.
4. Regardless of sensor types, a robust IDS application may require the estimation of time-to-intersection as well as distance-to-intersection to properly manage the activation and deactivation of warning devices. The data collected in Task B, field observation, appeared to confirm this hypothesis that drivers may use a combination of time and distance to make decisions for certain maneuvers at intersections.
5. A sensor needs to be capable of detecting stationary and continuously moving targets.

8.2.3 *Constraints and Limitations*

From the deployment perspective, we also realize that the following conditions will impose on the selection of sensors:

1. Even though sensor costs (including materials, development, and maintenance) should be balanced against performance, in the real world costs can be a dominant factor for agencies that deploy IDS. Therefore, in the process of selection and evaluation, availability, market share and unit cost ought to be considered.
2. A safety system may have its preferred choices of sensors, but alternative design or sensor strategies must be evaluated to accommodate the requirements of local regions or agencies. For example, it will be desirable to integrate existing in-pavement loop detectors or other traffic monitoring equipment existent at the deployment locations.

8.2.4 Evaluation Criteria

Sensors of different types and functionalities possess unique properties and characteristics; therefore the requirements should be defined accordingly. For the purpose of discussion, the following sections provide preliminary lists of criteria and guidelines for selecting both discrete and continuous sensors.

8.2.4.1 Discrete Sensors

This type of sensor detects the presence and potentially the speed of a target vehicle in a pre-determined location. The standard in-pavement loop detector is a good example. The minimum output of these sensors is a detection signal when an object is occupying the designated zone. Accompanying the basic functionality, some sensors may also yield outputs of occupancy ratio, vehicle counts, vehicle speed, etc.

A possible benchmark for evaluating discrete sensors is the commonly used in-pavement loop detectors. After the initial screening, the eligible products are evaluated with the following guidelines:

1. Unit cost and coverage area – evaluation by cost per lane or cost per area of detection, i.e. multi-lane detection by video image processing
2. Update rate and latency – total time delay on providing a signal to traffic controllers or microprocessors of choice should be minimized and more frequent update is strongly desirable.
3. Functional diversity – The ability for the sensor to be able to collect various types of data through the sensors. The types of data include: vehicle presence and passage, vehicle speed, and vehicle classification.
4. Accuracy – The accuracy requirements of any sensor components should be specified vigorously under the framework of an overall IDS solution, where an evaluation of system performance and fault tolerance design must also be incorporated.

5. Cost - For the outcome of the IDS project to be successfully implemented in a national scale, the cost of the components should be economically acceptable to the Federal, State and local entities that will use them. It is a goal of IDS to find components that are as economical as possible given they meet the functionality and safety requirements; emerging technologies devices are generally higher per unit than the COTS.
6. Vendor Cooperation - cooperation during the testing and specially modifying phases of this task will be considered as a de facto element of the evaluation process.

8.2.4.2 *Continuous Sensor*

This type of sensor measures the distance and speed of target vehicles over a defined coverage zone. Doppler radar and video monitoring systems for tracking the motion of a moving vehicle are examples that can serve the purposes of generating range and range rate measurements. This is an area where some candidates may come from commercial markets that are not traditional traffic monitoring devices, particularly in light of the more rigorous IDS sensing requirements, which are closer to requirements found in other applications. For example, radar and laser radar that are developed and produced for vehicle-based adaptive cruise control or collision warning systems can be potentially adopted for IDS applications.

The same type of criteria used for *discrete sensors* will also be applied to the continuous sensor category. However, an additional independent list of evaluation criteria will be necessary since the products that are to be evaluated may not serve traditional traffic monitoring functions. The suggested guidelines for initial screening are as follows:

1. Longer range preferred - the requirement of detection range for a particular application might be site specific.
2. The range of coverage that is needed for POV arrivals at the intersection depends on the speed of traffic approaching a specific intersection. For example, in order to issue timely turning alerts, the POV needs to be detected at least a desired time window, say 6 seconds, before SV reaching its stop bar. This means that in dense urban settings where

the speed of approaching traffic does not exceed 30 mph (~13 m/s), a coverage range of 80 meters from the stop bar could be adequate, but for higher-speed suburban and rural intersections, the coverage range may need to be as long as 150 meters from the stop bar. If the sensors are mounted on the far side of the intersection, the width of intersection and distance to stop bar need to be added to these range estimates. These could account for an additional 20 meters in the urban setting or 40 m in the suburban setting, leading to total sensor coverage range needs from 100 m to 200 m.

3. Capability for detecting stationary targets is essential for the SV approach to the intersection and in the intersection box.
4. Even though more critical POV targets are those that are moving at higher speeds toward the intersection, stationary POV should also be recognized and detected to offer a complete state map of the intersection to the IDS computer or processor.
5. Outputs of range and range rate (distance and speed) of individual vehicles are required - to predict vehicle trajectories and to provide threat assessment, range and range rate are necessary to estimate time of arrival.
6. Multiple simultaneous target detections preferred. The capability of sensing systems to track multiple vehicles is required for IDS solutions, to reduce device numbers.
7. Combined latency and update rate should be significantly less than one second - as mentioned above for discrete sensors, the final requirements for latency and update frequency is defined by the tolerance of warning timing, and is likely to be only a fraction of a second and the corresponding sensor latency and update rates will be more stringent than this initial threshold.
8. Errors of distance and speed measurements should be at least no greater than 8%; this number is based on a first-order approximation on the requirements of calculating of T2I, which is the time to intersection (Distance/Speed) of the target vehicle. As a first approximation, the cumulative error of $T2I = (\text{Error \% in Distance}) + (\text{Error \% in Speed})$. If we assume that T2I threshold of 6 seconds is critical (see assumptions in Section 2.2 above), then a cumulative 16% of 6 seconds gives us close to 1 second of tolerance. If the tolerance is smaller than one second, then the accuracy requirements should be adjusted downward accordingly.

9. Cost - For the outcome of the IDS project to be successfully implemented in a national scale, the cost of the components should be economically acceptable to the Federal, State and local entities that will use them. It is a goal of IDS to find components that are as economical as possible given they meet the functionality and safety requirements; emerging technologies devices are generally higher per unit than the COTS.
10. Vendor Cooperation - cooperation during the testing and specially modifying phases of this task will be considered as a de facto element of the evaluation process.

8.2.4.3 *Vehicle-Based Sensors*

This type of sensor is mounted on vehicles and provides vehicle state measurements. For example, GPS (Global Positioning System) and INS (Inertia Navigation System) devices are widely used for a variety of vehicle guidance and control applications. We will not cover this category in this document. We address them in our work with DaimlerChrysler in Tasks B and C.

8.3 Survey Sources

For this task, an exhaustive survey was conducted to identify the potential product candidates.

This survey included:

- Internet searches
- Trade Journals and magazine searches: Traffic Technology International and ITS international
- International Frequency Sensor Association online newsletter (<http://www.sensorsportal.com/>)
- An examination of the Vehicle Detector Clearinghouse (VDC) website (<http://www.nmsu.edu/~traffic/>)
- An examination of “Evaluation of Non-Intrusive Technologies for Traffic Detection-Final Report”, Minnesota Department of Transportation - Office of Traffic Engineer/ITS Section and SRF Consulting Group, Inc., September 2002. (Our evaluation goal is different from their goal in that we evaluated COTS specifically for their potential inclusion into IDS detection architecture whereas their evaluation of COTS was concerned with existing standard applications).

- TTI Workshop on Vehicle Detection, TexITE Meeting, College Station, Texas, June 22, 2000 (<http://transops.tamu.edu/content/sensors.cfm>)
- A review of a FHWA report by Virginia Tech: INTERSECTION DECISION SUPPORT- Task B, Top level requirements for an IDS system to mitigate scp crashes, Subtask b3: Summary of existing IDS technology, December 20, 2002
- Vendor discussions at the ITE's Annual Conference exhibit held in Irvine, California on March 28-31, 2004
- Vendor discussions at the ITS America Annual Conference exhibit held in San Antonio, Texas in May 2004

8.4 Reviewed Products

The following provides a list of all the candidate products that were surveyed and subsequently reviewed for their potential inclusion in IDS detection architecture. They are classified based on underlying vehicular detection technologies.

(Products chosen for further review are italicized.)

Microwave:

EVT-300 (Eaton-Vorad)
 SmartSensor (Wavetronix)
 AGD200 (AGD Systems)
 AGD302 (AGD Systems)
RTMS (EIS)
 New product (Optisoft)

Passive Infrared:

AGD440 (AGD Systems)

Video Image Processor:

CrossingGuard (Nestor Traffic Systems)
 VideoTrak (PEEK)
Vantage Video Detector (Iteris)
 Solo Pro II and Autoscope (Econolite)
Video Detection System (Traficon)

Active Magnetic:

SPVD-2 (Midian Electronics)

Passive Acoustic:

SAS-1 (Smartek Systems)

Active Laser:

LaserAce IM S (Measuring Devices)

Passive Magnetic:

VDS (Sensys)

Inductive:*Standard In-Pavement Loops*

3M Canoga Microloops

Selected products and their technologies and advantages are delineated in Table 8.1:

Table 8-1

Product Type	Vendor	Technology	Reasons Selected	Means of Acquisition
Canoga Microloops	3M	Inductive	Capable of continuous in-series detection; non-intrusive; insensitive to weather	Donation
Standard In-Pavement Loops	Many	Inductive	Widely used; capable of providing vehicle presence and volume	Purchased
Video Detection System	Traficon	Video image processing	Capable of providing presence, occupancy, speed and incident detection, non-intrusive	Loaned
Road Traffic Microwave Sensor (RTMS)	Electronic Integrated Systems (EIS)	Microwave	Capable of speed and presence measurements, non-intrusive	Loaned
VDS240	Sensys Networks, Inc.	Passive magnetic	Low cost; movability; capable of remote diagnostic testing; insensitive to weather, easy to install	Purchased (after it passed our preliminary performance requirements)

Products whose criteria were deemed not suitable for evaluation and testing for IDS are specified in the report submitted in September, 2004. In most cases, products not selected did not meet some of the most important evaluation criteria that were given in Section 2.4. In some cases,

lack of market penetration or lack of presence in the U.S. caused us not to select the manufacturer.

8.5 Experimental Facility – Intelligent Intersection at Richmond Field Station (RFS)

The RFS Intelligent Intersection was built with funds from the California Department of Transportation (Caltrans), and it was completed in 2003. The goal was to create a testbed to allow the University of California to conduct advanced traffic technology research in a designated and non-public location under controlled settings. Caltrans, with its associated research facilities on UC campuses, previously lacked a testbed to conduct experimental development of advanced traffic systems, e.g., intersection collision warning devices.

The RFS Intelligent Intersection is a four-legged intersection with one 12-foot lane per leg in each direction. The site is located at the intersection of Crow Drive and Owl Way of RFS. Crow Drive runs approximately east-west, and Owl Way runs approximately north-south. The intersection testbed is a four-way intersection:

- Westbound approach runs from Egret Way to the intersection on Crow Drive
- Southbound approach runs from the PATH test track to the intersection on Owl Way
- Eastbound approach is a very short segment from RFS Building 300 to the intersection on Crow Drive
- Northbound approach runs from Lark Drive to the intersection on Owl Way.

The intersection testbed is a unique facility in the Western United States. It has many distinctive features including a set of sensors using different technologies, the combination of an ITS 340 Cabinet and 2070 Controller, and a Driver-Infrastructure-Interface (DII) feature. Another useful feature of our testbed is the addition of an opaque fence along its westbound approach that effectively blocks the view of the drivers from the southbound approaching vehicles. This is intended to make the intersection look more like those in urban settings where structures may block the view of approaching drivers in most urban locations. The Canoga Microloops from 3M are installed longitudinally on the southbound approach whereas the traditional in-pavement loops are installed at three other approaches to the intersection. The normal set of four in-

pavement loops are installed on northbound and westbound approaches and a set of two in-pavement loops is installed on the eastbound approach (due to its very short length). Video detection systems from Traficon and Iteris are installed at the luminary mast arm observing the southbound approach. Also, the RTMS microwave radar is pointed at southbound traffic and is installed at a height of 18 ft. on another mast arm. A Sensys antenna is installed on top of the controller cabinet and can be turned to where Sensys nodes are placed in the vicinity of the intersection.

The RFS Intelligent Intersection is configurable to a certain degree: it can function as a signalized or non-signalized intersection by way of covering different components of traffic signs or signals.

Figure 8.1 shows our RFS Intelligent Intersection. It also includes a picture of the ITS-340 Cabinet with its components. A diagram of sensors installed at the intersection is shown in Figure 8.2. Finally, a diagram of detector cards is shown in Figure 8.3.





ITS-340 Cabinet

Figure 8.1 RFS Intelligent Intersection

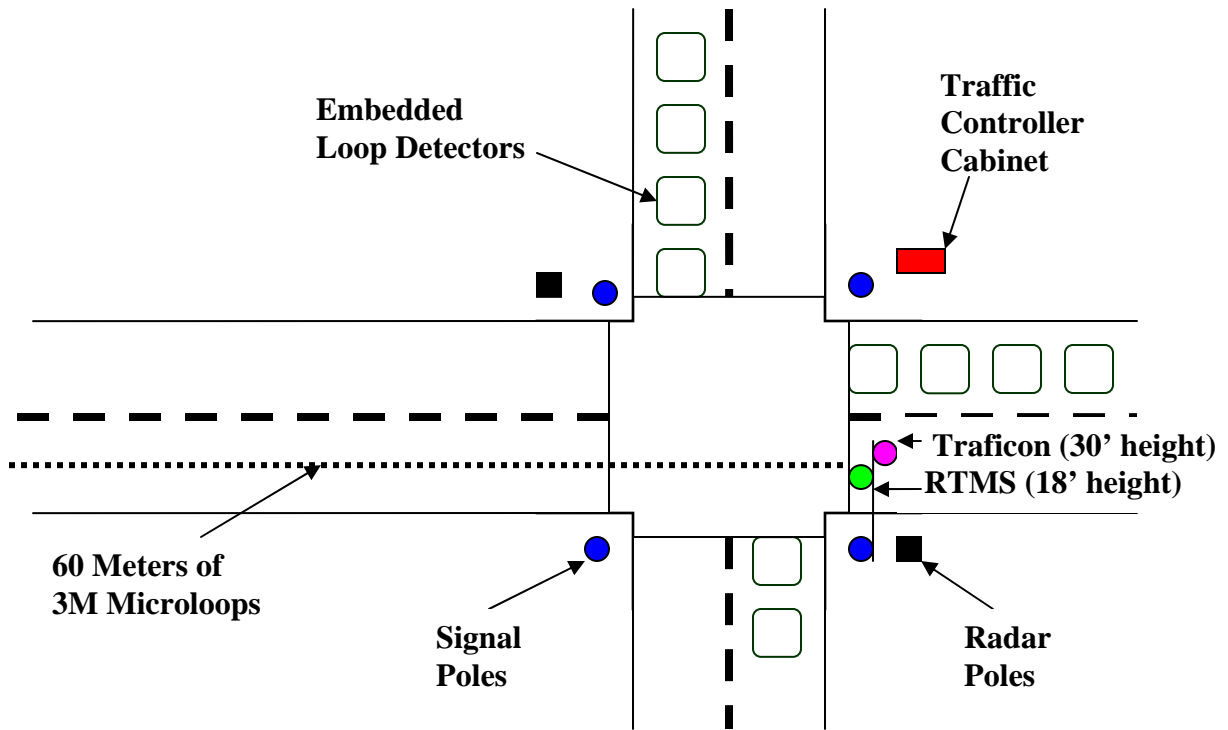

Figure 8.2 Diagram of Sensors at RFS Intelligent Intersection

RFS Intersection Loops, Microloops And Radar Placement

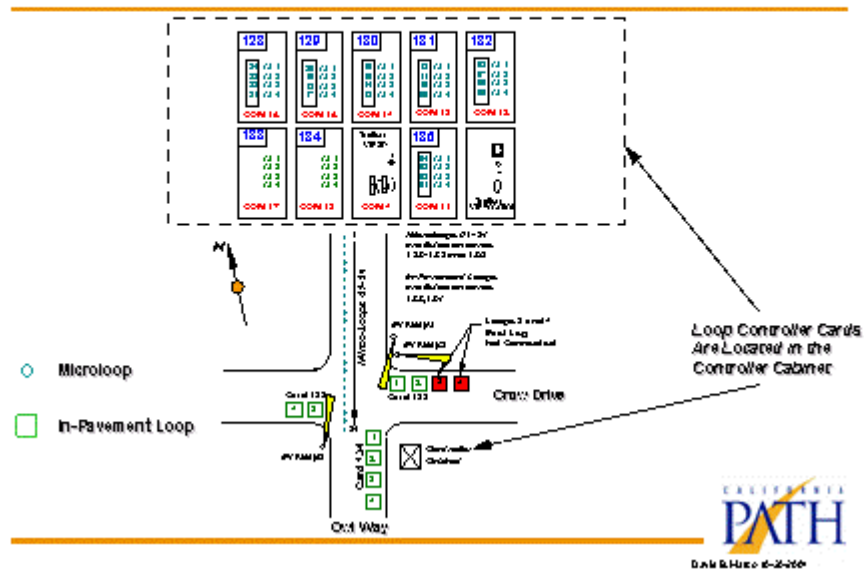

Figure 8.3 Diagram of Loops, Microloops and Radars at RFS Intelligent Intersection

The Cabinet: Hardware and Software

The RFS Intelligent Intersection is equipped with a 340-ITS cabinet (see Figure 9.2). This is a new and advanced cabinet. It was purchased from Eagle, a subsidiary of Siemens. The controller is an Eagle 2070. In this cabinet, we have also installed a PC104 computer running the QNX Neutrino real-time operating system to be used for data analysis and experiments with intersection decision support systems. The PC104 can communicate with vehicles and the RFS computer network wirelessly.

The combination of ITS-340 cabinet and 2070 controller is not yet fully supported by the Siemens software which runs on the 2070 controller. Although it is possible to program the 2070 using its front panel in the usual way to activate a signal call in response to loop presence information, it is not possible for our PC104 to use the NTCIP standard or any other communication mechanism operating through the 2070 to access the loop detector data.

There are nine 3M Canoga detector cards in the cabinet. These detector cards are used to detect the vehicles not only from the Canoga Microloops on the southbound approach but also from the standard in-pavement loops that are installed at three other approaches to intersection and other sensors. To acquire the information from Canoga Microloops to our PC104, we have written software that runs under QNX using the 3M Canoga Series C400/C800/C900E Serial Communication Protocol and have installed multi-port serial boards in the PC104.

8.6 Experimental Evaluation of Selected Products

In this section, we describe the products that were selected for evaluation and testing for IDS. It should be noted that IDS surveyed many COTS, but most failed to attract our initial interest due to their obvious limitations. In this section, each selected product is described briefly. Then, a discussion of experimental objectives, procedures, and findings are provided. The specifications of each product are attached in the appendix section.

8.6.1 3M Canoga Microloops

Product Description and Standard Use

The Canoga Microloops from 3M, in conjunction with Model 702 Microloops and the Canoga Vehicle Detector, are used to detect the presence and speed of vehicles. They are used mainly in freeways where they run underneath the surface at a depth of 0.45-0.60 meters, from the road surface to the centerline of their conduit, and across all freeway lanes. Given their placement, Microloops are unaffected by weather conditions.

The 3M Canoga Microloop were chosen for IDS evaluation and testing because they're capable of continuous detection of approaching vehicles as well as individual vehicles. Their primary advantage is the fact that they are not intrusive, as they can be installed, maintained, and repaired from the side of the freeway without any lane closures.

In our intersection testbed (see Figure 9.5), the 3M Canoga Microloops were first installed in a longitudinal manner in order to provide uninterrupted detection of approaching vehicles on the

southbound approach to the intersection. The length of Canoga Microloops installation is 70 meters and runs in a straight line from the mid-block of the southbound approach to the stop line of the northbound approach, thus running through the intersection itself. In our case, we used 24 Microloop probes, separated by about 2.75 meters or 9 feet each.

There are nine 3M Canoga detector cards in the cabinet. These detector cards are used to detect the vehicles not only from the Canoga Microloops on the southbound approach but also from the standard in-pavement loops that are installed at three other approaches to the intersection. To acquire the information from Canoga Microloops to our PC104, we wrote software that runs under QNX using the 3M Canoga Series C400/C800/C900E Serial Communication Protocol and installed multi-port serial boards in the PC104.

As mentioned, our Microloops were installed longitudinally; ordinarily 3M Canoga Microloops are installed latitudinally across multi-lane freeways to provide volume, occupancy and average speed.

Experimental Results

Test No. 1

Experiment conducted on: August 19, 2004

Weather conditions: Fair and sunny; dry conditions

Experimental objective: To determine the speed accuracy of 3M Canoga Microloops.

Experimental procedure:

On August 19, 2004 several PATH IDS team members and one Caltrans engineer conducted and observed an experiment to test the performance of the 3M Canoga Microloops installed longitudinally on an approach to the PATH testbed intersection.

The Microloops were numbered 1 to 24 from north to south (see Figure 8.4). Controller cards communicate with the Microloop probes by hard wires, with six controller cards controlling four probes each. Each card has its own independent system clock. These clocks drift over time. Clocks are used to obtain timestamp data, and the cards are reset sequentially with a script developed by the IDS team. The test vehicle, a Buick LeSabre, has automated throttle and

IDS used the collected data to compute the Buick's speed, assuming exact nine-foot spacing between each adjacent probe and then by using the detection times of adjacent probes. This was used, in turn, to calculate speed measurement error between two adjacent Microloop probes, using the Buick's tachometer as a reference value. The experimental results are shown in Figure 8.5 with the average percent error in speed measurement (between the values from the Buick vehicle and from the Microloops) for each run using all values and only values obtained by Microloop probes controlled by the same card (see Figure 8.5 [a = all, ico = inter-card omitted]).

Each controller card is capable of receiving four channels of inputs from four loops, and a total of six cards were used for the 24 loops. However, it was discovered that a discontinuity occurs due to signal transitions between cards. An additional measurement error was introduced if the last channel on a card and the first channel on the next card were used to estimate the speed of the vehicle passing between the two loops connected to these two channels.

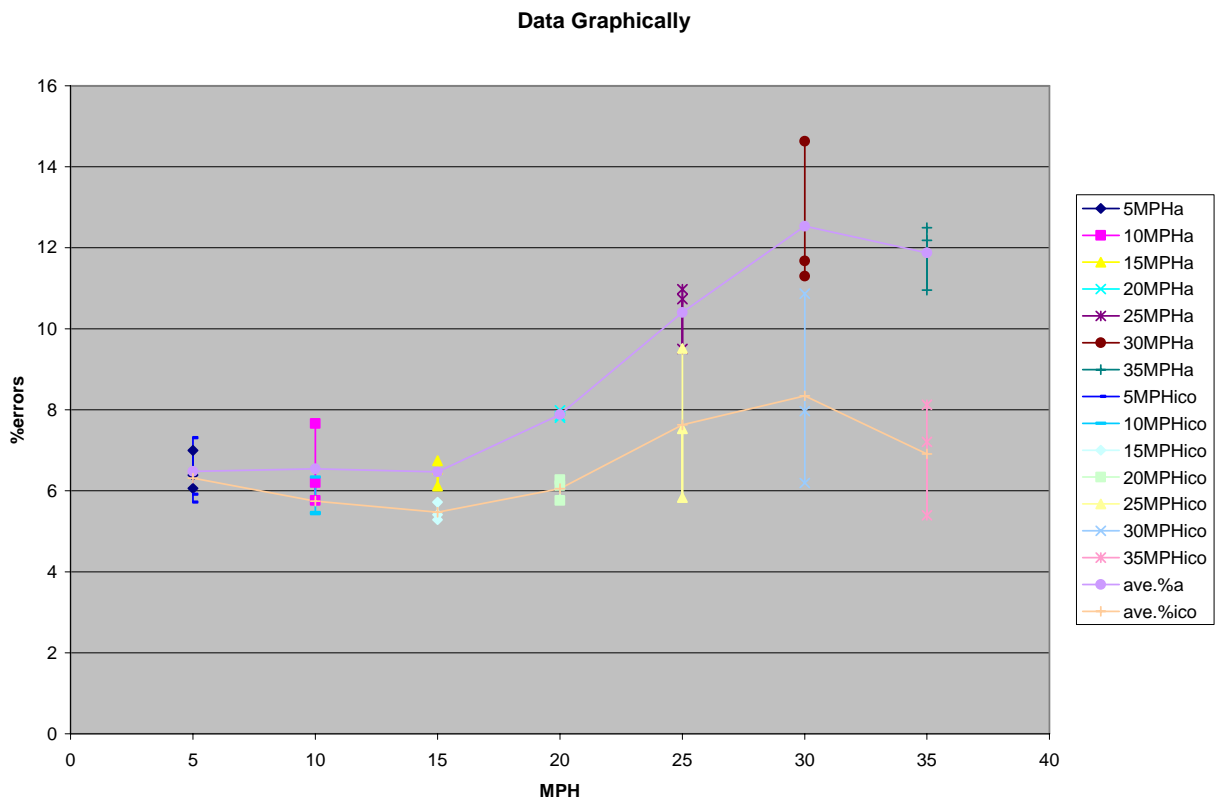

Figure 8.5 3M Canoga Microloops Graphical Data of Constant Speed

Experimental findings and future work:

A few general trends are noticeable: 1) factoring in data obtained by using two Microloop probes spanning a card boundary increases average error, and as a corollary this increase becomes more profound as time increases since the last card reset; 2) an increase in error exists when the test vehicle is not moving at constant speed; and 3) there is an increase in error with increasing speed above 15 mph.

The first trend makes sense: as the time after the last card reset grows longer, the card clocks drift away from one another, causing errors in speed calculations. Regarding the second and third trends, if the test vehicle accelerates, averaged data becomes less exact due to continuous change. If in the future the performance of next generation of Microloops improve and their percent errors for vehicles moving at constant decreases to an acceptable level for inclusion in IDS detection architecture, then we suggest that more acceleration and deceleration test runs should be performed to investigate the validity of the second trend mentioned above.

Test No. 2

Experiment conducted on: September 14, 2004

Weather conditions: Fair and sunny; dry conditions

Experimental objective: To determine the 3M Canoga Microloops' ability to accurately report variable speed and if it differs from constant speed.

Experimental procedure:

On September 14, 2004, the IDS team conducted a follow-up test of the 3M Canoga Microloops under vehicle acceleration and deceleration conditions. The hardware setup remained the same as the previous test runs, except that instead of using the Freewave wireless communication, 802.11b wireless was used. Three acceleration and three deceleration trials were run under manual throttle and steering. Once again, as this is a first investigation of variable speed, the sample size is small. The compiled data is presented graphically in Figure 8.6.

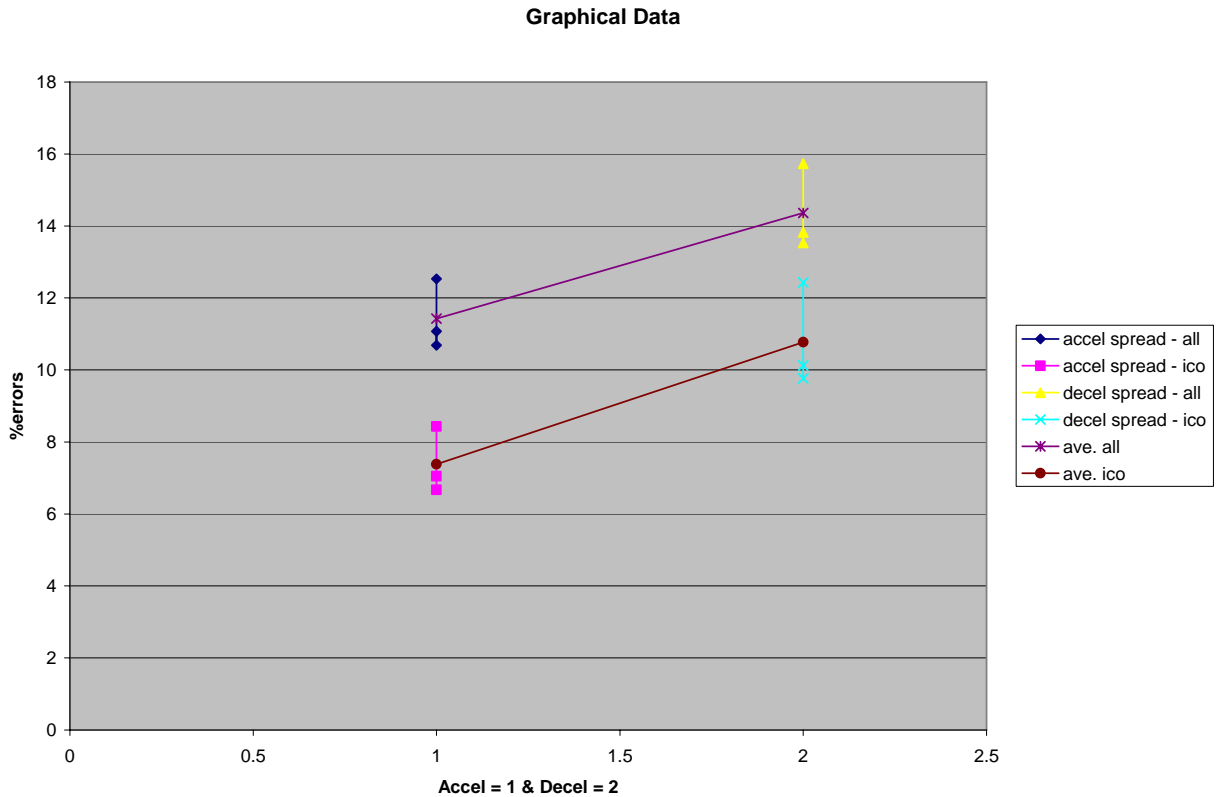

Figure 8.6 3M Canoga Microloops Graphical Data of Variable Speed

Experimental findings:

As expected and previously shown, there is a sizeable difference between using all data points and discarding the inter-card data (see test #1 for Microloops). The data leads to one interesting trend: the speed estimation from 3M Canoga Microloops appears generally better during vehicle acceleration, rather than deceleration. Also, the results of these few test runs supports the observation that we made in test #1 that the percent error seems to be lower if the vehicle is moving at constant speed.

A different way of examining the data yields the histogram in Figure 8.7, showing the frequency of both negative and positive residual values. The residual is calculated by subtracting the vehicle’s tachometer speed (our ground truth) from the intra-card, Microloop probes’ speed calculation.

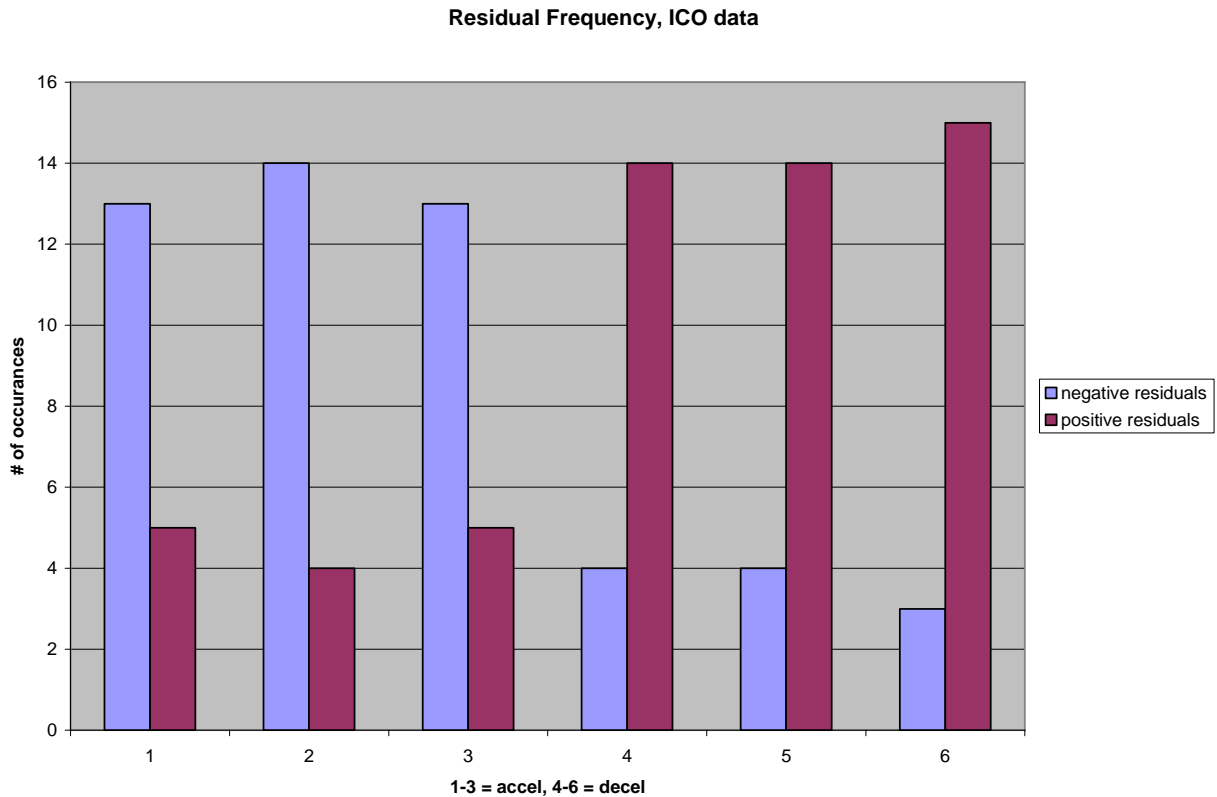

Figure 8.7 3M Canoga Microloops - Frequency of Positive and Negative Residuals

The data presented in this form points to a noticeably considerable (though not statistically significant, due to the small number of samples) underestimation of an accelerating vehicle's speed and corresponding overestimation of a decelerating vehicle's speed.

We are unable to account for the drop in percent error for the 35 mph run as opposed to the 30 mph run (see Figure 9.8) – in our controlled experiment, the only change was moving to manual steering, which should not affect velocity detection error, especially not beneficially. Further analysis to statistically establish the existence of estimation bias may also be conducted.

8.6.2 VDS240 (*Sensys*)

Product Description and Standard Use

The VDS sensors from Sensys Networks are discrete sensors with the added advantage of being moveable. Installation does not require cutting the pavement or providing electric power. These sensors use active magnetic technology to detect the vehicles. The system is comprised of sensor nodes glued to the pavement and an access point that collects information from the nodes. Each sensor node consists of a tiny sensor, microprocessor, and radio—all powered by a battery, and enclosed in a Bott's Dot. The access point contains a radio for communicating with the sensor nodes, a GPS receiver for clock synchronization and location, and a cellular or 802.11 radio for carrying the data or transmitting information to 802.11-equipped vehicles. The Sensys VDS240 is a coordinated wireless network: the access point is synchronized to that of the internal clocks of each of the wireless sensors. The Sensys VDS has a management capability to remotely diagnose and program the sensor network, which in turn minimizes the maintenance costs and traffic disruptions.



Figure 8.8 Sensys VDS240 Sensors on PATH Testbed

The Sensys VDS240 was selected for evaluation because compared with other available Commercially-Off-The-Shelf devices, the VDS sensors present a unique combination of extremely low cost of installation and maintenance, movability, remote diagnostic testing, and battery-powered capability, while remaining insensitive to adverse environmental conditions. An added advantage to acquiring these sensors is the fact that the company has offered a performance guarantee, agreeing to be compensated only if their equipment meets the IDS-required performance specifications.

The Sensys system's standard use cannot be cited as it is a new system and has not yet been deployed. Its intended use is to replace in-pavement loops and to provide vehicle volume, occupancy and speed.

Experimental Results

Experiment conducted on: September 22, 2004

Weather conditions: Fair and sunny; dry conditions

Experimental objective: To determine the ability of the Sensys VDS240 sensor to yield accurate speed.

Experimental procedure:

The Sensys VDS240 test was performed September 22, 2004. The results of this data analysis are a comparison of the velocity data from the automated (Buick LeSabre) vehicle versus the speed data collected from the Sensys Networks' VDS nodes installed on the pavement where the vehicle was running.

The automated vehicle is able to record its own wheel speed, global time and distance from point of software activation, among other parameters. The parameter of interest for this comparison was the actual vehicle speed at the location of 100.6 meters on the track. This is the point of location of the trailing node, which is the basis of comparison. The accuracy of the speed calculation obtained from VDS nodes is being compared to the internal wheel speed of the Buick.

The experiment was conducted at several speeds for two trials per specific speed. The speeds varied from 5 up to 35 mph. The test vehicle started at a distance of about 145 meters from the intersection, and passed over the VDS nodes at 100.6 meters from its initial starting point.

Experimental findings and future work:

From the results in Figure 8.9, it was noted that the vehicle calculations between the nodes and the internal speed were close. In general the percentage error between the calculations was, on average, between 0.3% and 6.9%. There was no clear indication of a pattern for the percentage error at any particular speed. In general, there was no trend of over or under-estimation in the error results.



Figure 8.9 Sensys VDS240 Node and Internal Speed Percentage Error

It is noted by the manufacturer that the Sensys VDS240 is unable to detect pedestrians, bikes and, in most instances, motorcycles. Sensys is also unable to detect multiple targets.

At the time of this writing, Sensys Networks has developed a new generation of Sensys products which is claimed by the manufacturer to be more reliable, capable of providing better measurements of speed and presence, resulting in overall higher performance. The new generation is also claimed to have a longer battery life and sturdier housing to protect it against damage and thus provide more operational durability.

Here are some claims of improvements by the manufacturer to the old generation of VDS240 that was tested:

1. New radio chips with multiple RF channels and better immunity to interference
2. Improved antenna design
3. Improved mechanical design for durability in-pavement
4. Improved battery life from one to two years in-pavement to more than five years
5. Enhanced detection accuracy
6. Implemented a Graphical User Interface that simplifies using the product
7. Introduced a high-end Access Point with cellular data backhaul for standalone operation

Based on the promising features of Sensys products, it is desirable to conduct additional tests if the COTS task is extended from the current IDS project to the next phase, the CICAS project.

8.7 Traficon Video Detection System

Product Description and Standard Use

Traficon's video camera's signal is used as input for the detection unit, consisting of a VIP/3 (Video Image Processor) board integrated into a standard 19" rack together with 1 communication board. The VIP board receives input from the camera's video signal. Detection zones that had been superimposed on the video image are activated when a vehicle crosses the zone. The detection is then registered in the appropriate position in the video image. Traficon's VIP uses the video images and corresponding algorithms to produce further data, such as traffic characteristics.



Figure 8.10 Traficon Video Camera at PATH RFS Intelligent Intersection

Traficon is typically used at intersections to provide presence, occupancy, speed and incident detection. They are positioned to monitor approaching traffic. Traficon was chosen for further study because it claims the ability to detect the presence of vehicles, a criterion required for IDS applications. It also claims to be capable of gauging vehicular speed.

The following, Figure 8.11, is a sketch of the four DATA DETECTION ZONES used in our experiments. The distances shown on the sketch is to the intersection's stop bar. It should be noted that the difference between the DATA DETECTION ZONES and PRESENCE DETECTION ZONES is in the fact that DATA zones give speed, whereas PRESENCE zones do not.

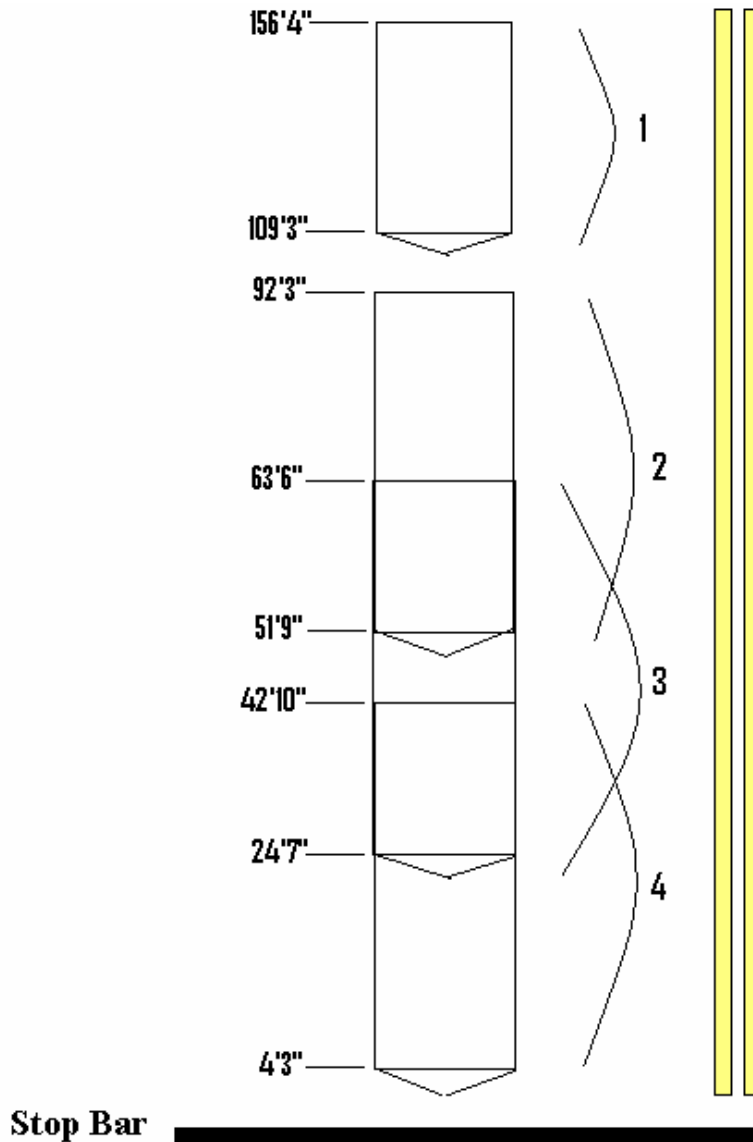

Figure 8.11 Sketch of Traffic Data Detection Zones

Experimental Results

PATH decided to test Traficon's accuracy under a varying weather conditions: stormy and rainy, which may impede accurate detection, and under fair and clear skies. Because it is hypothesized that stormy weather's wind and standing water may affect performance, we first let Traficon report detections with no passing car. We then staged two test runs with our automated Buick LeSabre under the polar weather conditions.

Test No. 1

Experiment conducted on: April 8, 2005

Weather conditions: Stormy conditions: heavy winds, overcast, rain

Experimental objective: To check Traficon's performance in stormy weather conditions, when it is hypothesized that Traficon would have trouble with correct detection. (Please see Figure 8.12 for an image of the PATH testbed with standing water, a possible impediment to accurate detection.)



Figure 8.12 PATH Testbed with Standing Water

Experimental procedure:

The IDS team collected raw data for five minutes under poor weather conditions in which no car was allowed to pass through this leg of the intersection where detection zones were set up.

Experimental findings:

Traficon repeatedly produced false detections. A graphical representation of these false positive detections per zone within a five-minute period is shown in Figure 8.13. At the time of this writing we are unable to verify whether Traficon’s inaccuracy may be due to the base shaking or high winds, but the high frequency of false detections proved Traficon unreliable in reporting accurate vehicle presence. It is worth noting that false detection was also observed in fair weather and under nominal lighting conditions.

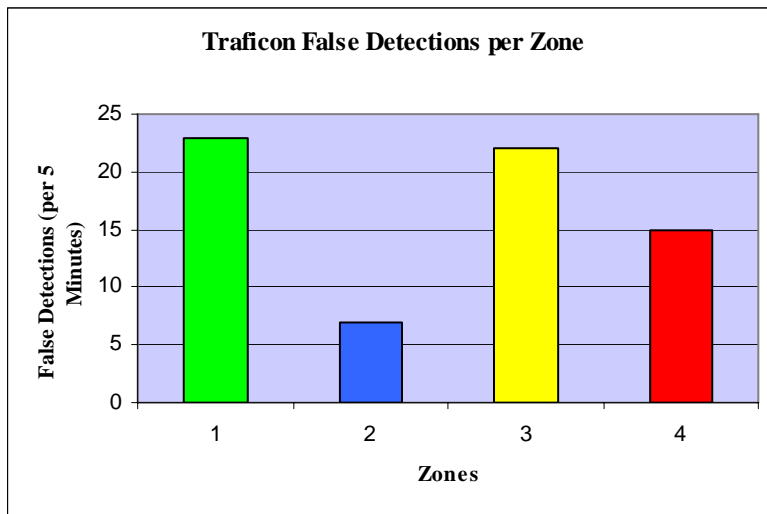

Figure 8.13 Traficon False Detections, Test #1

Test No. 2

Experiment conducted on: April 8, 2005

Weather conditions: Stormy conditions: heavy winds, overcast, rain

Experimental objective: To determine Traficon’s ability to accurately determine speed when the testbed has standing water due to stormy weather conditions.

Experimental procedure:

Nine runs were conducted in an instrumented Buick LeSabre at varying speed: 3 at 10 miles-per-hour, 3 at 20 miles-per-hour, and 3 at 30 miles-per-hour. The speeds reported by Traficon were then compared to the data collected in the instrumented vehicle.

Experimental findings:

Traficon reported both false positive detections (reported presence of a car that wasn't present) and false negative detections (didn't pick up the presence of a present car).

If Traficon were registering an accurate number of detections, it would produce four detections per run (one per zone). However, Traficon produced sometimes more and sometimes less than the expected four detections. Those numbers are represented graphically in Figure 8.14.

Mistaken detections occurred in different zones, and there was no pattern to which zone would yield more or less detections. An example of this inaccurate detection is shown in Figure 9.16. That figure shows that for our first run, in which the automated car was driving at 10 mph, Traficon generated 10 detections, when it should have produced only four. In this run, detection occurred most often in zone 1, but twice as often as predicted for zones 2, 3, and 4.

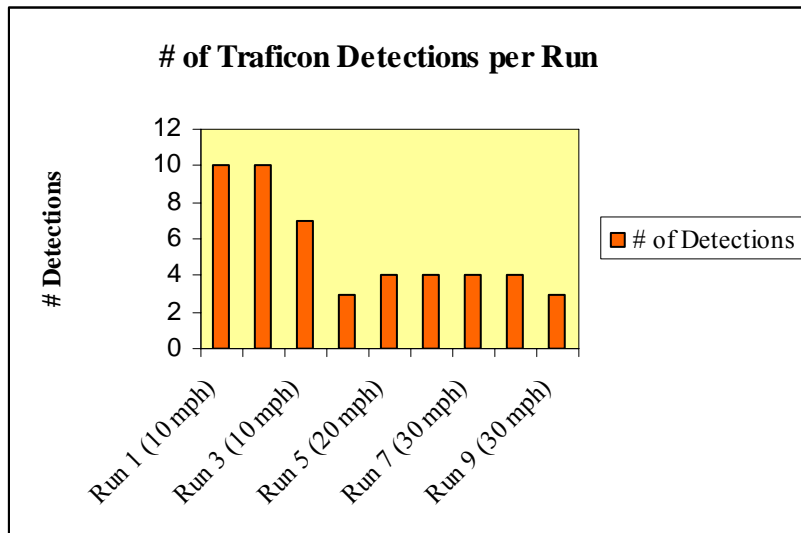

Figure 8.14 Traficon Detections per Run, Test #2

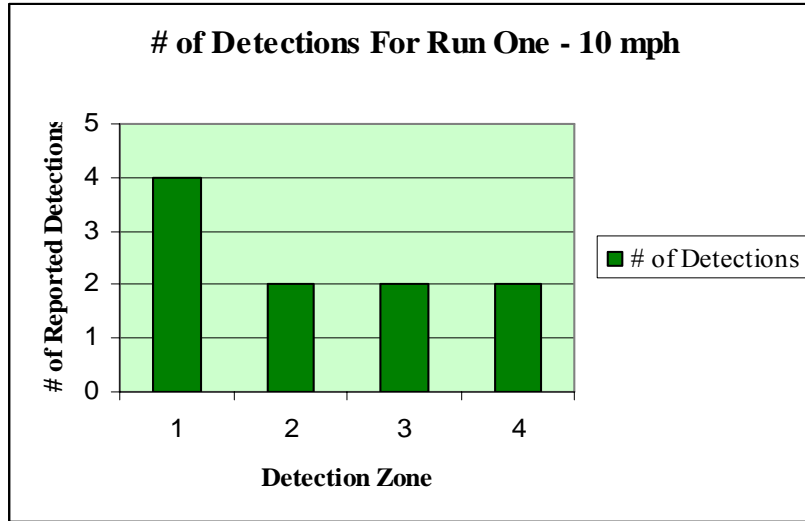

Figure 8.15 An Example of Traficon Detections per Run per Zone, Test #2

Test No. 3

Experiment conducted on: April 12, 2005

Weather conditions: Fair and sunny; dry conditions

Experimental objective: To determine Traficon’s accuracy in reporting presence and speed detection during ideal (sunny and fair) weather conditions. (Please see Figure 8.16 for an image of the PATH testbed during weather conditions conducive to accurate detection.)



Figure 8.16 PATH Testbed under Clear Skies

Experimental procedure:

Nine runs were conducted in an instrumented Buick LeSabre at varying speed: 3 at 10 miles-per-hour, 3 at 20 miles-per-hour, and 3 at 30 miles-per-hour. The speeds reported by Traficon were then compared to the data collected in the instrumented vehicle. The speeds given by EVT-300 radar are also shown in the following graphs to provide another source of comparison.

Experimental findings:

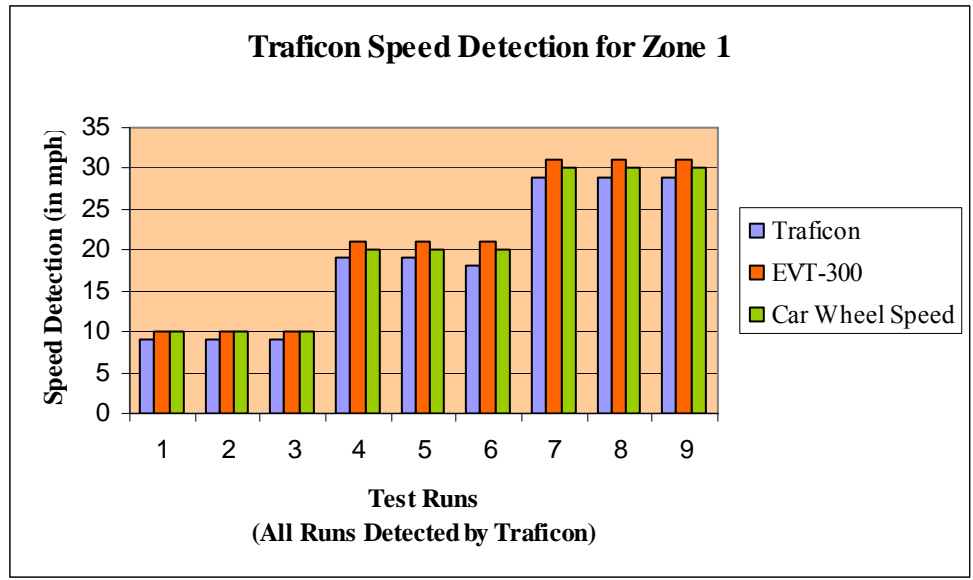

Figure 8.17 Traficon Speed Detection in Zone 1, Test #3

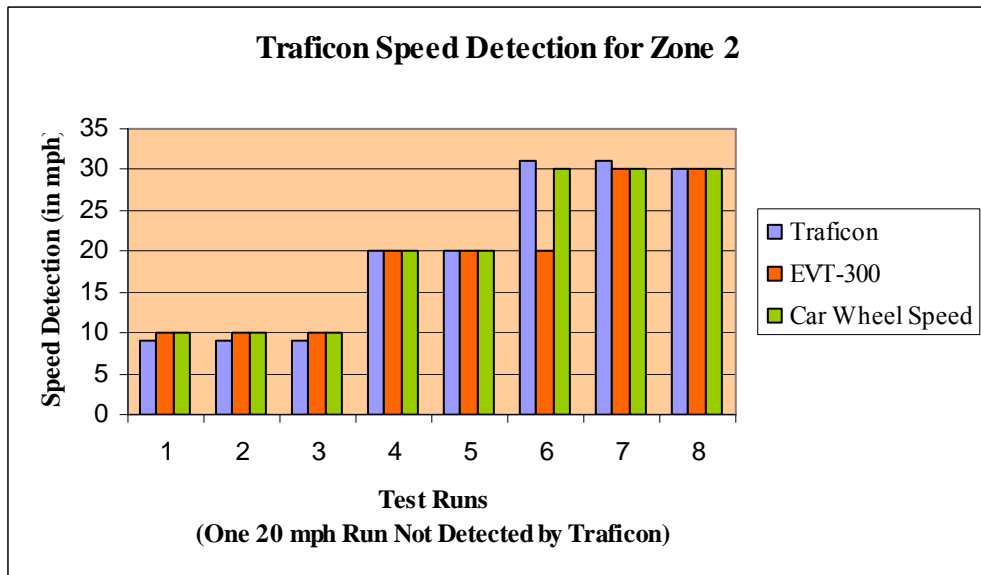

Figure 8.18 Traficon Speed Detection in Zone 2, Test #3

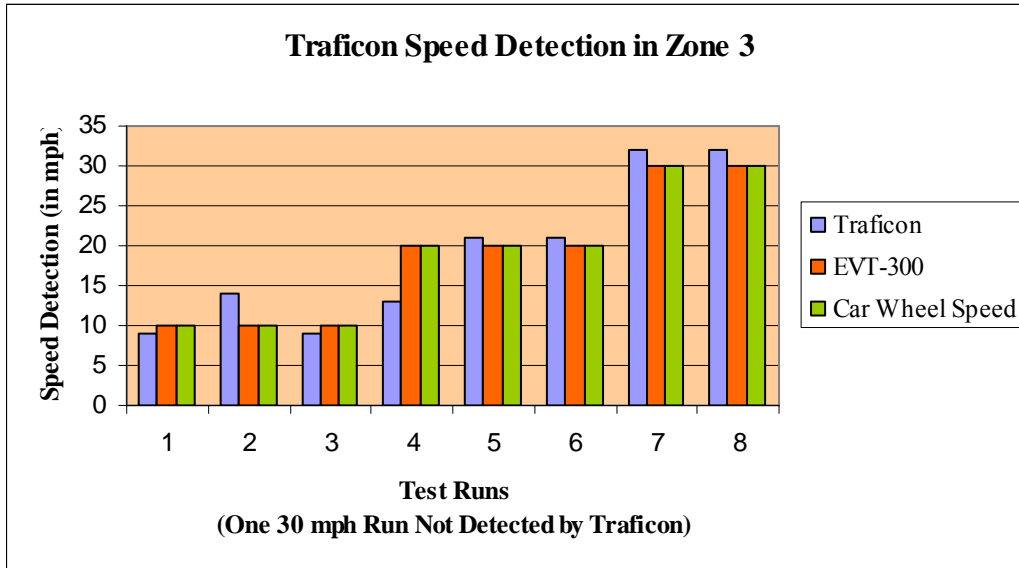

Figure 8.19 Traficon Speed Detection in Zone 3, Test #3

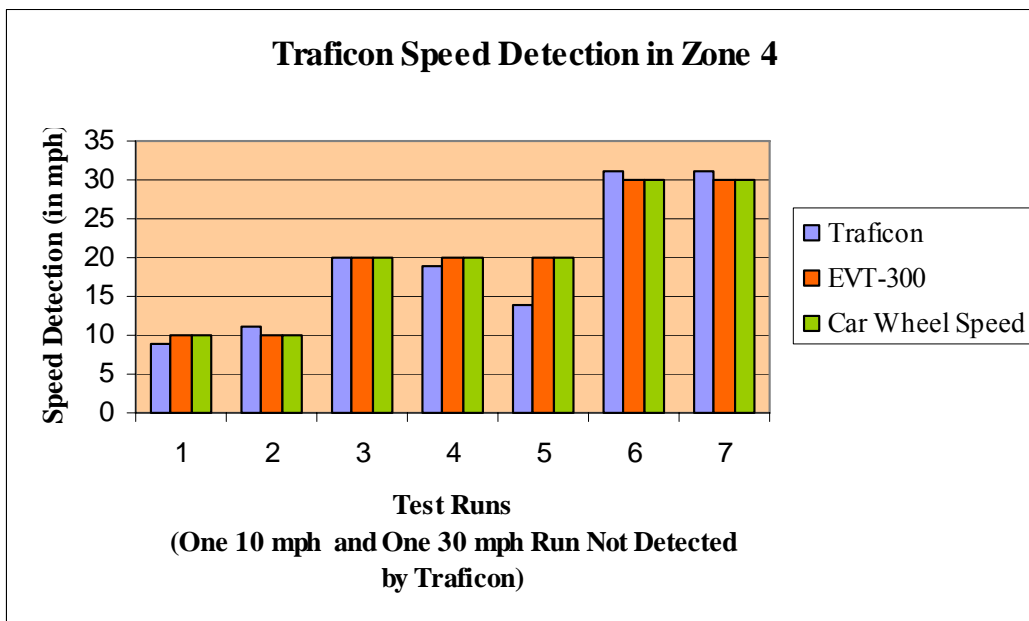

Figure 8.20 Traficon Speed Detection in Zone 4, Test #3

Traficon produced greater accuracy in detection in test #3 than in tests #1 and #2, when the weather was stormy and the testbed had standing water. Though Traficon proved more reliable

when the weather was clear and conducive to data collecting, its inaccuracy in detection under all weather conditions shows that Traficon is too unreliable to be further implemented.

The absolute percent error between Traficon and car wheel speeds is shown in Figure 8.21. The range of percent error is as low as 5% for zone 2 and as high as 15% for zone 3. The average percent error for all zones is 9%. These numbers were obtained after rounding out the speeds given to us by car wheel to the nearest integer. This is done for comparison purposes, and because Traficon also rounds out its speed values in the same manner before reporting them. For the smaller speeds, this will result in a less accurate comparison. If Traficon were to change its reporting method to provide speed reading at a higher resolution, we could make more use of their speeds in potential IDS detection algorithms.

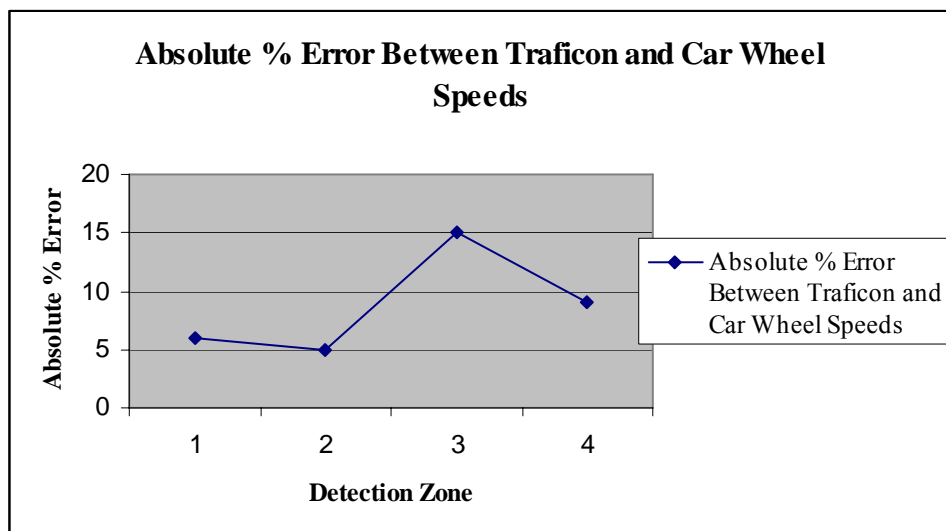

Figure 8.21 Absolute Percent Error between Traficon and Car Wheel Speed

Note:

Traffic engineers who have employed video detection systems in their jurisdictions have complained of false negatives due to shade and false positives resulting from the video detection's base shaking and standing water's light reflection²⁷. We observed these weaknesses in our own studies. These problems apply to Traficon, but are no doubt not unique to the Traficon video detection system.

The Traficon system is designed to work with a certain minimal level of traffic. In subsequent discussions with the vendor, it was pointed out that most false detections are the result of having only an infrequent handful of vehicles using the subject intersection.

8.8 RTMS (EIS)

Product Description and Standard Use

The Road Traffic Microwave Sensor (RTMS) by Electronic Integrated Systems (EIS) is able to detect the presence of vehicles in up to eight pre-selected zones. RTMS radar is also capable of tracking vehicle volume and average speed, as well as zone occupancy. RTMS is normally installed in side-fired configuration, in which it can gauge vehicular parameters when mounted on existing side-of-the-road poles. It is also deployable in the forward-looking configuration.





Figure 8.22 Road Traffic Microwave Sensor by Electronic Integrated Systems

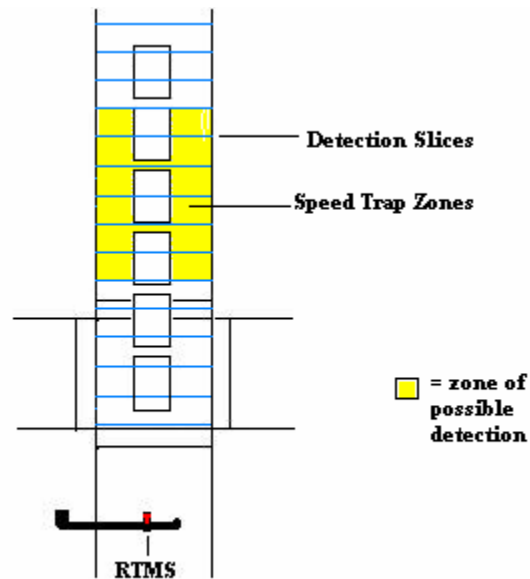

Figure 8.23 Sketch of RTMS Detection Zone at IDS Intelligent Intersection

The RTMS is a small radar device operating in the microwave band. Mounted on road-side poles, it is easy and safe to install and remove without traffic disruptions or lane closures. It is fully programmable to support a variety of applications, using simple intuitive software running on a Notebook PC.

The RTMS is most often used in freeways and urban areas with highly condensed traffic, where it has proven successful in side-fire tracking mass average speed and occupancy. The PATH study focused on its ability to track the speed and presence measurements of individual vehicles approaching the intersection. For this reason, the RTMS unit was installed in forward-looking configuration at a height of 18 ft. from the ground, at twenty degrees from horizontal, and at the center of the lane on a signal pole's mast arm.

Experimental Results

Experiment conducted on: April 5, 2005

Weather conditions: Fair and sunny; dry conditions

Experimental objective: PATH aimed to test the forward-looking RTMS sensor's capability to track an approaching vehicle's vehicle presence and speed.

Experimental procedure:

The PATH team performed 21 test runs using our instrumented Buick LeSabre with automated braking, steering, and throttle. The 21 test runs were: 3 at 5 miles-per-hour, 3 at 10 mph, 3 at 15 mph, 3 at 20 mph, 3 at 25 mph, 3 at 30 mph and 3 at 35 mph. The data reported by RTMS was then supposed to be compared to the data produced by the instrumented Buick.

Experimental findings:

The forward-looking RTMS divides its detection zone into 32 slices in which to detect the presence of passing cars. It also employs three speed trap zones that can be placed anywhere within its detection zone and then provide average lane speed data. The IDS team wrote a program to determine instantaneous speed using these 32 detection slices and the time that it takes for a passing vehicle to travel from one slice to the next. After preliminary analyses of the collected data and consequent discussion with the vendor, we learned that within these 32 slices, only six slices corresponding to three speed trap zones report the presence of the passing vehicle and not all 32 slices (see Figure 8.23). The RTMS calculates the average speed between two consecutive speed trap zones. This calculation is then extended for as many passing vehicles as

the radar picks up and then reported in bins where the length of each bin could be as little as 10 seconds.

We also learned that the RTMS cannot track the vehicles in its current version. It first uses Microwaves to pick up the presence of the target car within its detection zone. When the target car enters the speed trap zones, it becomes a Doppler radar which then provides average speed. The target car then leaves the speed trap zones and Microwave radar may pick up the target car's presence again, or loses it permanently. Furthermore, if there are multiple targets, the RTMS ignores the ones following the first target.

As a result, we determined that the RTMS is not capable of tracking individual vehicles, as far as speed and position are concerned. Also, even if all 32 slices were capable of simultaneous reporting, since the data is sent by RTMS every 225 milliseconds (the manufacturer's claim of 100 msec was never attained during the test at PATH), the actual speeds can't be calculated due to infrequency of the data reported. Our results then could not be used for data analysis, as they were too intermittent to be useful.

RTMS reports a vehicle's presence in 32 slices, where each slice is approximately 5.5 feet in length. There is no accurate way to determine where a car is in a slice. Rough estimates need to be used to post process a vehicle's speed. In order to more accurately calculate a vehicle's speed, much smaller slices would be needed. Currently RTMS reports at a rate of 225 ms. to calculate a vehicle's instantaneous speed appropriate for IDS applications, RTMS would need to report at a much faster rate.

8.9 Standard In-Pavement Loops

Product Description and Standard Use

The standard sensor for many years has been inductive loop detectors, which are loops of insulated wire installed beneath the surface of the road. Standard in-pavement loops can be used as a single point detector or a series of these detectors can be installed to provide detection for a length of road. They are also equipped to last many years if installed correctly, and are functional in all weather situations.

In-pavement loops have shortcomings of varying degree: they are difficult to maintain as repair instantiates ripping up the pavement and often road closures and they have a latency that may result in delayed information to the controller. The latency and subsequent detection inaccuracy may be mitigated by decreasing the space between consecutive loops, which would result in increased cost.

PATH chose to test standard in-pavement loops because they are currently in use at many intersections, and may be useful in conjunction with other sensors. The standard in-pavement loops are most often installed at intersections in order to provide presence and vehicle volume, at mid-blocks to provide presence and volume, and at freeways to provide presence, volume and speed.

Experimental Results

Experiment conducted on: March 7, 2005

Weather conditions: Fair and sunny; dry conditions

Primary experimental objective: To measure the latency of standard in-pavement loops

Secondary experimental objective: To investigate the effects of speed variation on loop latency

Latency of Standard In-Pavement Loop Detectors

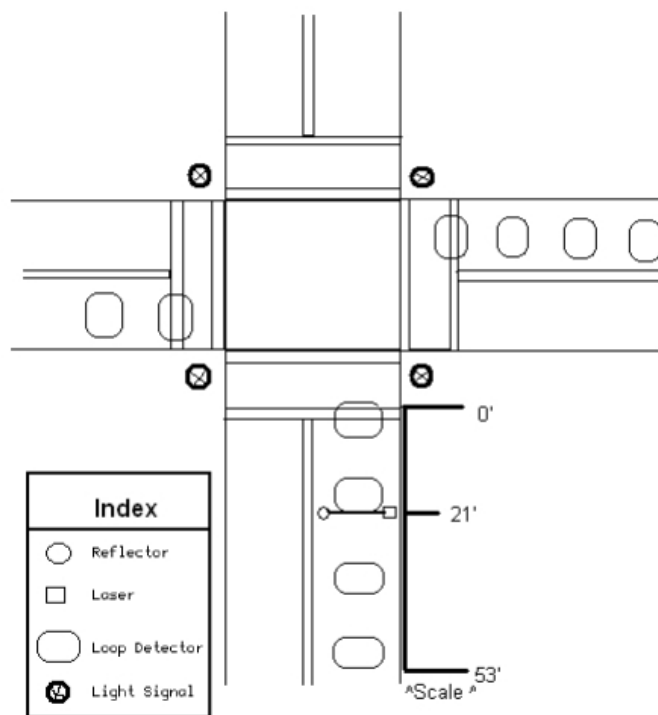

Figure 8.24 Diagram of Standard In-Pavement Loops in PATH Testbed

Experimental procedures:

This experiment aimed to measure the latency²⁸ of in-pavement loops, using vehicle test runs and a laser beam. Test runs were conducted by varying driving speed: speeds were increased per every three runs by five mile-per-hour increments, from five miles-per-hour to thirty-five miles-per-hour, totaling twenty-one test runs. A signal had been established between an infrared laser and a reflector placed on opposite sides of a standard-width lane (see Figure 9.25). The passing car then broke the laser beam. By recording the time it took for the controller to register the detection and the time that the test vehicle broke the laser beam and entered the loop area, latency was determined.

The experiment has a secondary objective to find out if there is a correlation between driving speed and latency. If a change exists in the results of our latency measurements, we may further hypothesize that a correlation exists between driving speed and latency of in-pavement loops.

Experimental findings and future work:

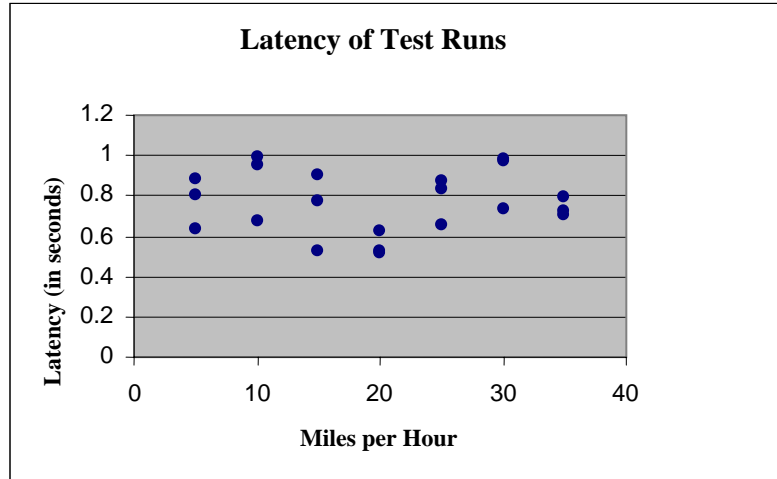

Figure 8.25 Standard In-Pavement Loops Cumulative Data Represented Graphically

For the IDS detection system, the most critical datum is the upper boundary in our resulting data (see Figure 8.26). The latency experienced by any sensor must be taken into account in IDS warning algorithms, since the generation and issuance of an alert signal will affect the perception and acceptance by the drivers.

Average latency of all test runs (in seconds): 0.765

Latency boundary values (highest to lowest, in seconds): 0.987 - 0.52

Speed (miles per hour)	Average Latency (in seconds)
5	0.774
10	0.871
15	0.732
20	0.558
25	0.786
30	0.894
35	0.74

Figure 8.26 Standard In-Pavement Loops Resulting Average Data

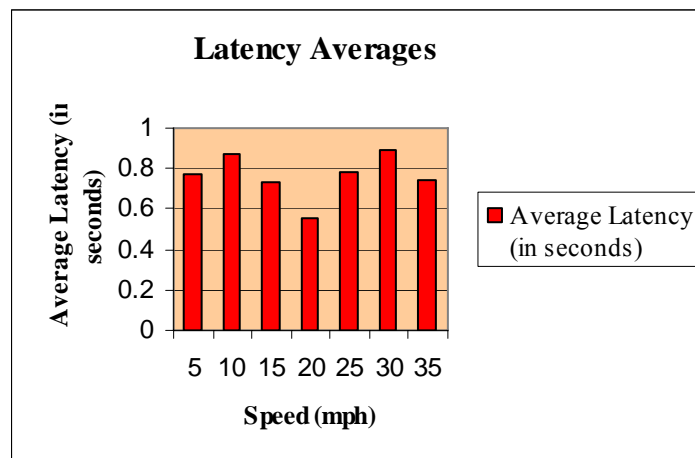

Figure 8.27 Standard In-Pavement Loops Data Represented Graphically

Our secondary objective hypothesis posits that vehicle speed may be correlated with loop latency but this has not been verified by this experiment. The results of our test runs using variable speed does not show a correlation or trend in latency versus vehicle speed (see Figure 8.25); more data would need to be collected to draw definite conclusions. However, we observed a temporal span of loop latency, including the highest value (0.987 seconds; see Figure 8.26), which is significant in the consideration for IDS applications.

More tests should be done to investigate the effects of moisture or water presence on the loop latency. Our experiment was done on a clean and dry day, whereas the presence of moisture or

water could potentially change the loop latency as it has been known through the experience of field engineers not to be as reliable a detector as they usually are in dry conditions.

Note:

It should be noted that a small time delay also exists in the reference measurement by the laser beam (optical switch). It is assumed that the time needed for the laser sensor to trigger and propagate the signal to the computer is minimal. An increase in the latency of the laser would result in a decreased latency calculation of the loop.

8.10 Summary and Recommendations

In summary, the PATH IDS team has found no single detection system that can, by itself, provide needed inputs for our warning algorithm. It is believed that a combination of different sensors need to be assembled together to provide a reliable detection system to be used in our warning algorithm. It should be noted that most COTS products are designed for conventional traffic monitoring purposes and therefore are not intended for the types of functionalities and specifications required by IDS applications.

As indicated in our report, different sensors using different detection technologies were investigated. We have tested a video-based system, Traficon, a microwave-based system, RTMS, a passive-magnetic system, Sensys VDS240, and inductive in-pavement loop detectors, 3M Canoga Microloops. We also investigated the latency of standard in-pavement loop detectors. Our findings of each experiment were given in the previous sections, but the following is a general summary of experiments along with recommendations for future work.

Based on the testing of **3M Canoga Microloops**, we discovered that the speed accuracy is not suitable for IDS applications. Also, the problem relating to clock synchronization of the detector cards and the data obtained by two Microloop probes spanning a detector card boundary increases the average error, and this error becomes more profound as time passes. It should be pointed out that 3M Canoga Microloops were originally designed for a different traffic monitoring applications and never intended to be used for IDS applications.

Sensys VDS240 was a promising emerging technology that we discovered during our survey. Its percent errors in speeds were below 7% during our experiments. This value is the best amongst all the systems that we evaluated, but even this system needs to be more accurate for lower speeds to be included in the IDS detection system. We plan to monitor the progress of the product developments at this front and conduct further testing when new generations of products become available.

For **Trafficon**, we performed three different studies. We were aware of some challenging issues related to any video-based detection system. Their system was not designed to track individual vehicles approaching the intersection, thus we put the system through a non-standard application. We discovered that there are frequent false positive and false negative signals, depending on weather and lighting conditions. We feel that this device is not suitable for IDS systems at its current state of development. The vendor has now better understanding of the requirements and expressed interests in further collaboration and developments.

We are planning to evaluate two more video-based systems at our Intelligent Intersection. One will be Vantage video by Iteris, which is already installed and is ready to be tested. The second is Autoscope by Econolite. The results of the continual testing will offer meaningful comparable results with those from Trafficon and other sensor products.

For **RTMS** radar, we were not able to perform speed comparison. The reasons for that are explained in the report. We discovered that the RTMS cannot provide tracking of individual vehicles, as we had originally hoped. It should be noted that the manufacturer has never claimed that RTMS, in its current state, can track individual vehicles. However, we tried to explore its output data to see if it can be used to calculate the speeds and track individual vehicles ourselves with additional processing codes. EIS, the RTMS manufacturer, is very cooperative with the IDS team and it is our hope that we can continue our collaboration with EIS to help with the next generation of the RTMS radars capable of tracking individual vehicles.

To the best of our knowledge, there has never been an experiment performed to measure the latency of **standard in-pavement loops** even though they are used extensively in the field. For this reason, the IDS team decided to devise an experiment to measure the latency of these loops.

The result is that their latency is about one second, in the worst case. This determination will be used in our warning algorithm as well as in our simulation efforts.

We will continue our survey, testing, and evaluation of COTS in the next phase of IDS under CICAS. We will continue to establish contacts with the COTS vendors and to communicate our IDS detection needs.

8.11 Acknowledgments

The IDS team would like to acknowledge the following companies and individuals who contributed to our Task S efforts:

3M Company, with their donation of 3M Microloops, and its employee Mr. Earl Hoekman, who was instrumental in the installation and calibration of Canoga Microloops.

Sensys Networks, Inc., and its founder Mr. Amine Haoui, with his support for our project. We also would like to express our gratitude to Professor Pravin Veraiya who introduced us to Sensys products.

Traficon and its United States technical support manager, Mr. Farid Semmahi, for their donated system and support for this project.

RTMS and its regional sales manager, Mr. Bill McDonald, as well as Mr. Andrew Thoms, and Team Andrews from its headquarters in Toronto, Canada, for their donated system and support for this project..

9 DESIGN OF ALERT CRITERIA FOR AN INTERSECTION DECISION SUPPORT (IDS) SYSTEM

9.1 IDS alert System design Considerations

The design of the IDS alert criteria needs to be based on consideration of a wide variety of issues which tend to make IDS more complicated than other types of advanced vehicle control and safety systems (AVCSS). These considerations are reviewed here; the specific alert criterion design is defined in the next section. The majority of these are human factors issues, discussed in Sections 1.1 through 1.9 below, while some are related to limitations of the technologies that must be used to implement the IDS, as set forth in Sections 10.1.9 through 10.1.12 below.

9.1.1 “Decision Support” Rather than “Warning”

The IDS system is being designed to provide “decision support” to the driver rather than an explicit warning of a specific imminent hazard. Because the intersection operating environment is so much more complicated than typical highway driving, it is not practical to define an unambiguous warning of imminent danger the way that forward collision warning or lane departure warning systems do. The intersection conflict is projected to occur if the driver proceeds directly into the turning maneuver, but the conflict will disappear if the driver stops or delays the turn. This is one of the main reasons that the IDS system has to be designed to provide advice to the driver (ranging from an implied “don’t turn now” to a more general indication of the closing of an available gap), rather than warning of a specific imminent hazard.

9.1.2 Suitability for Entire Driving Population

Most AVCSS have been designed for implementation within the vehicle, where their displays are only exposed to one driver at a time. In contrast, the IDS is meant to be centered in the transportation infrastructure, where it can be seen and used by the entire driving population. This approach has the advantage of being able to improve the safety of all drivers, not just those who have chosen to purchase a safety option on their vehicle (who would normally already be among the safer drivers on the road). Exposure to the entire driving population means that the

responses to the system are likely to be as diverse as the driving population. That population is remarkably diverse in its perceptual and response capabilities (visual, cognitive, and motor), acceptance of risk, impatience, etc., yet they must all respond to the same IDS display. This means that the alert-triggering criteria must represent a compromise across the population, meaning that the criteria will be “just right” for only a limited portion of the driving population, while having to be at least “acceptable” for essentially the entire driving population.

9.1.3 Need for Consistency with Current Gap Acceptance

The design of the LTAP/OD alerts should be consistent with current gap acceptance behavior among the general driving population. The large majority of left turn maneuvers is already safe, and crashes and near misses are rare enough events that they occur far out on the tails of the distributions of driving behavior. The IDS system should be designed to encourage drivers to avoid these more dangerous driving situations, without interfering with the majority of the turns that drivers make. If the system interferes with typical safe turning behavior, there is a significant risk that it will be judged as a nuisance by drivers. If this occurs, the drivers will be inclined to disregard the IDS alerts, even in those cases when the alerts could indeed help in avoiding a significant hazard, thereby undermining the effectiveness of the system. This need for consistency with current gap acceptance behavior leads to the need for significant data collection to quantify that behavior authoritatively.

9.1.4 Safety Considerations to Govern Minimum Acceptable Gaps

Since the purpose of the IDS system is to improve safety, it needs to alert drivers about inadequate gaps between oncoming vehicles for completing left turns. Obviously, crashes occur when the clearance between the SV and an oncoming POV reaches zero, but drivers are also likely to panic and take potentially unsafe corrective measures (maneuvers) for clearances that are larger than zero but still too small for comfort. Furthermore, the gaps need to be predicted far enough in advance of arrival at the conflict zone in the intersection that the SV driver can receive alerts from the IDS in time to abort or delay the turning maneuver.

9.1.5 Alert Criteria Considering Both Gap Size and When to Alert

The suitability of an LTAP/OD alert is governed by two different kinds of criteria. The first involves the identification of a large enough gap in the opposing traffic to enable the SV driver to comfortably complete the left turn maneuver. This gap may be defined in terms of the clearance (i.e., the physical distance between the rear end of a preceding POV and the front end of a following POV), or the time gap corresponding to that clearance, or both. The most meaningful use of distance and time to judge these gaps will be assessed by reviewing quantitative observational data describing current acceptance and rejection of gaps (6,7).

Once a gap is judged insufficient to make a safe turn and the alert threshold is met, the second criterion involves deciding the best time to display the alert to the SV driver, given that a gap is judged to be insufficient for making a safe turn. The alert needs to be early enough to give the driver time to perceive the sign that displays it, to understand its significance, and then to take action as needed (generally, braking to delay or avoid making the turn). At the same time, the display should not be activated so early that its meaning will be unclear to approaching SV drivers (“Is that alert intended for me or for another driver?”) or that it will be perceived to be equivalent to a nagging and overly cautious back-seat driver (“I can see that this gap is insufficient and I’ve already decided to forgo the turn as a result, so there’s no need to alert me about this!”).

These alert criteria are illustrated graphically in Figure 9.1, to help visualize the kind of trade-offs that need to be considered in system design. The alert system design characteristics need to be bounded by the shaded regions in the figure in order to be consistent with safe driving practices and with the expectations of the largest feasible proportion of the driving population. The specific numerical values associated with the boundaries in Figure 1 are in the process of being defined in the current research project, recognizing that these will not be universal values but are likely to vary from intersection to intersection and even by operating conditions at any individual intersection.

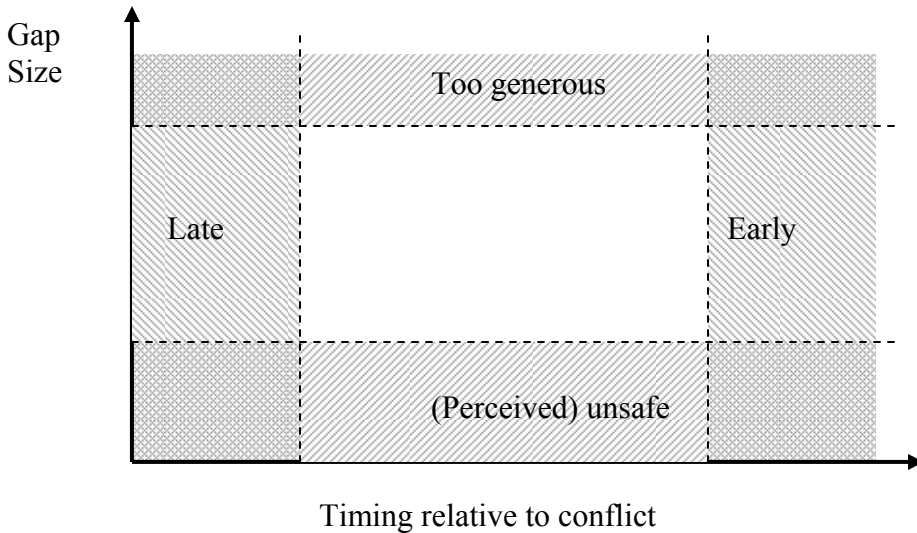

Figure 9.0.1 LTAP/OD Alert System Design Criteria

9.1.6 Subjectivity of Alert Criteria

There is no clearly-defined “correct” or “incorrect” alert for a potential LTAP/OD conflict, in contrast to alerts that address less ambiguous situations such as signal violations. A cautious driver with slow reaction time could consider a particular gap in opposing traffic to be insufficient for comfortably completing a left turn, while a more aggressive and faster-acting driver could consider the same gap to be generous for completing a turn. Regardless of the threshold gap size that is chosen as the alert criterion, some drivers will consider it too long and others will consider it too short.

The selection of the “best” time to display the alert to approaching drivers is subject to similar differences of opinion, with the slow-responding drivers considering an alert to be late while the impatient drivers could consider the same alert time to be so early that it is a nuisance because they have already decided about the adequacy of the gap in question. The alert design criteria need to be defined to satisfy the subjective judgments of a substantial majority of the driving population, but considerable testing of alert systems will be needed in order to verify that it is indeed possible to select criteria that will not simultaneously be too conservative for any but the most conservative drivers and too aggressive for any but the most aggressive drivers.

9.1.7 Determining When to Extinguish IDS Alert

Most safety warning system design issues are associated with the initiation of the alert, but the IDS design also needs to consider when to extinguish the alert. This is particularly important because the single infrastructure-based display is visible to all approaching drivers, not just the one at the head of the queue waiting to turn left. The identification of the SV that is being addressed by the display needs to be managed carefully to minimize ambiguities about the meaning of the display and also to minimize potentially confusing or distracting flickering on and off during the transitions from one SV to the next.

The relevant SV is generally the vehicle in the left lane (or left-turn pocket, if there is one) that is closest to the intersection. This vehicle remains most critical as the recipient of the alert while it is in the intersection but its driver is not yet fully committed to the timing of the turn. If the alert were to be extinguished too early (before a potentially threatening POV had crossed its path), this driver could be misled into thinking that the hazard had gone away and s/he might proceed to complete the turn despite the continuing hazard. The alert is no longer relevant to the driver of the first SV once s/he has committed to completing the turn, so at that time the next SV driver becomes the relevant target for the alert.

The transition to a new relevant SV may also mean that the potential conflict to be evaluated involves a different POV. The transition and potential for a future conflict need to be anticipated in the design of the alert criterion so that the display does not flicker off and then on again after a very short interval. If it appears that the alert threshold will be crossed again within a short period of time (e.g., less than 1 second), the display should be maintained rather than being extinguished and then re-illuminated (which could be annoying or confusing to drivers).

9.1.8 Long-Term Compatibility with Driver Behavior

The IDS alert needs to be designed to be compatible with driver behavior over the long term, including situations in which drivers may become habituated to use of the IDS system. It is important that drivers not be misled into unsafe encounters based on system malfunctions. For example, if the system were to be inoperative and therefore unable to provide an alert of an unsafe encounter, the habituated driver could interpret the absence of an alert as an implied

indication of a safe situation. In a situation like this, the IDS display may need to indicate that it is inoperative. Since IDS systems are only likely to be installed at a limited number of intersections that have particular safety problems, there should be less concern about drivers expecting IDS alerts at all intersections and responding inappropriately at unequipped intersections. Since intersections are already high-workload locations for drivers, care also needs to be taken in designing the IDS display to ensure that it makes minimal additional visual and cognitive demands on the drivers.

9.1.9 Influence of Traffic Signal Phase

The operation of an LTAP/OD alert should be closely coupled with the traffic signal cycle in order to be compatible with driver turning behavior. The “baseline” condition for design of the alert should be based on turns that are made in the middle of the green cycle, under steady traffic flow conditions. Variations should be incorporated for other parts of the signal cycle, based on a variety of considerations:

- for the last few seconds of the green cycle (“stale green”), slightly reduce the size of the gap assumed to be acceptable, to avoid discouraging SV drivers from completing their turns prior to the signal phase change (maybe: “to discourage SV drivers from attempting to complete their turns prior to the signal phase change?”), so that they are less likely to become stranded in the intersection, where they could be endangered by other vehicles;
- for the amber cycle, further reduce the size of the acceptable gap to encourage SV drivers to clear the intersection before the red phase;
- for the first few seconds of the red phase, further reduce the size of the acceptable gap to help SV drivers to clear the intersection rather than becoming trapped in the path of the crossing traffic who will have the green phase;
- during the remainder of the red phase, suppress the LTAP/OD alert display so that it is unambiguously clear that the red signal is the operative traffic control device;

- during the first few seconds of the green phase, activate the LTAP/OD alert if any POVs are present near the stop bar on the opposite side of the intersection, even if they are stopped, in order to discourage SV drivers from trying to turn ahead of them.

The magnitude of the adjustments suggested here will be defined on the basis of field observations of variations in gap acceptance with respect to the signal phase, and on the results of human factors experiments to elucidate drivers' responses to the various contemplated adjustments.

9.1.10 Need to Predict Future Vehicle Trajectories and Turning Movements

In order for the LTAP/OD alerts to be issued in time for turning drivers to take corrective action, it is necessary to predict the future vehicle conflicts that need to be avoided. This means that the trajectories of the vehicles approaching the intersection need to be measured and tracked with sufficient information to support predictions of future vehicle motions. At least the velocities of the approaching SV and POVs need to be measured so that their respective arrival times within the same portion of the intersection can be predicted. If either vehicle is accelerating or decelerating rather than cruising at constant speed, it will also be useful to measure or estimate these accelerations in order to produce reasonably accurate estimates of their intersection arrival times.

It would also be helpful to be able to predict vehicle turning movements so that the IDS advisories about the dangers of these turns can be reserved for drivers who are actually planning to turn. There is no need to give an LTAP/OD alert to an SV driver who is planning to drive straight through the intersection. If there is a separate left turn lane, it is reasonable to assume that any vehicle in that lane is preparing to turn left and should be advised about left-turn hazards. However, if left turns are made from a lane that is shared with straight-through traffic, the alerts would need to be provided for any vehicles using that lane. Given the limited use of turn signal indicators by today's drivers, the lack of a turn signal indicator could not even be used as a screening criterion to exempt through-traffic drivers from receiving the alert.

9.1.11 Influence of Intersection Geometry, Traffic and Weather Conditions

Intersections vary widely in the factors that can influence turning behavior and safety, and it is natural for drivers to expect IDS alerts to be tailored to each intersection's peculiarities, in the same way that drivers adjust their responses. A substantial program of data collection is needed to determine the precise quantitative influences on turning behavior of each intersection variation, so at this stage it is only possible to hypothesize the trends associated with each:

1. Wider intersections with more lanes of opposing traffic to cross, or intersections with stop bars set back further from the intersection, will need longer turning times;
2. Higher-speed approaching traffic places more stress on the turning decision of the SV driver, making it more difficult to judge the time available for completing the turn;
3. Wet or snowy weather or frozen road surface can reduce available traction for the turning SV driver, as well as braking traction available for the approaching POVs, requiring more conservative selection of traffic gaps for making turns;
4. Higher-density approaching POV traffic makes it more difficult for the SV driver to find a gap to use for turning, exerting pressure to accept shorter gaps in order to avoid being stuck for an additional signal cycle;
5. Higher pedestrian density increases the potential for conflicts with pedestrians in the destination crosswalk, requiring that these be incorporated directly into the alert criteria in order to avoid creating new hazards for vehicle-pedestrian conflict or reducing intersection capacity by making the turning criteria overly conservative.

9.1.12 Accommodating Limitations of Real Sensor Data

The simplest way of designing the IDS alert criteria is to assume the availability of complete and perfect information about the state of the intersection (signal cycle, as well as locations, speeds and accelerations of all approaching vehicles). However, it is clear that no sensor systems can provide this level of information, so the real imperfections of sensors will have to be

accommodated. One of the most challenging decisions in system design is selecting the minimum reasonable complement of sensors to provide information that is “good enough” to generate accurate and consistent alerts to drivers without becoming impractical or unaffordable. The sensor limitations that need to be addressed include:

- Availability of vehicle presence only at fixed location(s), without speed or acceleration (single loop sensor);
- Availability of vehicle presence and speed, only at fixed location(s), but without acceleration (double-trap loop sensor);
- Availability of vehicle presence and speed over part of their approach to the intersection, but without acceleration (video or radar sensors, but with insufficient range to cover entire approach);
- Challenges in sensing vehicle lengths and the presence and movements of pedestrians and bicyclists;
- Latencies associated with sensor sampling, signal processing and communication of data to the IDS computer;
- Noise and inaccuracies requiring significant filtering, which introduces additional delays before the information can be available for making decisions about alerting drivers;
- Sensor bias or drift errors, which can distort the information used to determine the threat posed by the turn and the need to alert the driver.

9.2 Design of IDS LTAP/OD Alert

The foregoing section identified the challenges to design of an IDS alert for reducing LTAP/OD conflicts. Regardless of these challenges, an initial design of an IDS alert has been created and tested in simulation. The logic underlying that alert is described here, with initial parameter values suggested. The values of these parameters will be adjusted based on the findings from several experiments that are currently in progress.

9.2.1 LTAP/OD Alert Logic

The logical flow behind the LTAP/OD alerts is summarized in Figure 9.2. The two main parallel branches in the logic address the motions of the SV and POV separately, since they are measured separately and are not too tightly coupled with each other. However, it is important to bear in mind that this logic is repeated at every measurement update interval during the intersection encounter (in the range of 75 to 100 ms), so that interactions between SV and POV motions can be captured within this relatively short time. The variables that are used in the alert logic are defined in the schematic intersection diagram of Figure 9.3.

The time for the SV to clear the intersection (and thereby remove itself from danger of being hit by an approaching POV) depends on specifics of the movements of the SV:

If SV is already stopped at the stop bar: $T2C = 3 \text{ s}$

If SV is stopped ahead of the stop bar, in the intersection: $T2C = 2 \text{ s}$

If SV is decelerating to stop at the stop bar (based on trajectory tracking estimation): $T2C = V_{sv}/\text{Decel} + 3 \text{ s}$

If SV is approaching the stop bar but not decelerating sufficiently to stop there: $T2C = (D2I_{sv} + D2C)/V_{sv}$

The numerical values of 2 and 3 seconds cited here are based on preliminary observations at the initial intersection selected for data collection (5), but it is fully expected that these will be intersection-specific adjustable parameters for future IDS implementations. In particular, it will be necessary to account for the distances between the respective stop bars of the approaching SV and POV and the location where these vehicles could actually come into contact with each other.

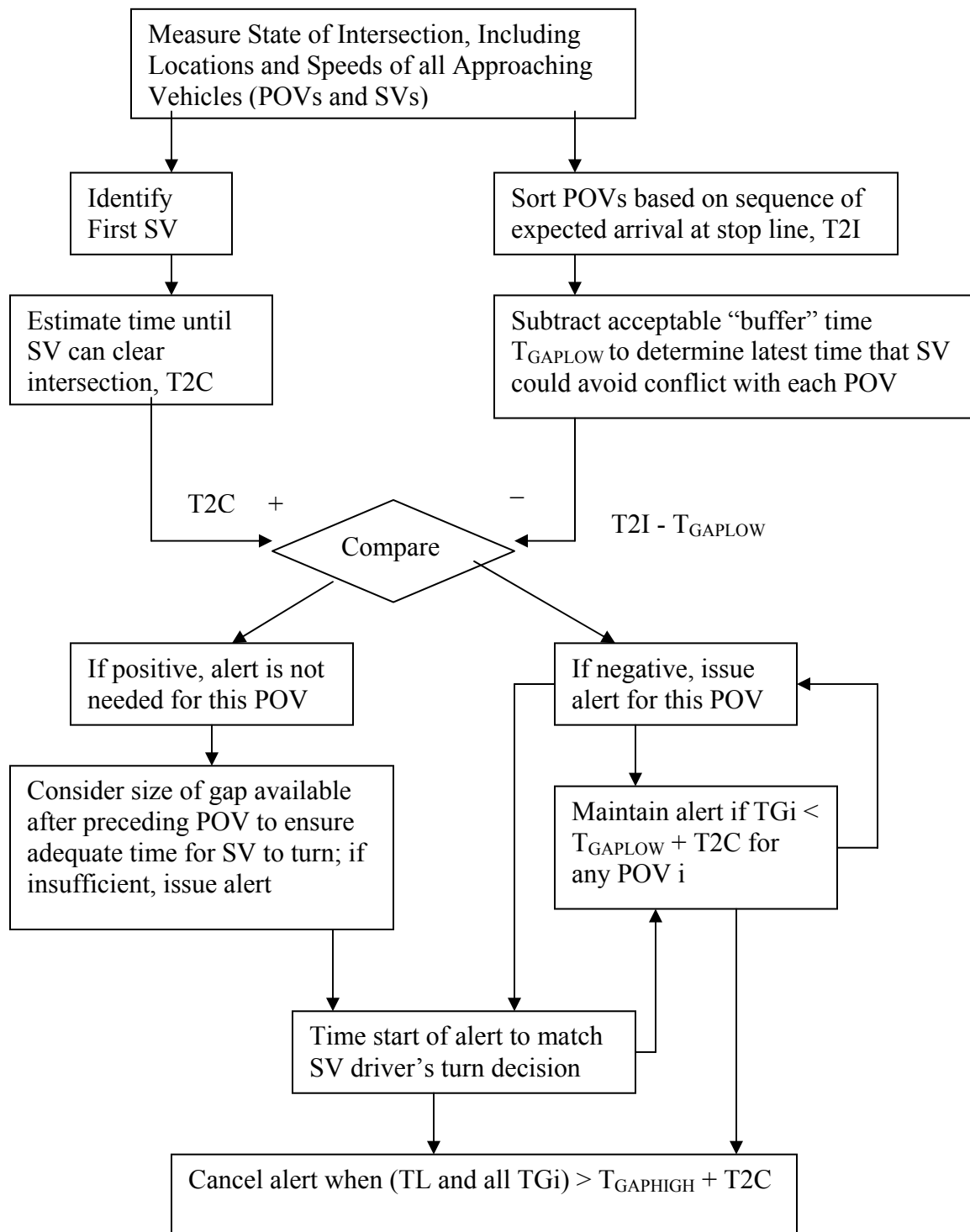

Figure 9.0.2 Logical Flow of LTAP/OD Alert

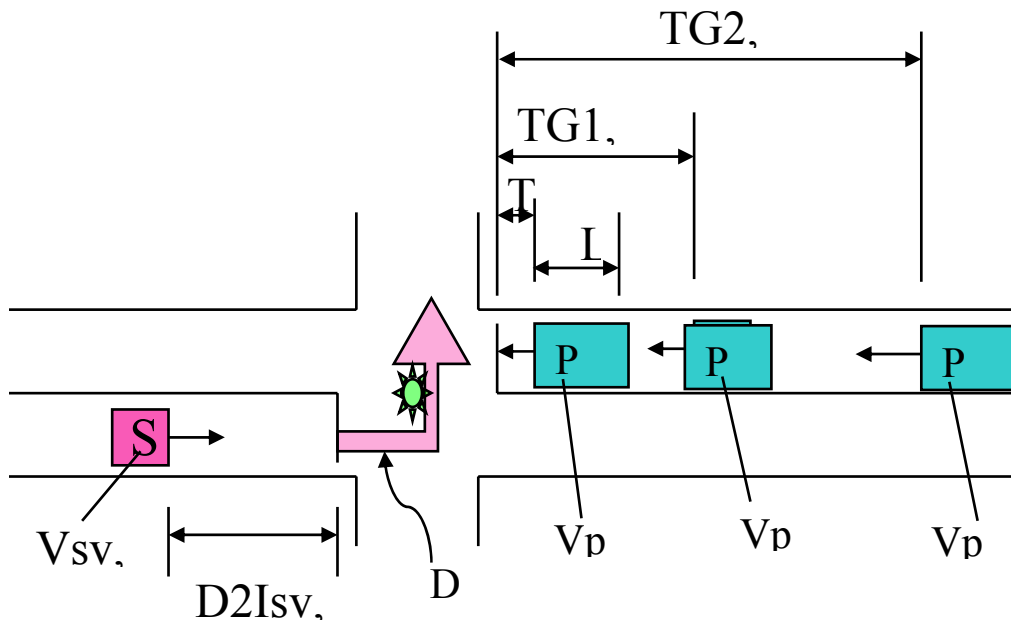

Figure 9.0.3 *Definitions of Variables Used for Alert Criteria*

$D2C$ = Distance from SV stop bar to location where SV clears path of approaching POVs
 $D2I, T2I$ = Distance and time to arrive at intersection stop bar
 TL = lag time before arrival of POV_1 at stop bar
 TG_i = gap time to arrival of POV_{i+1} at stop bar
 V_x = vehicle x approach speed
 $Decel$ = deceleration rate of SV
 L = length of preceding POV

The arrival times of the POVs at their stop bar must be predicted based on the available information about their locations and speeds, updated sufficiently frequently to deal with speed changes. Since the SV could be in conflict with any of the approaching POVs, its $T2C$ needs to be compared with the arrival times of each of the approaching POVs, and the acceptable “buffer” time between the SV’s clearing of the intersection and the arrival of each POV needs to be subtracted from the POV arrival times to determine the suitability of each of these gaps for the turning maneuver. If there is not expected to be a sufficient buffer time behind the SV (if $T2C < T2I_{POV_n} - T_{GAPLOW}$), then the alert should be issued for a potential conflict with POV_n . This alert should be maintained if the gaps between subsequent POVs are insufficient to permit the turn to be completed. These gaps need to be estimated based on clearing the rear of the preceding POV,

so if the POV length, L , is not known by direct measurement a value still needs to be assumed for it.

$$\text{Gap1} = \text{TG1} - \text{TL} - L/V_{\text{pov1}}$$

$$\text{Gap2} = \text{TG2} - \text{TG1} - L/V_{\text{pov2}}, \text{ or more generally,}$$

$$\text{Gapi} = \text{TGi} - \text{TGi-1} - L/V_{\text{povi}}.$$

In addition, the alert criterion needs to consider the acceptable separation between the rear of a POV that has just cleared the intersection and the front of the SV that is making the turn. This case is not as serious from the safety perspective because it is much easier for the SV driver to perceive the passage of the POV, and the POV is heading away from the SV rather than toward it. Nevertheless, the IDS should alert the SV driver to not initiate the turn so early that it might pass too close to the rear of the passing POV (with rear buffer threshold values expected to be in the range of 1 to 2 seconds, pending analyses of detailed observational data on these gaps).

The comparison with arrival times of individual POVs is not sufficient to address all of the potential impediments to completing the turn. In addition, it is necessary to ascertain whether there is a sufficient gap between consecutive POVs to accommodate the turning maneuver and the buffer times that the SV driver needs before and after its traversal of the intersection. For example, if POV_n is arriving before the SV, it would not be considered a hazard, and if POV_{n+1} is arriving at least T_{GAPLOW} after the SV, it would also not be considered a hazard. However, the gap between these two POVs may still be insufficient to accommodate the turn, especially if POV_n is long, such as a bus or truck.

The alert should be terminated when the gaps between the SV turning time and the arrival times of all remaining POVs exceed T_{GAPHIGH} . This value is larger than T_{GAPLOW} (perhaps by about 1 second) in order to provide a hysteresis effect, so that the alerts do not flicker on and off when the gaps vary slightly around a crisp threshold value.

Once it is determined that an alert should be issued to discourage a potentially unsafe turn by an SV driver, the timing of the initiation of that alert needs to be defined based on the best estimate

that can be made of the time when that SV driver is deciding whether or not to make the turn. It needs to be early enough to enable the driver to take corrective action, but not so early that it could be confusing or a nuisance. This time is initially estimated based on the sum of one second for the driver to perceive the alert and initiate a braking response, plus the time needed to decelerate from the current SV speed to a stop at the stop bar at a comfortable deceleration rate of 0.1 g. If the driver takes more than one second to perceive the alert, it would be necessary to use a higher deceleration rate to stop at the stop bar, but this initial value allows a considerable margin before that deceleration rate would become high enough to be of concern. The suitability of this alert timing will be evaluated experimentally by a representative sample of drivers as part of the current research project.

9.2.2 Calibration of Parameter Values

Several parameters of the LTAP/OD alert criteria need to be calibrated based on experimental observations of driver turning behavior and driver responses to prototype alert systems. It is also expected that these parameters will need to vary from intersection to intersection and with respect to operating conditions at individual intersections:

T_{GAPLOW} and $T_{GAPHIGH}$

These will depend on drivers' observed gap acceptance behavior, which is likely to vary with intersection geometry and operating conditions, as well as with signal phase. The time for the turning SV to make its turn will, at a minimum, depend on the intersection geometry, and may also be found to depend on traffic conditions and the signal phase.

Experiments are in progress to collect the data that will be needed to calibrate these parameters. The first set of experiments involves roadside radar and video observations of many drivers turning at several chosen intersections, to quantify their vehicle trajectories (6). These reveal important information about:

- SV turning times
- POV speed distribution
- Accepted and rejected turning gaps
- SV/POV speed change interactions
- Behavior changes based on signal phase

- Interactions with pedestrians

The second set of experiments involves in-depth observations of the turning behavior of a selected sample of drivers in three age groups when they make left turns at the same group of four intersections, repeating those turn sequences ten times each (7). These experiments are conducted in an instrumented vehicle, making it possible to collect more detailed information about their behavior, to contribute additional knowledge about:

- 1 Timing of SV driver's turning decision
- 2 Influence of driver age and gender on turning behavior
- 3 Detailed SV speed-based information

Additional experiments are being staged at PATH's instrumented intersection, with drivers driving the instrumented test vehicle, to quantify gap acceptance and rejection under carefully controlled test conditions and to assess driver responses to the prototype IDS alert system, using a dynamic roadside display. These will provide the first opportunity to evaluate how drivers change their turning behavior based on the availability of an LTAP/OD alert and to ask them what they like or dislike about the alert.

9.3 Simulations to Evaluate LTAP/OD Alerts

The LTAP/OD alert logic defined in Section 9.2 above can be evaluated efficiently using computer simulations prior to experimenting with drivers at the test intersection. These simulation experiments can help to identify timing problems and logical inconsistencies or incompleteness. They are also valuable tools for determining the influence of sensor limitations on the ability to deliver consistent and timely alerts. A wide range of sensor alternatives can be evaluated efficiently, without the need for expensive testing of all these alternatives. In particular, it is important to understand what kind of performance can be achieved with conventional inductive loop presence detection before making the case for more extensive and non-traditional sensing that may be resisted by traffic engineers. The importance of sensing vehicle speed as well as presence can be evaluated directly by implementing the LTAP/OD alert criteria with and without speed information. Similarly, the relative value of continuous sensing versus point sensing can also be assessed by comparing the alerts generated with each type of

sensing, compared to a baseline condition assuming perfect knowledge of the motions of all vehicles approaching the intersection.

9.3.1 *Models*

Models used in these simulations are intentionally simple. It is possible to understand the limitations of many countermeasure designs by making favorable assumptions about them (such as ignoring sensor noise) and showing that they still limit the information available for issuing an alert. Detailed knowledge of specific hardware is not needed. At a later stage in the research, detailed models of sensors may be used to evaluate specific designs using commercial off-the-shelf (COTS) hardware. The simplicity of the models also facilitates simulation experiments with large numbers of interactions.

9.3.2 *Sensors*

Sensors include:

1. Remote sensors: radars and other sensors that detect range/range-rate over a substantial detection region.
2. Point sensors: loops and other sensors that detect presence and possibly velocity at one location.

Each sensor has a detection region (which is simply a distance interval in the approach along which the sensor is aimed). Sensor models allow specification of the following characteristics that affect performance:

Error, in these two forms:

- Gaussian noise in the output.
- Probability of dropping the target.

Delay – processing time after detection.

Period – time interval between reports.

Sensors can be selected to detect or not to detect stopped vehicles. Sensor outputs are combined and presented to the warning algorithm using a relatively simple sensor fusion algorithm.

9.3.3 *Driver and Vehicle*

There is no need for either a reactive model of the driver or a model of vehicle dynamics. All that is needed for the preliminary evaluation work is a combined driver/vehicle model that has the following attributes:

- Length and width of the vehicle.
- Predefined trajectories that determine position, velocity, and acceleration over time along a predefined path. The times at which acceleration changes can be defined in terms of D2I, T2I, time since the start of the run, or time since the last acceleration change. (In a reactive model, acceleration would also change in response to the other vehicles.)

9.3.4 *Simulation Experiments*

An experiment involves a driving scenario and several sensor configurations. The scenario defines the movements of the vehicles, using predefined trajectories. The sensor configuration defines the characteristics and location of each member of a set of sensors. Performance of the sensor set is measured in terms of its ability to deliver timely and accurate information to the alert logic. A variety of representative and challenging scenarios have been defined to test the effectiveness of candidate alert criteria and sensor configurations, but we focus on a single example here in order to save space.

To demonstrate our evaluation methodology, we consider a scenario in which:

- The distance along the POV's path from the stop bar to the SV's turning path is 10 m.
- The distance along the SV's turning path from the stop bar to the POV's path is 10 m.
- All vehicles are assumed to be 2 m wide and 5 m long.
- A single POV approaches at constant speed (35 mph, or 15.7 m/s) and accelerates after the amber onset when it has a T2I of 3 seconds. The POV continues to accelerate through the intersection.
- A single SV approaches, decelerating at -0.7 m/s/s to reach a speed of 5 m/s at the stop bar so that it can proceed to complete its left turn at 5 m/s through the intersection.
- The initial locations were chosen so that the SV arrives at its stop bar when the POV is (kinematically) 5 seconds from its stop bar.

Figure 9.4 shows the alert status, speed, D2I, and T2I time history plots of the two vehicles. It is hard to read the closeness of the interaction from these plots, since D2I and T2I are measured to the respective stop bars on the opposite sides of the intersection. The “+” symbols in the upper left plot of Figure 9.4 show the trailing buffer time between the end of the SV's encroachment on the POV's path and the subsequent arrival of the POV. The last buffer measured in the perfect sensing case (just before the SV clears the intersection) is about two seconds. In other words, this interaction is closer than drivers should find comfortable, primarily because of the combined effects of the deceleration of the SV to make the turn and the acceleration of the POV trying to beat the red signal. The red line step change at $t = 8$ s shows when the buffer time crosses the acceptable threshold value of 3 seconds, indicating a hazardous condition, based on perfect knowledge of the motions of both vehicles. Note that this occurs well before the acceleration of the POV, so the alert would be required regardless of that late acceleration maneuver.

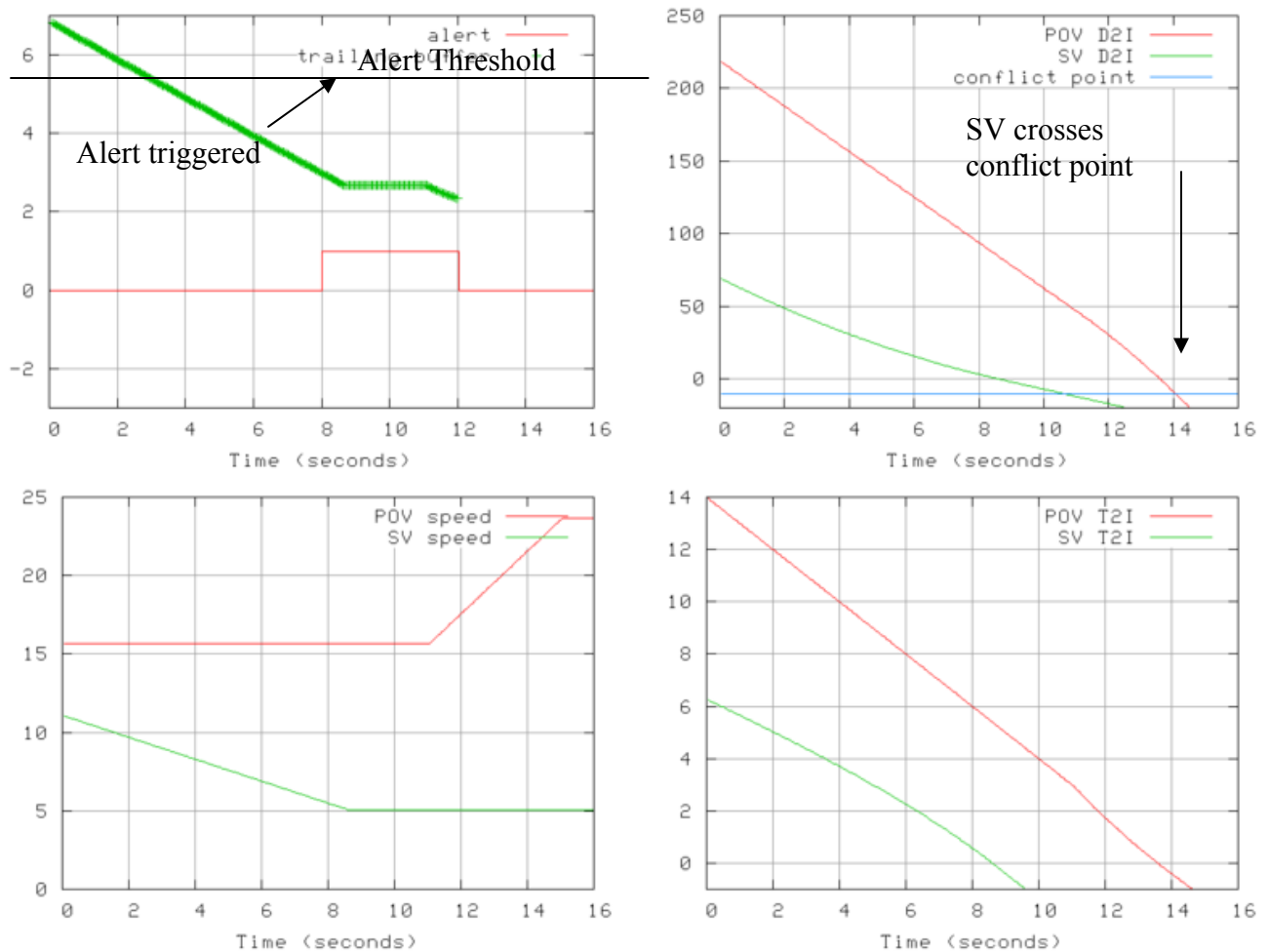

Figure 9.4 Kinematics of Encounter Between POV Accelerating to Beat Red Signal and SV Decelerating to Turn Left

The sensor configurations that have been tested in simulation against this scenario are symmetrical for the two approach directions (assuming that left turns could be initiated by SVs coming from either direction). For each of these configurations, we compare the resulting alert against that obtained with perfect sensing, which covers the entire path of each vehicle and has accurate and instantaneous information about speed and position:

1. Four loop detectors positioned at 0, 3, 6, and 9 meters from the stop bar. (We treat the three innermost loops as double loops, because speed at these loops can be estimated using detection time at the next loop out.) In this case, no alert is generated because the POV is not even detected until after the SV clears the intersection.
2. Two single loops at 50 and 100 meters from the stop bar, plus (1). The presence of the POV is detected by the additional loops, but without the speed information that would be needed to estimate its arrival time at the intersection and the available buffer time, so an alert cannot be generated.
3. Two double loops at 50 and 100 meters from the stop bar, plus (1). This case is illustrated in Figure 9.5, compared to the perfect sensor case. The POV is detected by the first pair of loops (at 100 m), at $t = 8$, leading to the generation of an alert that is only slightly delayed from the perfect sensor case, and requiring the SV to brake at about 0.2 g in order to avoid the conflict (however, it is already too late for the SV to be able to stop at its stop bar).

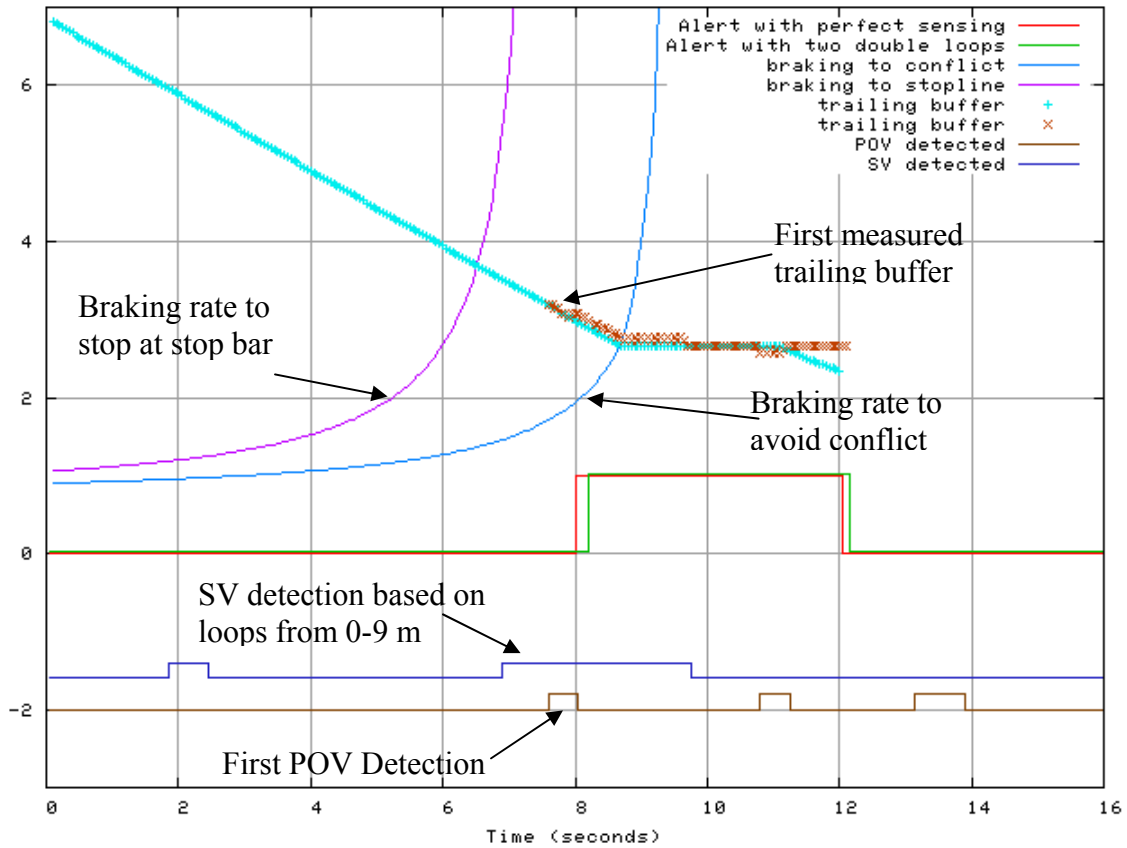

Figure 9.0.5 Sensor Detection of Vehicle Trajectories and Their Use to Trigger Successful IDS Alert

4. Three double loops at 20, 50 and 75 meters from the stop bar, plus (1). As illustrated in Figure 9.6, this case produces an alert that is delayed by somewhat more than one second compared to the perfect sensor case because of the reduced detection range, and that delay makes it much more difficult for the SV to stop comfortably (requiring about 0.6 g braking to avoid the conflict).

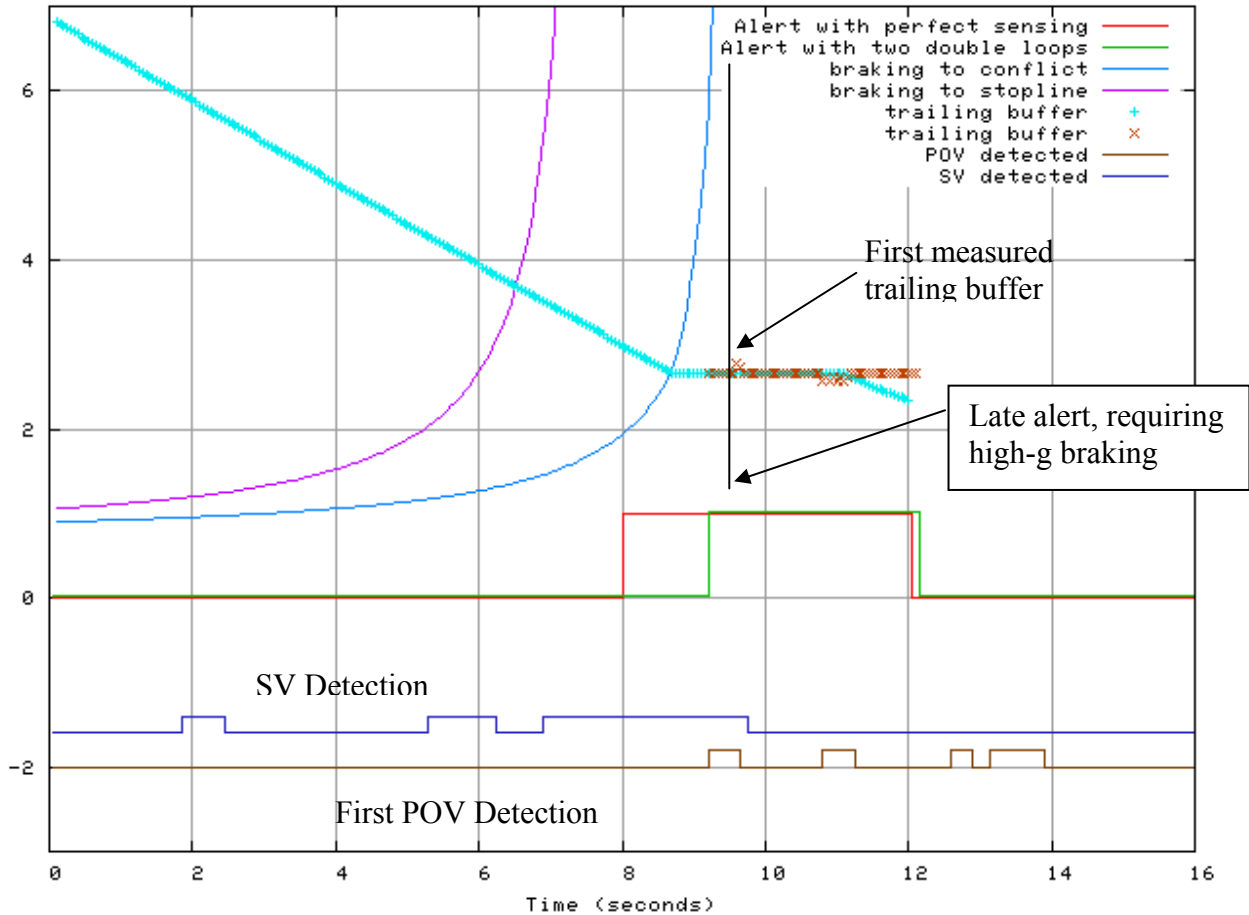

Figure 9.0.6 Sensor Detection of Vehicle Trajectories Insufficient to Trigger Timely IDS Alert

- Radar with coverage from 0 to 100 meters, plus (1). The hazardous condition is detected when the POV enters the radar’s detection region at 100 m, producing an alert comparable to that in case 3 above.

This example illustrates some important sensing requirements:

- the need to detect both presence and speed of the approaching vehicles in order to identify potential conflicts;
- the need to provide sensing of vehicle presence and speed at a substantial distance from the intersection in order to detect the POV threat early enough (6 seconds before it arrives at its stop bar, in order to support trailing buffer alert criterion of 3 seconds);

- the need to provide fairly continuous sensing of vehicle presence and speed close to the intersection in order to track the movement of the relatively slow SV during the time when its driver will need to be alerted to a potential conflict that could require delaying or aborting the turn.

9.4 Sensitivity to Insufficient Information About Vehicle Motions

It is not always easy or inexpensive to obtain complete information about the motions of the vehicles approaching an intersection, yet the IDS system needs to be as affordable as possible in order to have good chances for widespread deployment. It would be desirable to implement IDS with a minimal sensor suite in order to minimize the cost and difficulty of deployment, so it is important to understand what capabilities would have to be traded away in order to reduce costs.

It is also important to understand the range of driving conditions under which adequate alerts can be generated.

It is more difficult to generate IDS alerts when the interacting vehicles engage in more aggressive maneuvers. The scenarios that were described in Section 9.3 above included a substantial acceleration by the approaching POV, representing an attempt to beat the red signal transition. It is even more difficult to generate an appropriate alert when the SV is decelerating aggressively, as shown by the simulation results of Figure 9.7. This figure shows that even with “perfect” sensing of the location and speed of the approaching vehicles, by the time the alert threshold trailing buffer value of 3 seconds is reached, it is necessary for the SV to decelerate to a stop at 0.29 g (fairly hard braking) in order to avoid a crash with the POV. This leaves very little margin for sensing imperfections to further delay the identification of that threshold in real-time implementations.

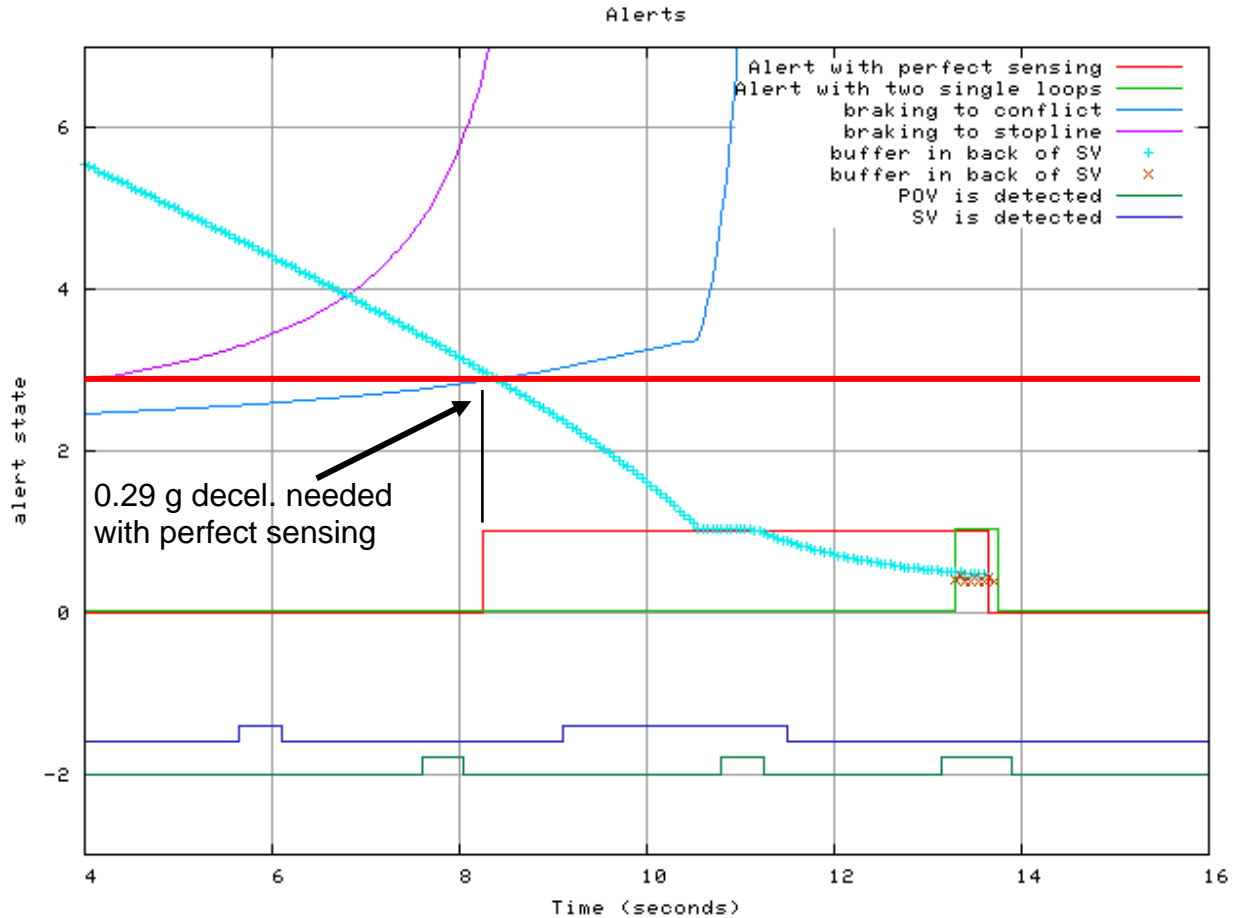

Figure 9.0.7 LTAP/OD Alert Challenges with SV Decelerating at 0.2 g

With limited detector coverage, even a relatively modest deceleration by the POV (0.07 g) can introduce a risk of false alarms when the intersection encounter is not close enough to warrant an alert. This is shown in Figure 8, for a case with double loop detectors at 100 m and 50 m from the intersection, in addition to the more typical cluster of four loops right behind the stop bar. In the lower right quadrant of this figure, it can be seen how the estimate of time to intersection for the POV becomes “stale” because it is not updated between 100 m and 50 m, during which period the POV is actually decelerating.

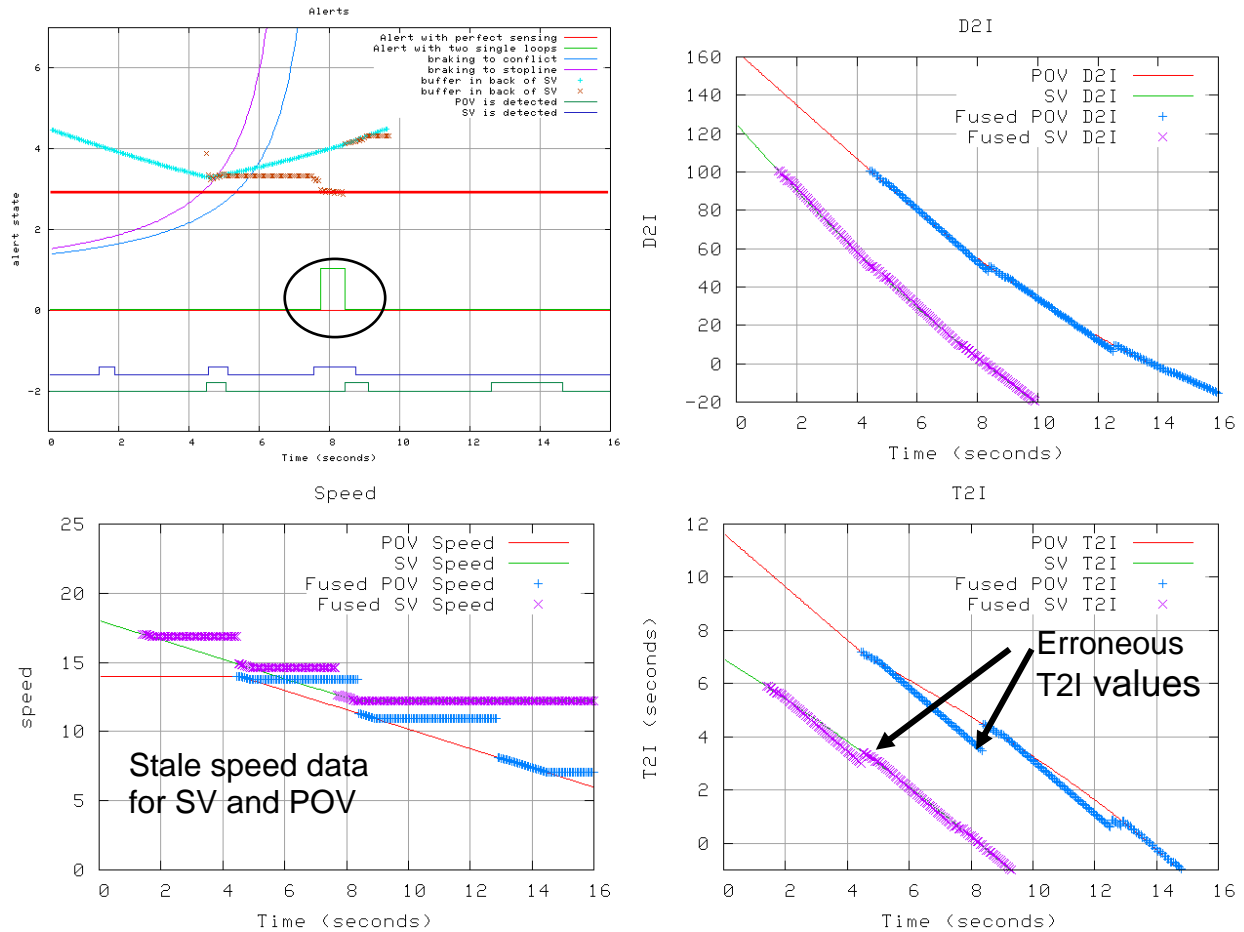

Figure 9.0.8 LTAP/OD False Alarm Challenges with POV Decelerating at 0.07 g

As a consequence, the trailing buffer estimated based on the speed of the POV measured at the 100 m distance decreases below the 3 second threshold value for a period of about one second, generating a false alarm around $t = 8$ seconds in Figure 9.8.

A variety of other cases have been studied, leading to the following conclusions about the generation of suitable LTAP/OD alerts:

- In order to understand the richness and complexity of the interactions between SV and POV, it is necessary to simulate many cases with differences in the vehicle arrival times at the intersections. The most important cases to evaluate are the borderline cases in which the alert threshold is barely crossed or barely missed because these best demonstrate the sensitivity of the alert system to imperfections.

- In the challenging cases, the final four inductive loops at the intersection have been shown to be valuable for providing vehicle presence and speed information, especially for the slow-moving SV during the seconds immediately preceding its turning maneuver. These loops should be used in consecutive pairs as double loops in order to obtain vehicle speed information.
- Vehicle speed information accuracy appears to be at least as important as vehicle location information accuracy.
- SV speed changes close to the intersection are more difficult to deal with than POV speed changes, so particular attention needs to be devoted to ensuring that accurate SV speed information is available with frequent updates.
- Aggressive decelerations by an SV approaching a left turn are difficult to address, because they leave little time available for updating estimates of LTAP/OD threat severity. In contrast, hard decelerations of POVs to stop or accelerations of POVs to beat signal phase changes are not as difficult. The accelerations of the POVs occur too late to create hazardous encounters, while the decelerations can be detected early enough to be accommodated within the threat assessments. These findings indicate that higher priority should be given to detecting SV motions than POV motions close to the intersection.
- If detector coverage on the intersection approach is too sparse, gradual decelerations of POVs can lead to false alarms.

Particular attention has been devoted to the special case of no velocity information about the approaching vehicles, but only presence detection. This has been suggested as a potential low-cost IDS strategy, based only on use of single-loop presence detectors, and then assuming vehicle speeds based on local aggregate traffic data statistics (such as the 85thile speed). This concept has been studied in simulation to determine how vulnerable it could be to false positives or negatives. The example has been based on the Shattuck/Hearst intersection in Berkeley, for which we have collected substantial data. At that intersection, the approach speeds are in the range of 20 mph to 30 mph (posted speed limit is 25), and we assumed an 85thile value of 28 mph for purposes of generating the IDS alert. In the absence of detailed data on loop detector latency, accuracy and reliability, we assumed perfect performance in all these dimensions, for

single loops located at 100 m and 50 m from the stop bar, together with the final four loops clustered at the stop bar.

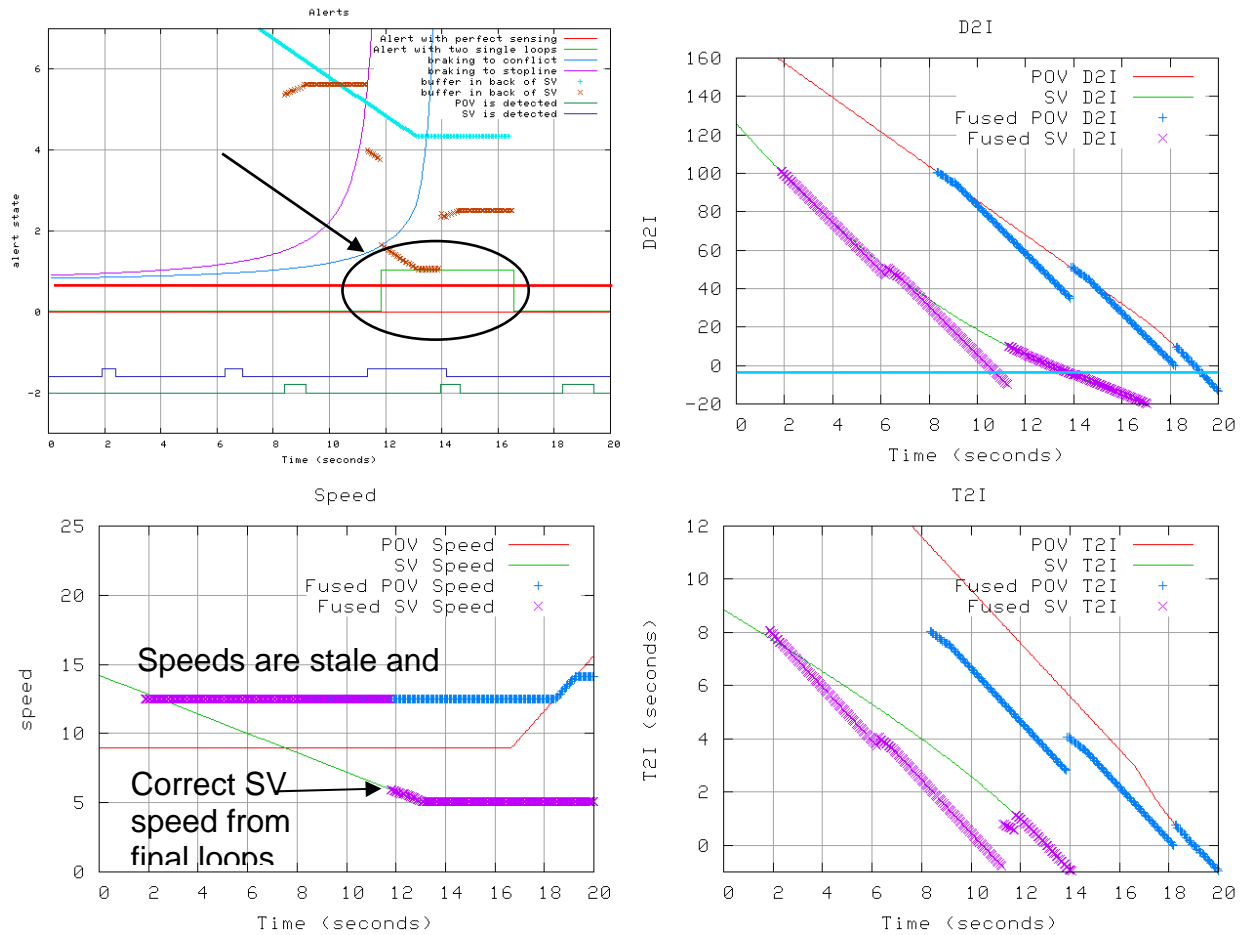

Figure 9.0.9 Example of False Positive for POV Approaching at 20 mph, but Assumed at 28 mph Default Speed

For the first simulation case, we studied a POV approaching at 20 mph in a situation that did not produce a close enough encounter to merit an alert to the SV. However, when the default speed of 28 mph was incorporated in the alert criterion, it led to an extended false alarm (about 5 seconds), as shown in Figure 9.9. The estimates of T2I were seriously distorted by this speed error, and even though the use of the final loops in pairs made it possible to give an accurate update of the SV speed, the POV speed estimate was seriously wrong. Note that the actual trailing buffer value was above 4 seconds for this entire period, but the erroneous speed estimate led to assumed trailing buffers between 1 and 2.5 seconds, all well below the alert threshold of 3 seconds.

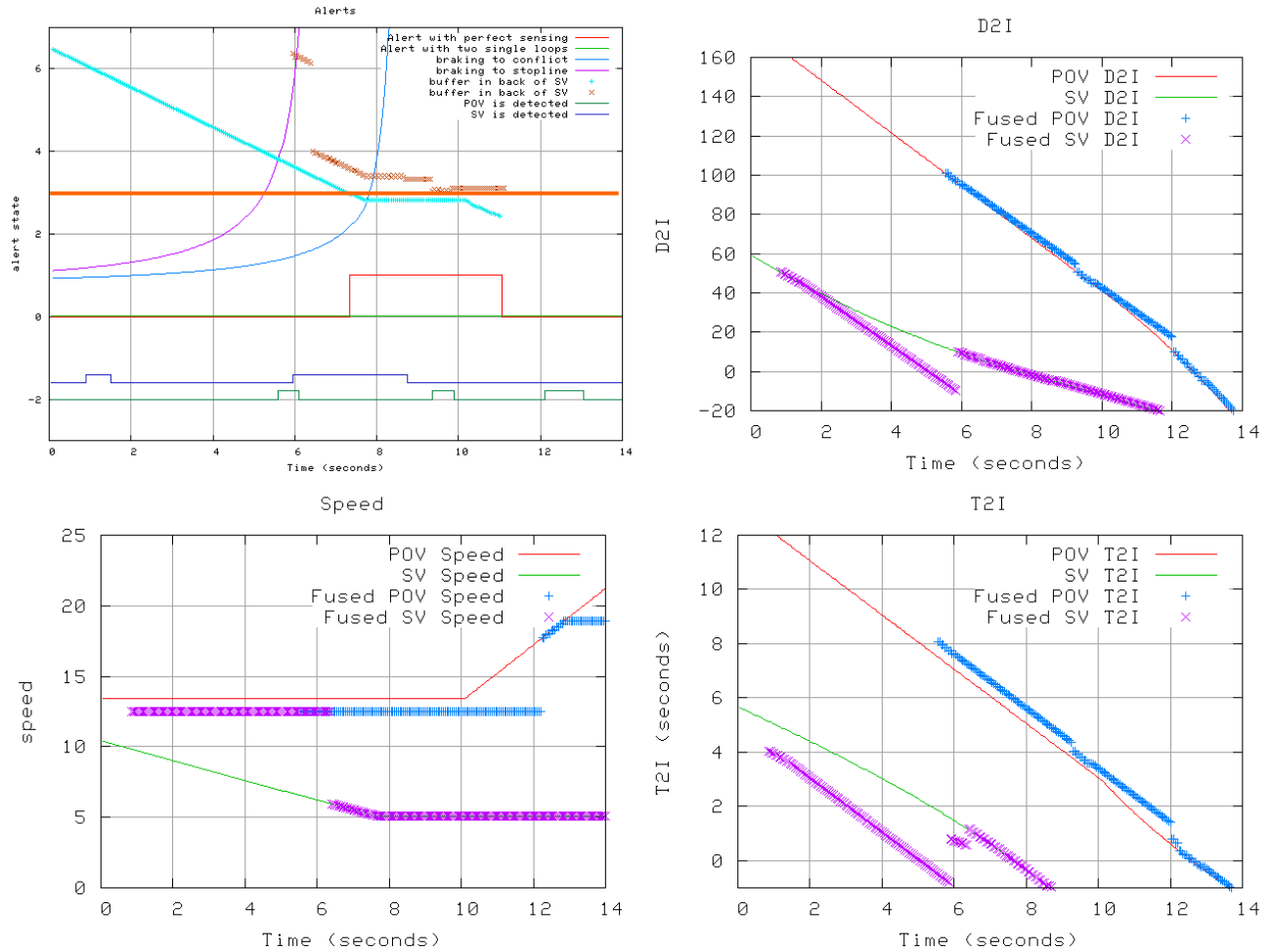

Figure 9.0.10 Example of False Negative for POV Approaching at 30 mph, but Assumed at 28 mph Default Speed

In the opposite case, with the POV approaching at 30 mph but assumed to be at 28 mph, we encountered the opposite problem of a false negative (missed detection), as shown in Figure 10. Here, the actual trailing buffer was below the 3 second alert threshold for an extended period (almost 4 seconds), but the erroneously low assumed speed led to an assumption of a higher buffer value throughout that time, preventing the alert from being generated. Even the small speed discrepancy of 2 mph produced this extended false negative because the actual buffer value was so close to the alert threshold.

The preceding two sets of results were generated assuming that the most appropriate speed to assume for generating the alert was around the 85%ile. In order to check the sensitivity of the results to this assumption, another case was tested for an assumed mean speed value of 25 mph. The results of this case for an actual POV approach speed of 30 mph are shown in Figure 9.11. It can be seen that the alert threshold value was crossed so late that the alert was delayed by more than 3 seconds, requiring the SV driver to brake at a very high rate (above 0.6 g, off the scale of the plot) in order to avoid the conflict with the POV.

Since this is a very undesirable circumstance, it shows the inadvisability of choosing the mean speed value, and weighs more in favor of the originally proposed 85%ile default speed estimate. Basic conclusions from this study of generating LTAP/OD alerts without real-time measurements of approaching vehicle speeds are:

- If the assumed speed is below the actual speed of the approaching vehicles, the alerts will be issued late or will be missed entirely. Since these are unsafe outcomes, the assumed speed will have to be in the upper range of the actual speeds encountered.
- The larger the difference between the actual and assumed speeds, the more severe the consequences will be. The most likely causes of LTAP/OD crashes are driver underestimates of the speed of fast approaching vehicles, so an alert system that mimics driver errors would not be very effective in reducing these crashes, which also have the most severe consequences for the vehicle occupants.
- If the assumed speed is above the actual speed of the approaching vehicles, false positives (false alarms) become more likely.
- The likelihood of occurrence of these problems depends on the variability in the speed distribution of the approaching vehicles. If the approaching vehicle speeds are clustered close together, the problems are much less important than if there is a wide variation in approaching vehicle speeds.

9.5 Conclusions

The encounters between left-turning vehicles and oncoming vehicles at intersections where left turns are permitted but not protected are complicated for drivers to manage safely, and the safety of these encounters could be improved by use of intersection decision support (IDS) systems that can provide accurate and reliable alerts about insufficient gaps for completion of the left turns. The human factors and engineering issues that must be incorporated into the design of such an IDS system have been identified and described here. Based on those considerations, a logical framework has been defined to determine the conditions in which a gap should be judged unacceptable and to define the most suitable time to alert drivers to delay their left turns. Initial parameter values have been chosen to use in the alert logic, based on preliminary observations of intersection turning behavior, and these values will be refined on the basis of more extensive ongoing data collection activities.

A simulation tool has been developed to test the general validity of the alert logic, and its use has been illustrated by example. The simulation can be used to test a wide variety of intersection encounters, using hypothetical vehicle maneuver profiles intended to represent complicated conditions, as well as using real data describing vehicle trajectories observed in the field. The simulation is also useful for comparing IDS alert generation for a range of sensor configurations against a base case assuming that perfect information is available. This can provide useful guidance for initial selection of sensor types, locations, and coverage zones. Once those are defined, real sensor limitations in accuracy, noise and sampling and filtering delays can also be incorporated to determine how significantly these may limit the ability of the IDS to issue accurate and timely alerts to drivers.

9.6 REFERENCES

1. Wang, J.-S., R. Knipling, “*Intersection Crossing Path Crashes: Problem Size Assessment and Statistical Description*,” National Highway Traffic Safety Administration: Washington, D.C., DOT-HS-808-190, 1994.
2. Ferlis, R.A., “Analysis of an Infrastructure Collision Avoidance Concept for Straight Crossing Path Crashes at Signalized Intersections,” Annual Meeting of the Transportation Research Board: Washington, D.C., January 2001.

3. Misener, J.A., Ragland, D., Wang X.Q., Cohn, T.E., "Toward a Smarter, Safer Intersection: Application of Intelligent Countermeasures to the Intersection Crash Problem," *ITS World Congress*, Madrid, Spain, November 2003.
4. Smith, D.L., and Najm, W.G., "Analysis of Crossing Path Crashes for Intelligent Vehicle Applications", *Eighth World Congress on Intelligent Transport Systems*, Sydney, Australia, October 2001, Paper No. ITS00533.
5. Shladover S., Ragland D., Chan C-Y. and Marco D., "Measuring Intersection Turning Behavior to Support Design of an Intersection Collision Warning System" , *ITS World Congress*, Nagoya, Japan, October 2004.
6. Chan, C.-Y, Ragland, D., Shladover, S., Misener, J. and Marco, D., "Observations of Driver Time-Gap Acceptance at Intersections in Left-Turn Across-Path Opposite-Direction Scenarios, 2005 TRB Annual Meeting, Paper No. 05-2159.
7. Cody, D., "Analysis of Exploratory Field Test Data from an Instrumented Vehicle: Description of Left Turn Maneuvers for Intersection Safety Countermeasure Design", 2005 TRB Annual Meeting, Paper No. 05-2255

10 TOOL 1: SENSOR AND WARNING SYSTEM EVALUATION IN SPECIFIC INTERSECTION GEOMETRIES WITHOUT DRIVER MODEL

10.1 Overview

The scope of this tool is evaluating sensors and warning systems in settings that are restricted in the following ways:

- The set of intersection geometries is narrowly restricted.
- Vehicle movement is defined in terms of [explicit trajectory](#) rather than as the output of driver/vehicle models.
- There is only one SV and one POV.

These restrictions are explained under model requirements. The advantages of these restrictions are fewer variables, more control over an entire simulation run, and faster execution.

The goal of this tool is preliminary evaluation of [countermeasures](#). The evaluations are preliminary in the sense that their results may indicate that large classes of countermeasures are not feasible for IDS. The remaining countermeasures would be candidates for study in real-world experiments and in simulations with more varied geometries and more detailed models (tool 2 and tool 3).

The intended applications of this simulation tool include:

- Evaluation of a particular sensor set with specified layout and detection parameters.
- Comparison of several warning criteria.
- Generation of sensor requirements.
- Error sensitivity analysis.

Note: this document is based on a set of HTML documents. The HTML documents were written as on-line documentation for the IDS software. They make heavy use of hyperlinks (including a hyperlinked glossary) and are used as link targets from the software itself. The hyperlinks have not all been retained in this report. The original set of documents can be browsed at the IDS site: <http://path.berkeley.edu/IDS>.

Some results using this tool have been published as [TRB2005 Paper, final draft](http://path.berkeley.edu/IDS/Papers/TRB05_IDS_Final.doc) (http://path.berkeley.edu/IDS/Papers/TRB05_IDS_Final.doc).

10.2 Software Requirements

Overview

This document describes the requirements that these goals impose on the functionality of the software for input, output, and control of simulations.

Inputs

Management of [experiments](#)

- Selection of the [scenarios](#) and [countermeasures](#) in an experiment
 - For each scenario:
 - Selection of the number, dimensions, and trajectories of the vehicles involved
 - Trajectories are specified [explicitly](#).
 - For each countermeasure:
 - Selection of the sensor locations and characteristics
 - Selection of warning criteria
 - From fixed list of choices: PATH, BMI, etc.
 - Additionally, parameters can be specified
 - Multiple warning criteria are accepted
- Selection of the global parameters of the experiment, such as simulation time-step

Outputs

Plots

- Time-history plots of vehicle measurements (speed, [T2I](#), etc) and of sensor and warning outputs
- Phase plane plots of pairs of measurements
- Statistical plots of false-positive and false-negative durations

Control

- Starting and stopping the sequence of simulation runs (one for each scenario/countermeasure pair) involved in an experiment
- Executing a particular run, independent of the others
- Desirable: preview run for a scenario (with no countermeasure specified)

10.3 Model Software Architecture

Overview

This document describes the implementation of sensor, driver, vehicle, and roadway models as RedShift components. We also discuss the interface to algorithms for sensor fusion and warning time selection. The details of those algorithms are discussed elsewhere, since they are not part of Task S1.

Components

In this document we discuss the [components](#) that implement the [models](#). We focus on the static and dynamic semantics of these components, including their internal state changes, their clocks, and their interactions with other components by discrete [event](#) propagation, continuous data flow, and shared data structures.

Sensors and their interfaces to the warning system

Sensor models are infinitely variable (depending on error models, on detection region, ability to detect speed, etc.) but are all implemented in terms of one class of components, called “sensor”. Sensor characteristics are covered in the [model report](#). The interfaces by which sensor data is transmitted to the warning system are discussed below.

Sensor interface to sensor fusion

The sensor components each provide one or more [queues](#) of output data:

- *d2i_report* ([D2I](#))
- *speed_report*
- *t2i_report* ([T2I](#))

Each data point in each of these queues is a *(time, value)* pair. Sensors do not export any [events](#).

The sensor's output queues are shared by sensor fusion. The sensor fusion component periodically consumes data points from these queues. The period of the sensor fusion need not be the same as the period of the sensors (which may differ among themselves). One effect of the queue is to insulate the sensor fusion component from these clock differences.

The sensor fusion is responsible for interpreting the *time* field of every data point: if the time is still in the future, the data should not be used yet. The purpose of having a sensor that outputs data in the future is that it simplifies implementation of delay: the sensor does not have to hold the data for the duration of the delay and then release it. It simply releases a future data point as soon as the *time* and *value* have been determined. We do assume that, for a particular queue, data points are released to the queue in temporal order.

In addition, the sensor fusion component may observe static properties of each sensor such as delay or error distribution. These properties can be used to make an estimated correction for delay and in Kalman filtering, respectively. The sensor fusion component keeps a list of references to the sensors from which it is receiving input and can use these references to observe the sensor's static characteristics.

Sensor fusion interface to warning criterion

In the restricted scope of Tool 1, sensor fusion can assume that there is only one vehicle. This assumption simplifies the interface. Outputs are divided into two parts. The first part of the outputs consists of three queues of data, just like the sensors:

- *d2i_report*
- *speed_report*
- *t2i_report*

Each data point in each of these queues is a *(time, value)* pair. A data point is present if and only if at least one corresponding sensor output is available—no extrapolated data is inserted.

The second part of the outputs consists of the current best estimate of each of the three variables, using extrapolation if necessary:

- *d2i*
- *speed*
- *t2i*

The necessity of extrapolation may be decided by the sensor fusion algorithm. For example, if no data has arrived for a variable in N seconds (a small number, such as 0.1), sensor fusion might use extrapolated data instead. If too much time has elapsed to use extrapolation, the value in the best estimate output should be *nil*.

Sensor fusion does not export any [events](#). The sensor fusion component is polled for an update to its outputs on every time step, so it may accommodate sensors with arbitrary update rates.

Warning manager component and interfaces to warning algorithms

The warning manager component supports multiple warning algorithms, for comparison purposes. The component reads outputs every time step from the SV sensor fusion and from the POV sensor fusion, makes the outputs available to each warning algorithm, and

records their outputs for use in performance measurement. The warning algorithms themselves are not components—they do not need to be because the warning manager handles the necessary time-response behavior for them. However, the warning algorithms are not required to be purely functional—they may retain state over time.

The interface between the manager and each warning algorithm is as follows: The warning algorithm may query the manager for current POV and SV fusion outputs (both the fused data queue, including historical data, and the current best estimate for each variable), signal state, and any other data the manager is aware of.

The algorithm must output one of two types of messages:

- ON: Turn warning on.
- OFF: Turn warning off.

Each of these messages may be accompanied by a time parameter, t , which indicates that the action selected by the message is to be sustained for t seconds. For example, the message $(ON, 2)$ indicates that the warning should be immediately illuminated and held for 2 seconds, regardless of the inputs to the algorithm over that time period. If no time parameter is given in the output message, the algorithm will continue to receive inputs at every time step.

10.4 Model Requirements

Overview

This document describes the requirements that these goals impose on model characteristics and fidelity and the assumptions that we may make given these requirements.

Related documents

The details of the parameters, formulas, logic, calibration, etc. of the models are presented in the [model report](#). The implementation of models in RedShift is discussed in the [model software architecture document](#).

Algorithms for sensor fusion and warning timing are not modeled. Instead we use their actual implementation, simplified where possible, which is shared with other parts of the IDS project. Primary documentation for these entities is elsewhere. The interface to them is discussed in the [model software architecture document](#).

10.5 Sensors

Sensors include:

- Remote sensors: radars and other sensors that detect range/range-rate.
- Point sensors: loops and other sensors that detect presence and possibly velocity.

Each sensor has a detection region (which is simply a distance interval in the approach along which the sensor is aimed). Detection regions of different sensors in the same countermeasure may overlap. Beam width of remote sensors is not relevant at this stage, since trajectories are one dimensional and therefore the beam region reduces to detection interval along the vehicle path.

Sensor models allow specification of the following characteristics that affect performance:

- Error, in at least two forms:
 - Gaussian noise in the output.
 - Probability of dropping the target.
- Delay – processing time after detection.
- Period – time interval between reports.

Sensors can be selected to detect or not to detect stopped vehicles.

Sensors detect just a single vehicle at a time, since there is at most one vehicle per approach.

10.6 Driver and Vehicle

There is no need for either a reactive model of the driver or a model of vehicle dynamics. For the purposes of this tool, all that is needed is a combined driver/vehicle model that has the following attributes:

- Length and width of the vehicle.
- [Predefined trajectory](#).
- Measurable position, velocity, and acceleration along a predefined path over time.
- For the turning ([SV](#)) driver, measurable value of the suitability (and earliness or lateness, if not suitable) of the warning. (This value is not fed back into the simulation.)

We require only a single POV and a single SV because otherwise a more sophisticated sensor fusion will be needed, and that depends on further work in other parts of the IDS project.

10.7 Road Geometry

Road geometry models make available the following information, with very high precision (<0.1m):

- Distance and relative speed between turning and approaching vehicles.
- Distance from approaching vehicles to stop line.

For the preliminary evaluations, we do not need angular measurements or lateral displacement. In fact, we can assume that the intersection is orthogonal, and has one lane in each approach direction and no median, no turn lanes, etc. The only geometric characteristics of the intersection that must be open to specification are length and width. There is no limit on the starting distances of vehicles.

10.8 Model Report

Overview

This document describes the details of the models chosen to fulfill the requirements given in the [model requirements](#) document.

Models used in these simulations are intentionally simple. It is possible to reject many countermeasure designs by making charitable assumptions about them (such as ignoring sensor noise) and showing that they still are not feasible for IDS. At a later stage in the research, detailed models of sensors may be used to evaluate specific designs using COTS hardware. The simplicity of the models also facilitates simulation experiments with large numbers of runs. Preliminary evaluation in this simple setting can be used to narrow down the wide range of possible countermeasures to a small set to be considered later in more detail.

10.9 Coordinate Systems

This tool's simple requirements permit the use of very simple coordinate systems. There is a separate coordinate system for each direction of approach to the intersection. Each coordinate system consists of a single dimension, with vehicles approaching from the negative direction, with a positive velocity. The stop line at which the vehicle enters the intersection is at 0. Converting between these systems is trivial (using the dimensions of the intersection box), and calculations are simple and fast. A [component](#) (such as a sensor or vehicle) which is specified in terms of locations (e.g., boundaries of its detection region) is defined in terms of one such coordinate system.

Sensors

Radars

- EVT-300
 - Range
 - maximum 110m
 - error 5%
 - Range rate
 - error 5%
 - Does not detect stopped vehicles

Other sensors, such as loops, are assumed to be “perfect”, though perhaps are limited by coverage, delay, update rate, and ability to detect speed.

10.10 Software Manual

Overview

This manual focuses on the Graphical User Interface of the EvalTool. The tool also has a batch interface, for which documentation is available using the `-h` switch.

Documents

The documents operated on by *EvalTool* are [experiments](#). An experiment is displayed as a table in which each row corresponds to a [scenario](#) and each column corresponds to a [countermeasure](#). The user defines some scenarios and countermeasures using the menus or the buttons along the left and top margins of the table. If a cell is in a row and a column for which a scenario and a countermeasure have been defined, the cell represents a complete [world](#)—the behaviors of the vehicles and the reactions of the safety system are determined according to the models discussed in the [model report](#). Characteristics of a cell (i.e., a world) can be viewed but not edited individually except by editing characteristics of the corresponding scenario and countermeasure, which apply to a whole

row or column in the table, or by editing the global settings of the experiment, which apply to all worlds.

Starting the Program

Starting the program is simple: just double-click on the file named “eval-tool1.rb” in the folder that you unpacked from the zip file.

Getting Results

Each cell that represents a fully defined world may be inspected in several ways, such as by plotting the time-history of the vehicle positions in the world or by plotting the sensor readings along with the true positions and speeds of a vehicle. The aggregate behavior of a number of cells can be plotted, and 3D plots over the cell grid itself are possible.

Getting Help

Most Dialog windows have a *Help* button that opens the relevant page in the hypertext documentation. The main window has a *Help* menu for browsing on-line and web-based documentation. The hypertext documents focus on how the GUI widgets relate to modeling objects and on the process of designing an experiment,

Quick help on the operation of the GUI is available from the *Help/Tips...* menu command. The tips focus on the operation of the GUI, without regard to the underlying models and experiments; the content of the tips is complementary to the content of the hypertext documents. **It's helpful to skim these tips before starting and to refer to them while using the program.** The tip window can be left open while working in other windows of the *EvalTool* GUI.

Most GUI elements (menu commands, buttons, fields) have brief tips that appear both in floating windows and in the status line at the bottom of the current window when the mouse pointer hovers over the GUI element.

Papers with a deeper investigation of the models, algorithms, and experiments, can be found at <http://path.berkeley.edu/IDS/Papers>.

Contents

The major components of *EvalTool* are discussed in the following sections:

- [Main Window](#)
- [Experiment Table](#)
- [Experiment Dialog](#)
- [Countermeasure Dialog](#)
- [Scenario Dialog](#)
- [Preferences Dialog](#)
- [World Dialog](#)

Appendices:

[Plotting](#)

Main Window

The main window of the *EvalTool* GUI displays the currently loaded experiment and provides some menu commands for manipulating it and for other tasks. The experiment is displayed in a table with rows and columns representing scenarios and countermeasures. The table is documented in the [Experiment Table](#) section. Most menu commands have standard behavior. Those which do not are documented below.

File / Import and *File / Export* – Read or write the experiment design to or from a human-editable text file. This is useful for several purposes, such as exchanging experiments between users on different computers and manually editing experiment parameters. The file suffix used for these files is “.yaml”, indicating the use of the YAML language for serializing data structures in human-readable text.

Experiment / Update – When selected (as indicated by check mark in menu), worlds are updated as soon as their inputs change. Otherwise, worlds are only updated when necessary (for instance, when the user requests a [World Dialog](#)). Choosing between the two settings is a trade-off between using CPU time eagerly, early, and possibly

unnecessarily and using CPU time lazily, late, and possibly with delay to the availability of results.

Experiment / Cancel Updates – Stop all updates that have been scheduled due to changes in inputs (if the *Experiment / Update* mode is selected) or due to explicit user requests.

Countermeasure / Mark as Baseline – Mark the selected countermeasure as the baseline case against which other countermeasures will be compared. Typically, this case will use perfect sensing.

Experiment Table

The *Experiment Table* displays and edits the current state of the experiment, including global settings, [scenario](#) and [countermeasure](#) designs, and the execution state of each [world](#).

The table is navigable with mouse and cursor keys. Pressing return or double-clicking on a cell opens the world associated with that cell.

The execution state of a world is one of:

Blank – nothing is known about this world.

Red World  – EvalTool is updating this world.

Blue World  – EvalTool is finished and the world is up to date.

Experiment Settings Dialog

The experiment settings dialog is used to define characteristics of the current [experiment](#) as a whole. This includes:

- Run time and time step for each [world](#). Run time is the number of seconds for which to run the world. Time step is the smallest indivisible unit of time in the simulation.
- Intersection characteristics:
 - Distance from the POV's stop line to the SV's turning path.
 - Distance from the SV's stop line to the POV's straight path, measured along the curve of the SV's path.

- Maximum time through the intersection. Used as an upper limit in T2I calculations.
- Design speed. Used in calculating scenario parameters: higher design speeds require the simulation to start with the vehicles further apart to capture all relevant phases of the interaction. Does not affect the motions of vehicles—only forces the simulation time window to start earlier.
- Tracing settings:
 - Tracing can be turned on or off as a whole.
 - Individual parts of trace data can be turned on or off., trading off between disk space usage and information retention for post-execution analysis. (These settings do not affect the scenario preview feature, which uses its own logic to determine what needs to be saved.)

These settings are in effect across the entire experiment.

Countermeasure Dialog

The countermeasure dialog is used to specify the following attributes of a [countermeasure](#):

- Choice of alert criteria.
- Parameters for the alert criteria.
- The sensor set for the POV approach.
- The sensor set for the SV approach.

These specifications apply just to a single column in the experiment table; a column represents a set of worlds sharing the same countermeasure specification. Different columns may have different specifications.

The dialog has several features to accelerate countermeasure design:

- The *Copy sensor list up* and *Copy sensor list down* buttons, which copy the SV (or POV) sensor set and overwrite the POV (or SV) sensor list with the copy.

- Templates for sensor lists. The templates have been selected to provide commonly used sets of sensors.
- Scale factor for templates, so that a single template can be applied in a variety of situations, such as intersections with varying levels of expected speeds.
- Base sensor types, to provide a base of standard parameters for a single sensor, which can be edited.

Note that the experiment table permits copy and paste operations on columns (and rows), which can also save time in designing a sequence of countermeasures.

Alert Criteria

The alert criteria are selected by clicking in the box in the section labeled Alert Criteria. In addition, each set of criteria may have parameters. The values of these parameters are set by clicking on the *Configure Parameters* button and entering values in the dialog box that appears. Details of the available alert criteria are discussed in the papers on warning design.

POV Sensors and SV Sensors

The two sections labeled *POV Sensors* and *SV Sensors* each operate in the same way: they each edit a list of sensors on one approach to the intersection. These two sections are generically termed “sensor list editors”. A sensor list editor has several groups of controls:

Controls for creating, deleting, and re-ordering sensors

The controls on the left-hand pane of the sensor list editor apply to the displayed list of sensors.

- *New* – add a sensor to the list. The sensor's characteristics can be defined with the individual sensor controls on the right.
- *Delete* – delete the selected sensor from the list.
- *Move up* – move the selected sensor up in the list. This does not affect simulation.

- *Move down* – move the selected sensor down in the list. This does not affect simulation.
- *Apply template...* – selecting a sensor template in the box causes that list of sensors to replace the current sensor list. The list can be edited further.
- *Scale factor* – selecting a scale factor before selecting a template scales the placement (but no other characteristics) of all of the sensors except the standard loop set.
- *Include standard loops* – selecting this box will include the standard loop set—four loops near the stop line.

The sensor list box

The sensor list box occupies the middle pane of the sensor list editor and is used to select a single sensor. A selected sensor can be deleted or moved up or down using the controls on the left. The selected sensor's characteristics are displayed and editable in the controls in the pane to the right of the list.

Sensor characteristic fields

The controls on the right-hand pane of the sensor list box display the characteristics of the selected sensor:

- *Name* – the sensor name, for reference.
- *Base type* – the general type of sensor, which influences the other characteristics.
- *Coverage* – two endpoints that define the region in which targets may be detected. Endpoints are expressed in meters to the stop line (i.e., D2I).
- *Period* – time, in seconds, between reports from the sensor to the sensor fusion module.
- *Delay* – time, in seconds, between occurrence of the observed event and completion of any internal processing within the sensor that must take place before data is sent to sensor fusion.

Note that not all characteristics of sensors are currently shown in the editor. There are differences between radars and loops, for instance, that are not represented individually

the edit fields, but are determined by the choice of base type. See the [model report](#) for details.

Scenario Dialog

The scenario dialog is used to specify a [scenario](#), which, in EvalTool1, consists of the trajectories of the approaching vehicles.

Note that the [experiment table](#) permits copy and paste operations on rows (as well as columns), which can save time in designing a sequence of scenarios.

The *Name* field sets the name of the scenario, which may be any text that fits on one line. The name is displayed in the experiment table in the row header that corresponds to the scenario.

The *Type* box selects the type of scenario from several alternatives. On selecting a type, the contents of the box below the type box change to reflect the parameters of the type. The parameters for each type are documented within the window itself.

The *Preview* box contains buttons to display the time-history plots generated by the current scenario settings. The *Select Data* button displays a menu of plot elements: vehicles and variables. The *Plot* button generates, for each variable selected, a plot window, which includes a curve drawn using data from each vehicle selected. The windows may be closed manually, by pressing the *Close Plot Windows* button, or by closing the dialog box. Any reasonable number of plot windows may be left open at the same time. See the [plotting](#) documentation.

Preferences Dialog

The preferences dialog controls settings for the *EvalTool* application in general, rather than for one specific experiment:

Application settings:

- *Detailed error reports* — when a bug is detected, display detailed information that can be sent to the developers.
- *Tooltip Delay* and *Duration* – control the appearance of the small yellow boxes that hover above GUI widgets.
- *Temporary files directory* — select the directory to use for files created while running ad-hoc simulations, constructing plots, and so on. The application will clean those files up before it quits. You may select the directory by pressing the button or by typing the name in the box. The *Restore default* button restores the setting to the default directory originally guessed by *EvalTool* based on your system settings. (Currently, this directory is only used for the Preview operations in the [Scenario Dialog](#).)

Main Window settings:

- *Remember position of window on screen* — instructs application to save the position and size of the main window when the application is exited and restore the saved values when it is started again.

Note that many other aspects of the GUI state, such as current directory, are automatically saved and restored. Normally there is no need to edit these preferences directly, since they change in response to normal operation of the GUI. However, since preferences are stored in an editable text file, they may be edited directly. To find this text file, use the *Help/Tips* menu in the main window, and select the *Advanced* tab.

World Dialog

The *World Dialog* is used to inspect the outputs from a particular [world](#). It cannot modify any characteristics of the world; these characteristics are defined by the experiment settings for the experiment as a whole and by the [scenario](#) and the [countermeasure](#) associated with the world. The dialog does however contain buttons to open the respective dialogs for these three kinds of input. After the user edits inputs in these dialogs and presses *Apply* or *Accept*, *EvalTool* will automatically refresh the information displayed by the *World Dialog*.

The dialog displays two kinds of outputs. First, there is a text box showing messages generated during the simulation. Some of these messages indicate a design problem that the user may want to address before continuing (for example, not all of the vehicles pass the stop line) or a problem with the simulation software itself (which should be copied and pasted into an email to <mailto:vjoel@path.berkeley.edu>). Some of the messages are generated by the alert system, such as estimated braking requirements when the alert is issued. The text can be copied for use in documents.

The second kind of output is plots. The variables are first selected using the controls; the *Plot* button displays the plots. See the [plotting](#) documentation.

The *Refresh* button is normally not used. *EvalTool* is responsible for making sure that the user sees the current results in output windows. However, it is provided in case you have manually changed inputs in the files on disk, and want to refresh the display to reflect those changes.

Plotting

Instructions for using the plot windows are located in the Tip window, accessible from the *Help/Tips...* menu command in the main window. Of particular interest in the preview windows are the following:

- Use two right-clicks to define a zoom region.
- Key Escape: cancel zoom region.
- Key q: close window. (Not available on windows (“Windows”? as in Microsoft?))
- Key b: toggle border.
- Key g: toggle grid.
- Key l: toggle logscale on y axis.
- Key L: toggle logscale of axis nearest cursor.
- Key r: toggle ruler.
- Key n: go to next zoom in the zoom stack.
- Key p: go to previous zoom in the zoom stack.
- Key u: unzoom.

On Windows, note that the plot window has a menu (the normal window menu with resize and minimize options), and this menu has an *options* submenu with commands to copy, print, etc. the plot window. Also, the Gnuplot shell window is available for executing plot commands.

Preparatory Analysis for the Cooperative Intersection Collision Avoidance Systems
(CICAS) Initiative

11 TASK 1 REPORT: COLLECTION AND
DOCUMENTATION OF FUNCTIONAL
REQUIREMENTS AND PERFORMANCE
SPECIFICATIONS



This report prepared for Caltrans and US DOT (ITS JPO) by:

Steven Shladover, David Ragland, Jim Misener

University of California, Berkeley PATH Program

IDS

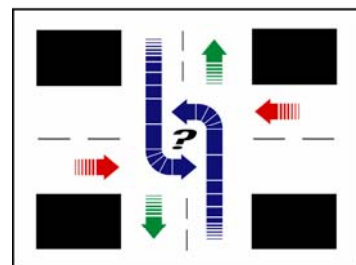

**Intersection
Decision Support**

11.1 Background and Definition of CICAS Goals

Considerable progress has been made in research, development, field operational testing and even deployment of commercial products for vehicle-based collision warnings for use in the highway environment. Intersections represent a considerably more complicated environment than highways, both geometrically and operationally, so progress has been much slower in addressing intersection collisions. There is an important opportunity to improve intersection safety, since 44% of all crashes in the U.S. occur at intersections¹, even though intersections represent only a small fraction of the roadway infrastructure in the United States.

Intersection crossing path crashes have been classified according to the relative movements of the conflicting vehicles and fall into the following six categories:

1. Left Turn Across Path – Opposite Direction (LTAP/OD)
2. Left Turn Across Path – Lateral Direction (LTAP/LD)
3. Left Turn Into Path (LTIP)
4. Right Turn Into Path (RTIP)
5. Straight Crossing Path (SCP)
6. Other/Unknown

These are illustrated in Figure 12.1 below.

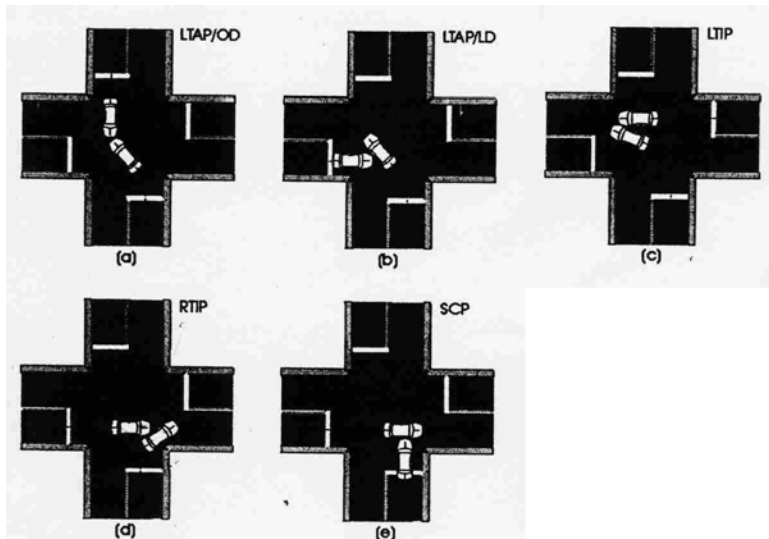

Figure 11.1 Intersection Crossing Path Crash Types

¹ Najm, W.G. and J. Koopmann, “Analysis of Crossing Path Collision Countermeasure Systems.”
September, 2000

When vehicles approach an intersection at crossing paths, it is usually not possible for sensors installed on the vehicles to detect the potentially conflicting vehicles, because they are generally not within line of sight until very shortly before their conflict.

Wireless communications among approaching vehicles could potentially overcome some of the line-of-sight problems, but in high-density urban environments, multipath issues along with some occlusions may diminish the effectiveness, and power control and message rate control techniques may need to be invented in order for the network to adjust to changes in node density. The center of the intersection, by contrast, has line of sight to all approaching legs of the intersection and can therefore serve as a relay point for communications among approaching vehicles, and this may be supplemented by an intersection infrastructure that could also detect all approaching vehicles. This indicates the opportunities that could be gained by combining infrastructure- and vehicle-based technologies to identify impending crossing-path conflicts and to provide information to drivers to help them avoid these conflicts.

The available intersection safety statistics, reviewed and synthesized into potential implications for CICAS in Section 2 below, shed light on the relative importance of the different types of intersection conflicts and how these might be addressed and helps establish priorities for the types of conflicts to address at each type of intersection and for determining which combination of countermeasures to apply at each intersection. In addition, we show that the SCP, LTAP/OD and LTAP/LD conflicts, which have been the primary focus of the current research of the IDS project under the IVI Infrastructure Consortium, account for the large majority of the intersection crossing-path crashes.

There is a difference between signalized intersections and intersections controlled by stop signs. At signalized intersections, the traffic signals are designed to ensure that straight crossing path (SCP) conflicts cannot occur unless a driver violates a signal. Therefore, the signal violation warning countermeasures are the primary means of addressing SCP conflicts at signals. Protected left-turn signal phases are designed to avoid LTAP/OD conflicts, but many intersections do not warrant these additional phases, and in many additional places there is insufficient space available to provide a protected left turn lane, or the additional signal phase would adversely impact intersection capacity. In these cases, an LTAP/OD conflict alert or decision support system would be the primary crash countermeasure.

The LTAP/LD conflicts are primarily associated with stop-sign controlled intersections, and in these cases an LTAP/LD conflict alert or decision support system would be the primary crash countermeasure. SCP conflicts at stop signs would generally be caused by stop sign violations, so violation warning countermeasures would be the primary means of addressing these. However, SCP conflicts could also result from driver errors in gap judgment at two-way stop signs, in which case the LTAP/LD countermeasure would apply.

This subdivision of intersection conflicts indicates the potential synergies in pairing CICAS countermeasures for each type of intersection:

- Signalized intersection – violation warning and LTAP/OD conflict alert
- Stop-sign controlled intersection – violation warning and LTAP/LD conflict alert.

It is useful to note that the hardware and software that will be needed to implement these pairs of countermeasures should be largely the same for a given intersection type. These will include means to implement the functions of upstream detection of approaching vehicle locations and speeds, target tracking, conflict prediction and wireless communication to/from approaching vehicles. The technical requirements for implementing violation warnings and turning conflict alerts are likely to be very similar for a given intersection. This means that both types of countermeasure can generally be achieved for the cost of one complement of equipment. The only difference is likely to be in the DII to display the relevant information to the approaching drivers.

The primary purpose of the CICAS should be avoiding intersection collisions. However, the CICAS countermeasures can also be designed so as not to unduly impede traffic flow. This is actually a potentially significant advantage that CICAS can have relative to more conventional traffic engineering approaches, which are more likely to limit intersection capacity in space-constrained locations (taking away a through lane for a protected turn lane, or taking away signal cycle time for a protected turn phase or all-red interval). If the CICAS alert criteria are carefully gauged to help drivers avoid unsafe encounters, but are not overly conservative about “borderline” encounters, they may even increase intersection capacity by helping drivers better distinguish acceptable turning gaps from unacceptable gaps.

Crossing path crashes are the primary focus of attention within CICAS, but it is also important to not overlook the other types of crashes that occur at and near intersections so that we do not inadvertently cause them to increase. Rear-end crashes are particularly common near intersections (representing 32% of all intersection crashes), when drivers

make incompatible judgments about stopping for signal phase changes or when they unexpectedly encounter queues of stopped vehicles. The design of the CICAS countermeasures needs to take care to not exacerbate this significant crash phenomenon, which is already being addressed by vehicle-based forward collision warning systems, even if it is not explicitly aiming to counter it.

11.2 Hypotheses about Crash Causality

The CICAS program is intended to use cooperative systems to reduce a significant proportion of crossing path (CP) crashes at intersections. The essential goal of the program is to design and demonstrate the effectiveness of systems that will provide crucial information to drivers, helping them avoid such crashes. Before effective systems can be designed, it is important to understand as much as we can about the causes of the crashes that we are trying to help drivers avoid.

Using the 2000 GES, the following general understanding of intersection crashes can be developed to guide future activities, based on the results previously reported in our Task A report under the IDS project (“Delineate Intersection Crash Problem”).

Findings and, highlighted in boxes, implications for CICAS, include:

2. Junctions are High-Risk Sites for Crashes

Crashes at junctions overall (defined as the connection of two roadways) represent about 60 percent of U.S. crashes, and most of these (or about 44% of all crashes) occur at intersections (a specific type of junction). Because junctions (and intersections in particular) represent a very small proportion of all streets and highways, they carry a much higher risk for crashes than other types of street or highway segments. Therefore, safety enhancements at such sites would be an efficient investment.

Specifically, CICAS countermeasures designed to prevent crashes at junctions in general, and intersections in particular, could efficiently address a significant share of all traffic crashes.

3. Crossing Path Crashes are a Significant Problem

Crossing path crashes represent 25 percent of all U.S. crashes²⁹. Types of crossing path crashes include:

- straight crossing path crashes (SCP) (8.6 percent);
- left-turn across path, opposite direction crashes (LTAP-OD) (6.7 percent);
- left turn across path, lateral direction crashes (LTAP-LD) (4.8 percent);
- right turn into path crashes (RTIP) (1.5 percent);
- left turn into path crashes (LTIP) (1.5 percent);
- other types of crossing path crashes (2.0 percent).

While each type of crash represents different pre-crash vehicle movements and a different mix of causal factors, each type could be reduced by using CICAS countermeasures to support driver decisions at intersections and other junctions.

3. Most Intersection Crashes Occur at Controlled Intersections

We found that among intersection crashes, most (74 percent) occurred at intersections with some type of traffic control device in place, including 46 percent at signalized intersections, 16 percent at two-way stop-sign intersections, 6 percent at four-way stop sign intersections, and 5 percent at intersections with some other type of control.

CICAS approaches should be compatible with existing traffic control devices, since these are already in use and well recognized by drivers.

4. *Many Crashes Occur at Uncontrolled Intersection Approaches*

About one quarter (26 per cent) of intersection crashes occur at intersections with no physical traffic control devices or in the uncontrolled direction of intersections with two-way stop sign controls. While statutory controls may apply at these intersections, the GES codes them as “uncontrolled”.

If “uncontrolled” intersections have such light traffic that they don’t even warrant a physical control device, or only warrant a two-way stop, there would probably be no justification for an infrastructure installation, and it appears that collisions at these intersections are best addressed by vehicle-based (and not cooperative) systems.

5. *Types of Crashes at Intersections Vary by Type of Traffic Control*

Crash types at intersections differ substantially by type of traffic control configuration.

- The majority of crashes at signalized intersections are LTAP-OD, SCP, and rear-end crashes (73 percent).
- The majority at two-way stop intersections are SCP and LTAP-LD (71 percent).
- The majority at four-way stop intersections are SCP and rear-end crashes (59 percent).

The differences represent the impact of traffic control on vehicle flow and reflect varying pre-crash vehicle movements. CICAS approaches will need to address the different patterns of crash types occurring with different traffic control configurations.

6. *Driver Errors are Primary Causal Factors in Intersection Crashes*

Based on police reports, driver failure is the most frequently identified causal factor in crashes, including failure to see crucial information (e.g., obstruction of view, driver distraction); and failure to correctly judge available information (e.g., misjudged speed of or distance to another vehicle).

CICAS should be designed to address both of these cases by increasing the salience and relevance of information available to drivers about potential risks as they navigate the intersection.

7. *Most Crashes Occur at Moderate Speeds*

A substantial proportion of intersection crashes takes place at intersections where speed limits are relatively moderate:

1. Almost 72 percent of crashes occur at intersections with speed limits of 40 miles per hour or less.
2. An additional 21 percent occur at intersections with speed limits between 40 and 55 miles per hour.
3. Only seven percent take place where the speed limit is 55 miles per hour or greater.

The fatality statistics are likely to be weighted more heavily toward the higher speeds, as Evans reports that a one percent increase in speed appears to increase fatality risk by 4% to 12%.³⁰

Even assuming that the average vehicle speed is higher than the posted speed, most intersection crashes are likely taking place at moderate speeds. This has implications for CICAS logic for detection of conflicts and for providing information to drivers, since vehicle speed has a strong influence on the assessment of threats.

8. *Older Drivers are Somewhat Over-Represented in Crossing Path Crashes at Intersections*

Most drivers in all crashes were under age 65. However, drivers age 65 and older represented 11 percent of crossing path crashes compared to 6.4 percent of non-crossing path crashes. There were virtually no gender differences by type of crash.

These results suggest that CICAS measures should be designed with potential functional limitations of older drivers in mind.

9. *Many Non-Crossing Path Crashes Occur at Intersections*

Rear end crashes make up about 32 percent of crashes at intersections, and crashes involving pedestrians and bikes about 3 percent.

While the CICAS project only addresses crossing path crashes directly, it is important to note the possible impacts of CICAS countermeasures on other types of crashes and to design them with the intent of not increasing the frequency or severity of those other crashes.

10. *CICAS May Reduce Risk Without Reducing Intersection Capacity*

Traditional traffic engineering countermeasures currently address crossing path crashes and other crashes at intersections. However, these countermeasures may

reduce intersection capacity, for example, by adding left–turn protection (substituting left turn lanes for through lanes) or increasing effective lost time per signal cycle, they may have other adverse affects, or they may fail to adequately meet informational needs of drivers.

CICAS countermeasures may be able to reduce risk for crossing path crashes at intersections by providing salient and relevant information to drivers, while maintaining intersection capacity.

11.3 A Concept of Operations for CICAS

CICAS provides an opportunity to make best use of the differing strengths of infrastructure and vehicle-based approaches to detecting and avoiding intersection conflicts. The keys to defining an effective CICAS concept of operations are maximizing flexibility and incorporating the ability to address the full range of intersection conflicts, including traffic control device violations and turning drivers' gap estimation errors, from the start. Fortunately, it appears to be possible to accomplish both of these goals without incurring extra costs or development delays.

Flexibility is important because of the wide diversity of intersections and of growth paths for each intersection. Intersections can be differentiated by:

- Urban, suburban or rural driving environments
 - Pedestrian and bicyclist density
 - Traffic speed and density
- Traffic volumes ranging from very high to very low
- Legacy traffic control infrastructure ranging from none to highly developed and sophisticated
- Geometric design constraints.

Any individual intersection could be operating at a variety of levels of sophistication over time, with different capabilities being added at different times. This means that the CICAS architecture should be able to accommodate the needs of that intersection throughout a logical growth path from stand-alone fixed-time signaling, through actuated and semi-actuated signaling and corridor or area-wide coordinated signaling, through to the implementation of additional detectorization for the purpose of identifying specific intersection conflicts. These intersections could also operate with varying degrees of cooperation with and from vehicles.

Infrastructure-based systems enjoy certain natural advantages for providing intersection collision avoidance support:

- Infrastructure-based displays can provide information to all drivers approaching the intersection, not just the drivers with the most capable vehicles;
- The center of the intersection has line-of-sight contact with all approach legs for purposes of sensing and wireless communications with approaching vehicles;
- By combining sensor or detector data with information from the traffic signal controller and information communicated from vehicles, the intersection infrastructure can know the complete state map of the intersection; and
- Investments in infrastructure installations can be prioritized based on the safety record of each intersection and its existing infrastructure, so that the first deployments can be targeted where they are likely to produce the maximum benefits.

Vehicle-based systems also enjoy a different set of natural advantages:

- The vehicle can know its own state (location, speed, acceleration and fault conditions) more accurately and earlier than an infrastructure-based sensor would be able to detect it;
- Vehicle-based alerts to drivers can be more salient than infrastructure-based alerts (using audible and haptic information channels as well as visual);
- Vehicle-based alerts can be integrated with other in-vehicle safety systems to save costs and to optimize driver workload demands under stressful conditions;
- If systems are introduced on a significant fraction of the new vehicles each year, it is possible to reach broad market penetration faster than by relying entirely on infrastructure systems.

Furthermore, future vehicle-based systems may take advantage of the following potential features:

- Driver patterns of past driving behavior and intentions (e.g., turn signals) can be detected and used to enhance the accuracy of conflict predictions;
- Vehicle-based alerts can be tailored to individual driver behavior and preferences, so that a single alert criterion does not need to satisfy the broad diversity of the driving population as a whole;

These strengths are largely complementary to each other, so that combinations of both vehicle and infrastructure elements should make it possible to expand the performance envelope of CICAS beyond what would be possible if vehicles and infrastructure were not coordinated with each other.

There are a limited number of distinct levels of information that could be communicated between the infrastructure and vehicles, and there is no reason why these should not be able to coexist at the same intersections and with the same vehicles. The same wireless communication channel should be able to serve the gamut of information exchange. The

intersection may broadcast any combination of the following dynamic (rapidly changing) information:

- Intersection ID, signal phase and timing to next phase change
- Relay of information supplied by approaching vehicles
- Data from infrastructure-based sensors
- Infrastructure-based intersection alert status.

In addition, the roadside unit could also broadcast static information describing the intersection geometry, but since that information does not change rapidly it does not need to be transmitted on a safety-critical, time-critical channel. The combination of the static and dynamic information that, when combined, fully characterizes the state of the intersection is referred to as the intersection “state map”. This includes the state of the signal system (current phase and timing to next phase change) plus the relevant state of all nearby and approaching vehicles (locations, speeds, accelerations and turning intentions if known).

Table 1 shows how different combinations of dynamic information could be broadcast from different intersections, or even from the same intersection but at different times. Each of these combinations of information could be accommodated within the same DSRC public safety (control) channel. It is not necessary to make an *a priori* decision requiring all intersections to provide the identical combination of broadcast data. Rather, if the standards and vehicle components are defined to accommodate the highest capability (column F in Table 1), any of the lower combination can continue to be provided as well.

Table 11-1 Alternative combinations of capabilities of intersection broadcasts of dynamic state map data

Combinations of Capabilities						
Capabilities	A	B	C	D	E	F
Intersection broadcasts signal phase and ID	X	X	X	X	X	X
Intersection broadcasts relayed vehicle data		X	X			X
Intersection broadcasts infrastructure sensor data			X	X	X	X
Intersection broadcasts infrastructure alert status				X		X

There are strong similarities between the intersection state map information needed to implement signal violation and turning conflict avoidance systems. Therefore, it makes sense to address them together rather than separately. Depending on the level of equipment installed at the intersection (which could involve wireless communications to broadcast the state of the traffic controller, additional sensors beyond those normally used for traffic control, or both), different levels of accomplishment could be reached for addressing signal violation and turning conflicts, as shown in Table 2 below.

It is therefore possible to define an inclusive CICAS concept of operations that can address both violation and turning conflicts with varying allocations of responsibility between the vehicle and infrastructure elements. No reasonable alternatives are precluded, and flexibility is provided to enable full interoperability among vehicles and intersections with widely varying levels of capability:

1. The intersection broadcasts its status (identifier, location, signal phase and timing to phase change) periodically (~100 ms update interval, for example) to all vehicles within range, and tells them the range within which they should respond.

2. The approaching vehicles within that range broadcast their status periodically until they clear the intersection, with their status being defined by an industry-standard message set of limited size and complexity³¹.
3. The intersection fuses the information it has received from its infrastructure-based detectors with the information received from nearby vehicles to produce its state map and to estimate potential conflicts.
4. The intersection broadcasts its state map, conflict status, and any alerts that it declares, and also displays its alerts on dynamic roadside signs (known as the driver-infrastructure interface, DII).
5. The vehicles decide what to display to their drivers, based on fusion of all information available to them from their onboard sensors, broadcasts from other vehicles and broadcasts from the intersection (state map and conflict status). They decide whether to rely on the infrastructure alert or to independently estimate their own alert.

Drivers of unequipped vehicles would be able to receive information from the DII at equipped intersections, and drivers of equipped vehicles might be able to receive information from their in-vehicle systems at intersections that are not equipped with a DII. Drivers of equipped vehicles may receive infrastructure-based and vehicle-based information at equipped intersections. Some attention needs to be devoted to ensuring that drivers are not confused by the two different sets of information, which may not be identical. A preliminary investigation of this issue by PATH under the current IDS project has indicated that this is unlikely to create safety problems.

Table 11-2 Addressing signal violation and turning conflict alerts with varying levels of infrastructure equipment

Infrastructure equipment to be added	Signal Violation Alert in		Turning Conflict Alert in	
	Vehicle	Infrastructure	Vehicle	Infrastructure
None	Limited	No	No	No
Communication w/o additional sensing	Yes	No	Very Limited	No
New sensing w/o communication	Limited	Yes	No	Yes
Communication and sensing	Yes	Yes	Yes	Yes

Alternative concepts of operations have been discussed among potential CICAS participants, and they span the spectrum from infrastructure-only (i.e., DII implementation, actuated by sensed information from infrastructure-based sensors) through mainly a vehicle-based cooperative system where the sole source of information required by the onboard processor would be the traffic signal state and countdown to phase change. The concept of operations discussed here bridges the gap and may realize a system that may take either (vehicle- or infrastructure-based) or both deployment paths.

11.4 System-Level Functional Requirements

Functional requirements for CICAS are defined in a hierarchical sequence, beginning with Section 4.1 at a higher level with output characteristics of the entire system that are needed to support the overall CICAS goals. These requirements then flow down to the lower-level subsystems.

The topmost function of the CICAS is to provide an appropriate alert to the driver in order to help him or her avoid an intersection conflict. The nature of that alert then drives the requirements that are imposed at the lower levels, eventually flowing down to the component technologies generally corresponding to those in the Task 2 report:

- detection and sensing
- driver interfaces
- information processing
- data interfaces between the infrastructure and vehicles, and
- cross-cutting issues.

The requirements identified here are intended to be generally applicable to intersection collision avoidance of all types unless otherwise specified. Some of the requirements are specific to the LTAP/OD conflicts at signalized intersections, since that has been the primary focus of the PATH work to date. This conflict is represented in Figure 2 below.

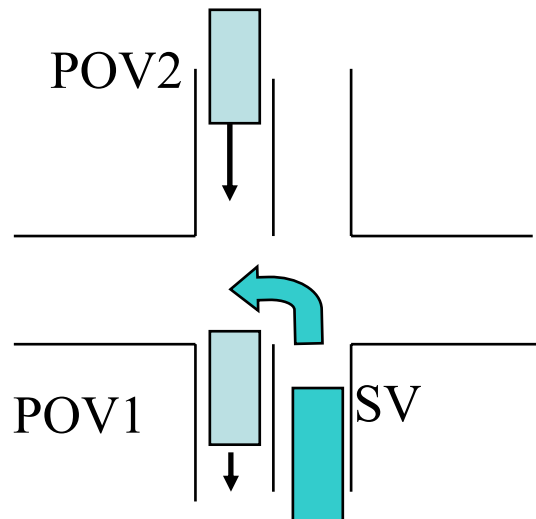

Leading buffer is behind POV1, ahead of SV
Trailing buffer is behind SV, ahead of POV2

Figure 11.2 Definition of Terms in LTAP/OD Conflict

11.4.1 CICAS Alert Generation Requirements to Support Overall Goals

Alerts regarding hazardous conditions should be issued under conditions that are perceived by drivers as potentially hazardous, such that the alerts are not disregarded or considered to be nuisances. *Observations of intersection turning behavior under the current IDS project are characterizing the turning behavior of the driving population in general so that the alert criteria can be established to be compatible with the expectations of the majority of the (safe) driver population.*

LTAP/OD alerts should be issued for trailing buffer gaps less than ~3 seconds (between when the rear of the turning vehicle clears the path of the approaching Principal Other Vehicle (POV) and when the front of that POV reaches the point of potential conflict with the turning vehicle), based on initial observation results. *This value will be tested during human factors experiments in the remainder of the current IDS project in order to produce a refined estimate.*

Alerts must be issued for the large majority of truly hazardous conditions in order to give drivers the opportunity to avoid conflicts and to convey assurance to the drivers that the warning system is reliable and consistent. *The specific percentage value that constitutes an acceptable “large majority” is a policy decision that needs to be considered by the relevant stakeholder community, not only based on technical considerations.*

The alert signal needs to be displayed to the driver early enough to enable the driver to make a comfortable (non-panicked) decision to respond by stopping or deferring the turning maneuver, but not so early that it leaves ambiguities about the identity of the specific driver for whom it is intended.

The LTAP/OD alert should be issued at least in time for the turning driver to be able to stop his vehicle comfortably before entering the zone of conflict with approaching POVs. This time is defined by providing for a typical 1 second driver perception-

reaction time plus the time needed to decelerate at a moderate rate (less than ~ 0.25 g) from the Subject Vehicle's (SV's) initial approach speed. *This will be tested during human factors experiments in the remainder of the current IDS project in order to produce a refined estimate of the most appropriate alert timing.*

The alerts must be perceived by drivers to be consistent and reliable for them to have confidence in the validity of the alerts and to respond to them effectively.

The threshold values of buffer time between SV and POV that trigger the LTAP/OD alert need to be consistent to within a tolerance of no more than TBD1 milliseconds. *This value needs to be determined based on human factors experiments.*

The time when the alert is issued to the SV driver needs to be consistent to within a tolerance of no more than TBD2 milliseconds relative to the SV's projected arrival at its stop bar. *This value needs to be determined based on human factors experiments.*

The CICAS alert system should not create unintended consequences in terms of impeding traffic flow at intersections by discouraging turns that can be made safely.

LTAP/OD alerts should not be issued for turns that would occur with trailing buffers longer than ~ 4 seconds. *This value should be refined based on the human factors experiments planned for the remainder of the current IDS project.*

The CICAS alert system should not exacerbate other types of crash conflicts, such as rear-end crashes, by issuing alerts that could elicit sudden surprise decelerations by drivers unless an imminent and severe crossing-path conflict is detected with high confidence.

The CICAS alert system design needs to be adaptable to diverse intersection conditions, including geometric design, signaling, vehicle and pedestrian traffic density, prevailing approach traffic speed, plus weather and visibility conditions. *It is expected that the parameters of the alert criteria will need to be adjusted based on the conditions at each*

specific intersection. Definition of these adaptation factors should be one of the primary research goals for the CICAS program.

The CICAS design needs to be suitable to address all relevant intersection conflicts (based on traffic control device violations and left and right turns) using a consistent complement of equipment (detectors, computer, traffic controller, wireless communication devices) in order to minimize costs and maximize efficiency.

CICAS for use in urban and suburban areas should be designed to enhance the safety of pedestrians and bicyclists as well as drivers. This means that they need to be able to detect the presence and movement of pedestrians and bicyclists and adjust the alerts displayed to drivers so that they can avoid conflicts with these vulnerable road users.

11.4.2 Requirements for Detection and Sensing Derived from Section 4.1

Measurements of threat conditions need to be sufficiently consistent that the measured buffer gap threshold value used to trigger an LTAP/OD alert is accurate to within TBD3 milliseconds (derived from 4.1.4). This requirement affects the combination of accuracy and latency of the vehicle detection measurements, since the buffer gap measurement (estimate) error is the sum of the latency plus the ratio of the distance to the speed measurement errors.

Movements of POVs in an LTAP/OD conflict need to be detected at least 6 seconds prior to their arrival at the intersection (derived from 4.1.3). This allows for the ~3 second trailing buffer time defined in 4.1.1.1 plus the ~3 second SV turning time observed during the IDS project studies. Note that this means that the detection range for a specific intersection should be proportional to the speed of the fastest traffic approaching the intersection.

Movements of turning SVs in an LTAP/OD conflict need to be detected far enough from their arrival at the intersection stop bar to allow for conflict prediction and

issuance of an alert early enough for the SV to decelerate to avoid the conflict as defined in Section 4.1.3.1. This detection range for a specific intersection therefore depends on the speed of the fastest approaching vehicles that are planning to make left turns there.

Measurement and data fusion processes need to have combined detection and signal processing latency of less than TBD6 milliseconds (derived from 4.1.3 and 4.1.4). The specific value of TBD6 will need to be defined through a design trade-off with the detection range and accuracy as well. *Preliminary values will be defined in simulation studies during the remainder of the IDS project, but experimental verification of the values will require further work in the CICAS program.*

11.4.3 Requirements for Driver Interfaces (DII, DVI) Derived from 4.1

The CICAS display needs to be easy for drivers to see and understand quickly in a high-workload intersection driving environment, but not so obtrusive that it would be distracting. This affects the location, brightness and visual design of the display.

The location of the roadside DII will be constrained by physical limitations of specific intersection geometric layouts, which are likely to vary greatly. *General guidelines for DII location will be defined based on the human factors experiments underway in the current IDS project.*

The visual design of the DII is directly coupled with the concept of the type of information to be provided to the driver. *An initial concept of the information display is being tested in the current IDS project, but the final selection will have to depend on the results of the human factors experiments during the remainder of this project. The concepts for the different types of intersections and conflicts will need to be harmonized in the CICAS program in order to avoid driver confusion.*

The ultimate DII implementation concept(s) will have to be based on what can gain approval from the relevant MUTCD approval committees.

11.4.4 Requirements for Information Processing Derived from 4.1

LTAP/OD conflicts need to be estimated early enough that the relevant alerts can be displayed to the SV driver at least TBD7 seconds before the projected SV arrival at its stop bar (derived from 4.1.3.1).

11.4.5 Requirements for Data Interfaces (to traffic signal controllers, wireless to/from vehicles) Derived from 4.1

CICAS designs that employ combinations of infrastructure- and vehicle-based components should apply these elements so that they complement each other effectively. If they provide alert displays to the drivers from both the infrastructure and the vehicle, the content and timing of these displays should be designed to be sufficiently consistent that they do not confuse or distract the driver.

Since the in-vehicle systems can provide graduated alerts, one level of the in-vehicle graduated alert could be synchronized with the infrastructure-based alert, while the other levels could be used to provide a richer range of alternatives.

The CICAS for use at signalized intersections need to be compatible with the installed base of traffic signal controllers and cabinets in current use (electrical, software and mechanical compatibility). This is likely to require diverse CICAS implementations in order to accommodate the considerable variability of installed traffic control systems.

Data communications between vehicles and intersections will need to be based on well-defined national standards covering all applicable layers of the communications protocol stack. *These should not be unique for CICAS applications, but should be elements within a broader vehicle safety communications framework.*

11.4.6 Cross-Cutting Requirements Derived from 4.1 and Costs, Based on Compatibility with CICAS Goals

Reliability of CICAS hardware and software combined needs to exceed TBD8 (derived from 4.1.2, and therefore based on the same policy considerations).

Availability of CICAS hardware and software combined needs to exceed TBD9 (derived from 4.1.2, and therefore based on the same policy considerations).

The installation and maintenance costs of the CICAS need to be cost-effective when compared to other alternatives for reducing intersection conflicts.

The installation cost for the infrastructure elements of a CICAS should not exceed TBD10 dollars for a typical mid-size intersection with two through lanes in each direction. *This value will have to be defined based on effectiveness in reducing intersection crashes and competitiveness with more conventional alternatives, following experience with field operational testing.*

The annual operating and maintenance costs for the infrastructure elements of a CICAS should be about the same percentage of the installation costs as traffic engineers would expect for conventional traffic control equipment, in order to facilitate acceptance within the traffic engineering community.

The requirements that have been defined here are based on current and continuing research under PATH's IDS project. Since the work on the tasks that have contributed to these results is ongoing, it has not yet been documented in project reports. As the above text has indicated, some of the requirements will be refined and updated based on the remaining work to be done under the IDS project, and other requirements will be defined initially based on that remaining work.

GLOSSARY

Definitions for IDS Simulation

This document describes terms that are used in a specialized sense in the IDS simulation documents. Definitions of intersection safety terms in general use can be found in <http://PATH.Berkeley.EDU/~vjoel/ssm/ssm-web/www.tfhr.gov/safety/pubs/03050/>. In particular, see <http://PATH.Berkeley.EDU/~vjoel/ssm/ssm-web/www.tfhr.gov/safety/pubs/03050/02.htm#sect2a>.

World

A completely specified set of modeled entities (vehicles, drivers, sensors, etc.), including their initial state and their evolution over time. Corresponds to a simulation run; two runs of the same world should produce identical results, though there may be some small variation due to integrator step, for example. A world consists of a [scenario](#) and a [countermeasure](#). A particular run of a world involves the creation of certain software objects, including [components](#) and other objects which are not reactive (data logs, for instance), and the advancement of time in fixed increments until a certain goal (a time, typically) is reached.

Scenario

The set of entities in a [world](#) whose behavior constitutes the threat of collision. Includes their initial state and their evolution over time. Includes any factors contributing to the threat of collision, such as rain, visibility, driver characteristics, etc.

Countermeasure

The set of entities in a [world](#) that are designed to detect and prevent a collision. This includes physical entities such as sensors, as well as algorithms such as

sensor fusion, warning time selection, etc. The countermeasure may or may not feed back into the simulation through a warning interface to the driver and a model of driver reaction.

Experiment

A set of *worlds* (that is, a set of pairs each consisting of a *scenario* and a *countermeasure*), along with a specification of the measurements to be made for each of the worlds. Typically, an experiment will include *every* pair with the scenario drawn from one set and the countermeasure drawn from another.

POV

Principal Other Vehicle—a vehicle which threatens to collide with the *SV*. Speaking loosely, there can be more than one *POV*.

SV

Subject Vehicle—a vehicle approaching the intersection which intends to maneuver through a *conflict region* in which another vehicle has right of way.

Conflict region

The intersection in space of the paths or potential paths of two or more vehicles.

Explicit trajectory

A vehicle trajectory defined by a sequence of points at which the vehicle accelerates or decelerates. Each point is defined in terms of a condition and an acceleration value to apply when the condition becomes true. The condition can, for example, be specified in terms of distance from the vehicle's starting point, time since starting, distance to the intersection (*D2I*), or (kinematic estimate of) time to intersection (*T2I*). Trajectories involving velocity changes (rather than acceleration changes) can be approximated using high accelerations for short periods of time.

T2I

Kinematic estimate of arrival of the front bumper of the approaching vehicle at stop line, assuming no change in speed; a continuous function of time defined by $T2I(t) = (t) / \text{speed}$.

D2I

Distance from the front of the approaching vehicle to the stop line.

Component

A software object in a run of a [world](#) which reacts to the advancement of the world clock and to the actions of other components in the simulation. A component is often, but not always, an implementation of a [model](#), or part of such an implementation. Components can be thought of as processes running in parallel during the execution of a world. Components can have both continuous and discrete state variables.

Model

A mathematical representation of some physical entity or process, described in terms of equations, logical rules, parameters, etc. Often implemented in a simulation as a [component](#) or as a network of components.

Queue

A sequential data structure with two ends: data is added at one end and removed from the other. Typically, each end of the queue is managed by a different process (such as a component), and the queue is used as a first-in, first-out communication channel between the two processes.

Event

A message between two components that persists only during an instant of time. An event may carry arbitrary data, or it may be significant merely for its presence. Events are used to synchronize between processes (such as components) running

in parallel, and to communicate discrete data, rather than continuously changing data. Events are a “pull” model of interaction, as opposed to “push”, in the sense that the receiver must take initiative to ask the sender for the event—the event does not force the receiver to take action.

Perfect information

A simulation design in which the warning system receives the entire time-history of the dynamical variables of the vehicles in the simulation and uses this information to determine the ideal warning period(s). Compare [*perfect sensing*](#).

Perfect sensing

A simulation design in which the warning system receives true values, moment to moment, of the dynamical variables of the vehicles in the simulation and uses this information to determine, moment to moment, whether to issue or retract the warning. Compare [*perfect information*](#).

DII – Driver-infrastructure interface – An infrastructure-mounted visual display to provide information to the driver of any approaching vehicle.

DVI – Driver-vehicle interface – An in-vehicle display (visual, auditory and/or haptic) to provide information to the driver of that vehicle.

GES – General Estimate System – Database of traffic safety statistics

IDS – Intersection Decision Support – A system to provide information to drivers to help them make safer driving decisions at intersections, and the name of a project of the IVI Infrastructure Consortium to develop the system.

LTAP/LD – Left turn across path/lateral direction intersection conflict

LTAP/OD – Left turn across path/opposite direction intersection conflict

POV – Principal other vehicle – A vehicle approaching an intersection that is in potential conflict with the subject vehicle.

SCP – Straight crossing path intersection conflict

SV – Subject vehicle – The vehicle approaching an intersection with the assistance of information from an IDS or CICAS system. Its driver may be planning to turn or may be on the verge of violating a traffic control device, and therefore in need of assistance.

TBDn – To be determined – Numerical values that are not yet defined, but that should be defined based on ongoing research within the IDS project.

Trailing buffer time – The time interval between (a) when the rear end of a turning SV clears the path of the first approaching POV and (b) when the front of the first approaching POV reaches the path of the turning SV.

Appendix A. Radar Configuration and Coordinate Transformation

A.1. Radar Specifications

Product Manufacturer	Eaton – VORAD Technologies, LLC
Model Number	EVT-300
Type & Frequency	Doppler at 24.75 GHz
Range	1-106 meters (3-350 feet)
Range Rate	0.28-45.45 m/sec (0.50-100 mph)
Field of View	12 degrees
Number of Targets	7-20
Accuracy	5% ± 3 ft, 1% ± 0.2 mph, ± 0.2 degree
Power Requirements	12-24 V, 20 watts
Transmitted RF Power	3.0 milliwatts
Temperature Range	-40 to +185 F

A2. Coordinate System Transformation

The measurements from EVT-300 are expressed in a polar coordinate frame, (r, δ) , centered at the origin or the location of the radar antenna. r is the radial distance from the antenna to the detected target, while δ (azimuth angle) is the angle between the antenna centerline (boresight) and the target.

For a measured point in the polar coordinate frame, (r, δ) , an alternative representation is to express it in a conventional, Cartesian coordinate frame (x_r, y_r) , where the local coordinates are defined as

$$\mathbf{r} = (x_r, y_r) = (r \cos \delta, r \sin \delta)$$

and the velocity may be expressed as

$$v = \sqrt{\dot{x}_r^2 + \dot{y}_r^2} = \sqrt{\dot{r}^2 + (r\dot{\delta})^2}$$

To transform the measured point into a global frame (X_g, Y_g) a rotation and translation conversion may be applied,

$$\begin{bmatrix} X_g \\ Y_g \end{bmatrix} = \begin{bmatrix} X_{rg} \\ Y_{rg} \end{bmatrix} + \begin{bmatrix} x_r \\ y_r \end{bmatrix} \begin{bmatrix} \cos \alpha & -\sin \alpha \\ \sin \alpha & \cos \alpha \end{bmatrix}$$

where (x_r, y_r) is the location expressed in the local frame with the origin at the radar antenna. The vector $\mathbf{r}_{rg} = (X_{rg}, Y_{rg})$ is the relative location of the local origin expressed in global coordinates, and α is the rotation angle between the local and global frames. See Figure A.1.

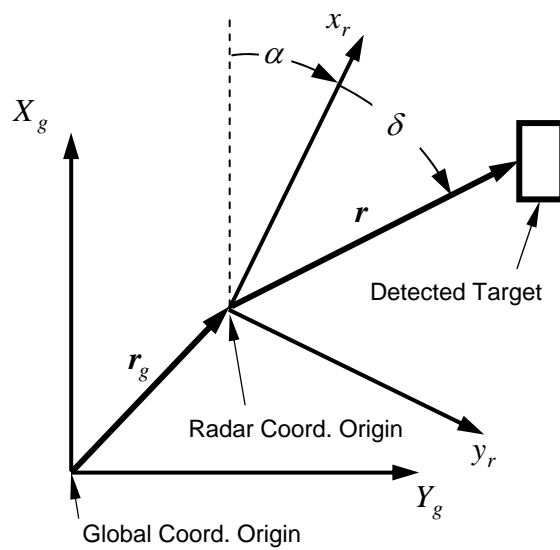

Figure A.1. Coordinate Systems for Radar Measurements.

APPENDIX B. DISTRIBUTION OF TYPES OF SV LEFT TURNS OBSERVED

Type of left turn	Alameda/Marin		Brannan/Fifth		San Pablo, Pinole		Hearst and Shattuck		El Camino Real		TOTAL	PERCENTAGE
	Number of Observations	Percentage	Number of Observations	Percentage	Number of Observations	Percentage	Number of Observations	Percentage	Number of Observations	Percentage		
Pedestrians	0	0.0%	6	4.8%	1	1.4%	22	20.2%	9	3.4%	38	4.2%
On the Fly	86	25.6%	8	6.4%	21	29.2%	16	14.7%	31	11.8%	162	17.9%
From Queue	110	32.7%	26	20.8%	7	9.7%	11	10.1%	38	14.4%	192	21.2%
Yellow or Red	99	29.5%	71	56.8%	0	0.0%	27	24.8%	9	3.4%	206	22.8%
Other**	103	30.7%	23	18.4%	43	59.7%	41	37.6%	177	67.3%	387	42.8%
Overall	336	100%	125	100%	72	100%	109	100%	263	100%	905	100%

* Time from first significant turning to clearing POV lane

** Waiting for gap during green with no pedestrian present

Appendix B-2 Turning times for SV left turns by type of turn

Type of left turn	Alameda/Marin Time of observation: 121 min			Brannan/Fifth Time of observation: 157 min			San Pablo, Pinole Time of observation: : 108 min			Hearst and Shattuck Time of observation: 202 min			El Camino Real Time of observation: 159 min			Average	Standard Dev
	Number of Observations	Average	Standard Dev	Number of Observations	Average	Standard Dev	Number of Observations	Average	Standard Dev	Number of Observations	Average	Standard Dev	Number of Observations	Average	Standard Dev		
Pedestrians	0	-	-	6	6.4	2.7	1	3.3	-	22	4.4	1.5	9	3.9	1.1	4.6	1.8
On the Fly	86	2.2	0.3	8	3.5	0.4	21	2.6	0.4	16	2.8	0.5	31	2.6	0.5	2.4	0.5
From Queue	110	2.5	0.6	26	4.1	0.8	7	4.3	1.0	11	3.1	0.4	38	3.3	0.8	3.0	0.9
Yellow or Red	99	2.9	1.3	71	4.3	1.2	0	-	-	27	2.9	0.5	9	2.8	0.2	3.4	1.3
Other**	103	2.8	1.3	23	3.8	0.8	43	3.4	0.6	41	3.1	0.5	177	3.2	0.8	3.1	0.9
Overall	336	2.6	1.0	125	4.4	1.4	72	3.2	0.7	109	3.3	1.0	263	3.1	0.8	3.1	1.1

* Time from first significant turning to clearing POV lane

Appendix C: Specifications of Tested Products

3M Canoga Microloops

Product Manufacturer	3M
Type & Frequency	Inductive microloops
Dimensions	.88” outside diameter and 3.63” long
Temperature Range	-35° F to +165° F (-37° C to +74° C)

Sensys VDS240 Specifications

Product Manufacturer	Sensys
Model Number	VDS240
Type & Frequency	Active Magnetic
Range	120 meters (393.6 feet)
Update Rate	128 HZ/node
Latency in Communication	0.1 second
Number of Targets	1
Power Requirements	Beterries

Sensys VDS240 Timing Scheme

The timing scheme is organized as follow.

1. There is a 30 second superframe that is subdivided into 30 frames of one second duration each.
2. Each one second frame is again subdivided into eight sub-frames of 125milliseconds (msec).
3. Each 125msec sub-frame is in turn subdivided into 64 time slots. Each sensor node is assigned a time slot in each 125msec sub-frame to transmit its events to the AP.

This means that an event is transmitted to the AP within 125msec of its occurrence and unless there is transmission error the maximum delay between the time an event occurs and the time the sensor node (SN) starts transmitting to the AP is 125msec.

At the beginning of each frame the AP sends the frame number as an ASCII string starting with * followed by the frame number (in hexadecimal): *01, *02, *03, ..., *1D, *1E to the PC over the serial port. At the end of the 30-frame superframe the frame number is reset to *01 for the beginning of the next superframe.

Each sensor node clock is synchronized to the clock of the AP and records event times in (1/1024) of a second from the beginning of the superframe. This time stamp is an absolute time value that can be used by the PC to determine the exact time the event occurred, independent of any transmission latency. The event reporting word (2 bytes) is defined as follows:

Bit 0: Present/Not present

Bit 1-5: Frame in superframe (starting at 0)

Bit 6-15: Time in (1/1024) msec from beginning of the frame

Two special events 0x7FFF and 0xFFFF correspond to “no event” which is transmitted after each two-second interval with no included events.

The transmission latency (TL) has four components:

TSN: Transmission delay in the sensor node which is less than or equal to 1 sub-frame of 125msec

P: Propagation delay which for the distances involved is negligible

TAP: Transmission delay in the AP over the serial port which is less than one packet time (2ms)

RTSN: Re-transmission delay which occurs if there is transmission error and the packet needs to be retransmitted: 125msec x number of retransmissions

$$TL = TSN + P + TAP + RTSN$$

In case of no packet error the total latency is approximately $TL = TSN + TAP = 127\text{msec}$

For each retransmission the delay is increased by 125msec

Traficon Video Detection Specifications

Product Manufacturer	Traficon
Type & Frequency	Video Detection
Dimensions	160*100*41 mm 19" rack compatible Euro Board
Power Requirements	+5V dc (600mA) to +26V dc (150mA)
Temperature Range	-34° C to +74° C
Product Manufacturer	EIS
Model Number	RTMS
Type & Frequency	Microwave radar
Range	3-60 meters (10-200 feet)
Elevation angle	45 degrees
Detection zones	Up to 8 zones
Zone width	2 – 7 meters (7 – 20 feet)
Power Requirements	12 - 24 Volt AC or DC @ 4.5W; 115 VAC option
Temperature Range	-37° to + 74°C
Dimensions	16 x 24 x 12 cm (6 x 9 x 5 inches)

Endnotes

¹ Based on 1998 GES data, crossing-path crashes are estimated at 27 percent of the total. The 25 percent estimate from GES 2000 data is within the range due to sampling variation.

² Chan, C-Y, Marco, D., Misener, J., *Threat Assessment of Traffic Moving Toward A Signal-Controlled Intersection*, IEEE 2004 Intelligent Vehicle Symposium, Parma, Italy, June 2004.

³ Chan, C-Y, Marco, D., *Traffic Monitoring at Signal-Controlled Intersections and Data Mining for Safety Applications*, the Proceedings of the IEEE 2004 Intelligent Transportation System Conference, Washington D.C., October 2004.

⁴ Shladover, S.E., et al., “Measuring Intersection Turning Behavior to Support Design of an Intersection Collision Warning System”, *ITS World Congress*, Nagoya, Japan, October 2004.

⁵ Chan, C-Y, et al., *Observations of Driver Time-Gap Acceptance at Intersections in Left-Turn Across-Path Opposite Direction Scenarios*, 2005 TRB Annual Meeting, Paper No. 05-2159.

⁶ Ragland, D., et al., “Impact of Pedestrian Presence on Movement of Left-Turning Vehicles: Method, Preliminary Results & Possible Use in Intersection Decision Support,” 2005 TRB Annual Meeting, Paper No. 05-2199.

⁷ Shladover, et al., “Design of Alert Criteria for an Intersection Decision Support (IDS) System,” 2005 TRB Annual Meeting, Paper No. 05-2516.

⁸ Chan, C-Y, “Traffic Characterization and Risk Assessment of Intersection Left-Turn Across-Path Conflicts Based on Field Observation,” submitted to *IEEE Transactions on Intelligent Transportation Systems*, February 2005.

⁹ Staplin L. (1995) Simulator and field measures of driver age differences in left-turn gap judgments. *Transportation Research Record* 1485 49-55.

¹⁰ Alexander J. Barham P. and Black I. (2002) Factors influencing the probability of an incident at a junction: results from an interactive driving simulator. *Accident Analysis and Prevention* 34 779-792.

¹¹ Olson P. L. (2002) Driver Perception-Response time Chapter 3 in *Human Factors in Traffic Safety*, R. E. Dewar and P.L. Olson eds, Lawyers and Judges Publishing company, Inc. Tucson.

¹² More precisely, a “gap” is length of time between two POVs and a “lag” is the time between an opportunity to turn [e.g., green light, arrival at the intersection] and the arrival of a POV). In this report the term gap will be used to describe both, i.e., referring to the time available to turn before a POV arrives.

¹³ Homburger, Hall, Reilly, and Sullivan. *Fundamentals of Traffic Engineering*, 15th Edition. Institute of Transportation Studies, University of California, Berkeley, January 2001.

-
- ¹⁴ The concepts of “gap” and “lag” are related in that they both represent the time available for an SV to turn. In this report they will be collectively referred to as “gaps.”
- ¹⁵ Archer, Jeffery. Developing the potential of micro-simulation modeling for traffic safety assessment. Centre for Traffic Simulation Research (CTR). Proceedings ICTCT Conference, Corfu 2000. p. 6-7.
- ¹⁶ Statewide Integrated Traffic Records Systems (SWITRS), California Highway Patrol (CHP), 2005.
- ¹⁷ VanderWerf J. Overview: Sensor and warning system evaluation tool, March 2005
<http://path.berkeley.edu/IDS/EvalTool/>
- ¹⁸ Gettman D, Head L. Surrogate Safety Measures from Traffic Simulation Models, Final Report. Turner-Fairbanks Highway Research Center, Federal Highway Administration. Pub. No. FHSA-RD-03-050. January 2003
<http://path.berkeley.edu/~vjoel/ssm/ssm-web/www.tfrc.gov/safety/pubs/03050/>
- ¹⁹ As described above, the term “gap” is used to defined the time available to turn, either the time between two POVs (usually called “gap”) or the time after an opportunity to turn (e.g., green light, arrival at intersection) and the arrival of a POV.
- ²⁰ For most of the analyses in this report, times were aggregated into one second intervals. A reference to a particular second refers to the integer defining the low end of the interval. For example, 2 seconds refers to the interval 2-3 seconds, etc.
- ²¹ Homburger, Hall, Reilly, and Sullivan. Fundamentals of Traffic Engineering, 15th Edition. Institute of Transportation Studies, University of California, Berkeley, January 2001. Platooning refers to the tendency for vehicles to move in clusters. p. 4-7, 4-8
- ²² (<http://mathworld.wolfram.com/LogNormalDistribution.html>).
- ²³ Hearst and Shattuck was the first intersection analyzed, and gaps below 3 seconds were not measured.
- ²⁴ Ibid. p. 4-9. Note that the gap acceptance curve goes from 0 to 1 (or 0 to 100%), it is not a cumulative curve, but simply indicates the probability that a gap will be accepted for a give gap length.
- ²⁵ Bellomo-McGee Incorporated (BMI). Intersection Collision Avoidance Study. Final Report. September, 2003.
- ²⁶ Miller, R Jerry. Step-by-step examples. GraphPad PRISM Version 4.0. p 121-137
- ²⁷ “The Use of Video Detection at Signalized Intersections.” *The Urban Transportation Monitor* December, 2004: 10-14.
- ²⁸ Latency refers to the total discrepant time (the sum of A – B) between a trigger of the loop (A) and registry of the detection by the controller (B).
- ²⁹ Based on 1998 GES data, crossing-path crashes are estimated at 27 percent of the total. The 25 percent estimate from GES 2000 data is within the range due to sampling variation.
- ³⁰ Evans, L., *Traffic Safety: Science Serving Society*, Bloomfield Hills, MI, 2004, p. 216.
- ³¹ During the IDS project, steps 1 and 2 were partially demonstrated by a PATH-DaimlerChrysler team.