

**CAMP**

***Vehicle Safety Communications 2***



Mercedes-Benz

Research & Development North America, Inc.  
A Daimler Company



**TOYOTA**

**HONDA**

Honda R&D Americas, Inc.



***Intelligent Transportation Systems***

***Vehicle Safety Communications – Applications  
VSC-A***

**First Annual Report  
December 7, 2006 through December 31, 2007**

*Submitted to the Intelligent Transportation Systems (ITS)  
Joint Program Office (JPO) of the  
Research and Innovative Technology Administration (RITA) and the  
National Highway Traffic Safety Administration (NHTSA)*

*September 4, 2008*

*In Response to Cooperative Agreement Number  
DTNH22-05-H-01277*

# Table of Contents

<b>1</b>	<b>Introduction.....</b>	<b>1</b>
<b>2</b>	<b>Task 1 Summary: Program Management .....</b>	<b>2</b>
<b>3</b>	<b>Task 2 Summary: Coordination with Standards Development Activities and Other USDOT Programs.....</b>	<b>5</b>
	3.1 IEEE 1609.x: .....	6
	3.2 IEEE 802.11p: .....	6
	3.3 SAE DSRC J2735: .....	7
<b>4</b>	<b>Task 3 Summary: Vehicle Safety Communications and Autonomous Safety Systems .....</b>	<b>8</b>
	4.1 Crash Imminent Scenarios for Safety Applications .....	9
	4.2 Reported Shortcomings and Suggested Root Causes of Autonomous Safety Systems in Addressing Crash imminent Scenarios .....	10
	4.3 Shortcomings and Root Causes Addressed with DSRC-Based Vehicle Safety Communications.....	10
	4.4 Crash Imminent Scenarios Addressed Specifically with DSRC-Based Vehicle Safety Communications .....	10
<b>5</b>	<b>Task 4 Summary: Vehicle Safety Communication System Definition... </b>	<b>11</b>
	5.1 Identification of Safety Applications and Supporting Framework .....	11
	5.2 Safety System Structure .....	13
	5.3 Methods to Address Root Causes of Autonomous Safety System Shortcomings .....	16
<b>6</b>	<b>Task 5 Summary: DSRC+Positioning Only Safety System Structure Development .....</b>	<b>16</b>
	6.1 System Concepts of Operation, Requirements, and Minimum Performance Specifications .....	17
	6.2 Communication Architecture, Standardized Messages, and Protocols .....	17
	6.2.1 Message Composition .....	18
	6.2.2 Security .....	18
	6.2.3 Channel 172 Usage .....	19
	6.2.4 Standards Validation .....	19
	6.2.5 International Trends .....	20
	6.3 Relative Vehicle Positioning Development .....	20
	6.4 Integration of Forward-Looking Camera for Vehicle Positioning Aiding .....	22

<b>7</b>	<b>Task 7 Summary: Vehicle Safety Communication System Test Bed ....</b>	<b>22</b>
7.1	VSC-A System Test Bed – Design.....	23
7.2	VSC-A System Test Bed – Development .....	24
7.3	VSC-A System Test Bed – In-Vehicle System Integration .....	25
<b>8</b>	<b>Task 10 Summary: Benefits Analysis Support.....</b>	<b>28</b>
<b>9</b>	<b>Task 11 Summary: Project Administration.....</b>	<b>28</b>
<b>10</b>	<b>Tasks 6, 8, and 9 Summary – No Major Activities.....</b>	<b>28</b>
<b>11</b>	<b>References .....</b>	<b>29</b>
<b>12</b>	<b>Acronyms .....</b>	<b>30</b>

## List of Figures

Figure 1 – VSC-A Research Activities and Timeline.....	4
Figure 2 - VSC-A Level I Preliminary System Block Diagram .....	15
Figure 3 - VSC-A Level II Preliminary System Block Diagram.....	16
Figure 4 – Candidate Relative Positioning Module Implementation.....	21
Figure 5 - VSC-A Preliminary OBE Software Architecture .....	25
Figure 6 – WSU Single Radio Hardware and Interface Architecture.....	26
Figure 7 – VSC-A Preliminary WSU HW Interfaces.....	27

## List of Tables

Table 1 – VSC-A Task Breakdown .....	2
Table 2 – VSC-A Task to Working Group Distribution.....	3
Table 3 – VSC-A Selected Crash Imminent Scenarios .....	9
Table 4 – Crash Imminent Scenario to VSC-A Application Mapping .....	13

## **1 Introduction**

The United States Department of Transportation (USDOT) has conducted extensive research on the effectiveness of vehicle-based collision countermeasures for rear-end, road departure and lane change crashes. Field Operational Tests (FOT) of rear-end and road departure collision warning systems have shown measurable benefits in reduction of crashes. However, the systems have inherent shortcomings that reduce their effectiveness and limit driver acceptance. These shortcomings include misidentification of stopped cars and in-path obstacles for rear-end collision warning systems, as well as map errors and misidentified lane markings for road departure crash warning systems. Vehicle-to-vehicle (V2V) wireless communications and vehicle positioning may enable improved safety system effectiveness by complementing or, in some instances, providing alternative approaches to autonomous safety equipment.

The USDOT and the Vehicle Safety Communications 2 Consortium (VSC 2 Consortium – Mercedes-Benz (MB), Ford, General Motors (GM), Honda & Toyota) have initiated a 3-year collaborative effort in the area of wireless-based safety applications under the Vehicle Safety Communications – Applications (VSC-A) project. The goal of VSC-A is to develop and test communications-based vehicle safety systems to determine if Dedicated Short Range Communications (DSRC) at 5.9 GHz, in combination with vehicle positioning can improve upon autonomous vehicle-based safety systems and/or enable new communications-based safety applications.

To address the goal of the VSC-A program as stated above, the program has the following list of objectives:

- Assess how previously identified crash imminent safety scenarios in autonomous systems could be addressed and improved by DSRC+Positioning systems
- Define set of DSRC+Positioning based vehicle safety applications and application specifications including minimum system performance requirements
- In coordination with NHTSA and VOLPE, develop a well understood and agreed upon benefits versus market penetration analysis and potential deployment models for a selected set of communication-based vehicle safety systems
- Develop scalable, common vehicle safety communication architecture, protocols and messaging framework (interfaces) necessary to achieve interoperability and cohesiveness among different vehicle manufacturers. Standardize this messaging framework and the communication protocols (including message sets) to facilitate future deployment.
- Develop accurate and affordable vehicle positioning technology needed, in conjunction with the 5.9 GHz DSRC, to support most of the safety applications with high potential benefits
- Develop and verify a set of objective test procedures for the vehicle safety communications applications

## 2 Task 1 Summary: Program Management

The Vehicle Safety Communications – Applications (VSC-A) project officially started on December 7, 2006 with the formal kickoff between the VSC-A team and the USDOT held in Washington, D.C. on February 6, 2007. The main agenda of the kickoff meeting was to cover contractual issues governing the project and to provide a project overview to the members of the USDOT team, including members from Noblis and Volpe.

To help achieve the objectives of the project as stated in Section 1, the VSC-A project activities were divided into eleven tasks, and where appropriate sub-tasks, and are listed in Table 1. The tasks define a structure for the work to be done in the program.

**Table 1 – VSC-A Task Breakdown**

Task #	Task Title	Sub-Task(s)
1	Program Management	NA
2	Coordination with Standards Development Activities and Other USDOT Programs	NA
3	Vehicle Safety Communications and Autonomous Safety Systems	3.1: Identify the set of generic shortcomings that affects rapid deployment of autonomous safety systems 3.2: Identify root causes behind shortcomings 3.3: Identify subset of shortcoming and root causes that can be addressed with the addition of DSRC+Positioning 3.4: Identify and analyze new crash imminent scenarios addressed by DSRC+Positioning safety system and analyze advantages of the system
4	Vehicle Safety Communication System Definition	4.1: Identify DSRC+Positioning methods to address root causes of autonomous safety system shortcomings 4.2: Identify safety features of vehicle safety communication system 4.3: Define safety system structures
5	DSRC+Positioning Only Safety System Structure Development	5.1: System concepts of operation, requirements and minimum performance specifications

		<p>5.2: VSC system architecture, communication architecture, standardized messages, and protocols</p> <p>5.3: Relative vehicle positioning development (for V-V safety applications)</p> <p>5.4: Integration of forward looking camera for vehicle positioning aiding</p>
6	DSRC+Positioning and Autonomous Sensing Safety System Analysis	NA
7	Vehicle Safety Communication System Test Bed	NA
8	Objective Test Procedures	NA
9	System Testing and Objective Test Procedure Validation	NA
10	Benefits Analysis Support	NA
11	Program Administration	NA

Due to a number of the tasks listed in Table 1 which contain overlapping content and timeframes, in addition to the size of some of the tasks, working groups (WG) were formed to address the work to be performed under the tasks. Whole tasks or portions of individual/multiple tasks were assigned to the individual working groups. The VSC-A technical team finalized the work group structure for the project consisting of nine (9) WGs to perform the various activities under the project. Table 2 lists these WGs and the corresponding task /sub-tasks that they comprise.

**Table 2 – VSC-A Task to Working Group Distribution**

WG #	WG Title	Corresponding Task
-	Program Lead/Project Management	Tasks 1 & 10
1	Standards Development	Task 2
2	System Development	Tasks 3, 4, 5.1, 6 & 7 (design)
3	Message Composition	Task 5.2
4	Security	Task 5.2
5	Communications Protocol	Task 5.2
6	Positioning	Tasks 5.3 & 5.4
7	Test Bed Integration	Task 7 (integration)
8	Objective Test Procedures	Task 8
9	System Testing	Task 9

While the activities of the tasks have been allocated to work groups, for the Project as a whole, the tasks have been grouped into four VSC-A research activities. Figure 1 shows

the planned roadmap of these research activities along with the corresponding tasks, interactions, and timeline.

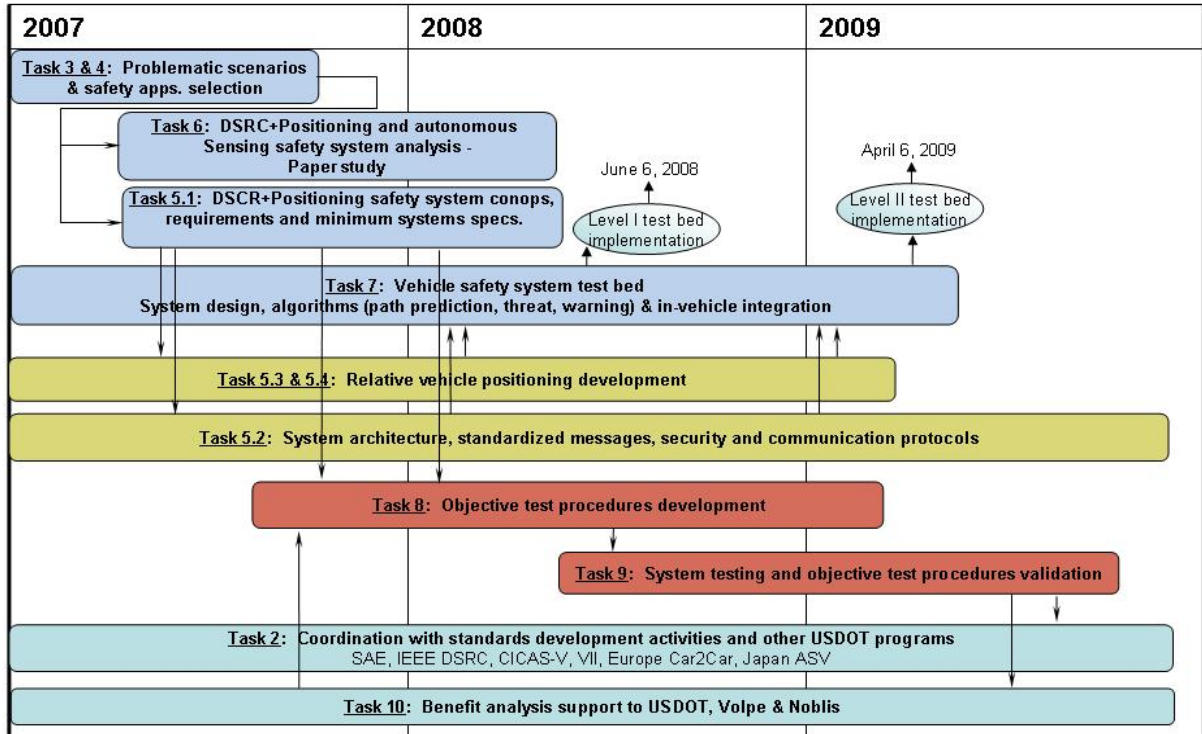

**Figure 1 – VSC-A Research Activities and Timeline**

The four major activity areas highlighted in the chart above are:

1. System Definition, Design, and Development, including:
  - a. Crash scenario selection
  - b. Safety application selection
  - c. System concept of operation, requirement, and minimum specification
  - d. System test bed development
  - e. In-vehicle integration
2. Communications and Relative Vehicle Positioning development, which can be considered required technology enablers for safety application effectiveness
3. System Test development, Test execution, and Validation
4. Coordination and Support with other programs/organizations

With the project task and working group structure in place throughout the year, the Principal Investigator (PI) managed all the technical activities between the five OEMs under the VSC-A project. In addition to overseeing the Technical Management Team (TMT) members' weekly meetings, as well as face-to-face workshops, to ensure they were organized so that adequate work progress was being achieved, the major activities undertaken as part of Task 1 included:

- Preparation and execution of the first four VSC-A Progress Briefings for the USDOT along with the OEM management team
- Submission of the following VSC-A project deliverables to the USDOT:
  - The "VSC-A Research Management Plan"
  - The "VSC-A 1st Quarterly Status Report"
  - The "VSC-A 2nd Quarterly Status Report"
  - The "VSC-A 3rd Quarterly Status Report"
  - The "Task 2: Interim Report I"
  - The "Task 3: Interim Report"
  - The "Task 5: Interim Report I"
- Finalizing the set of crash scenarios and corresponding safety applications to be studied under the VSC-A
- Definition of the initial version of the DSRC+Positioning-only vehicle communication safety system test bed structure
- Development, refinement and finalization of concepts, requirements, and designs for the safety applications to be developed under the project
- Oversight and finalization of the Request For Quotation (RFQ) process under the subtask 5.2 – Security
- Oversight and finalization of the Request For Quotation (RFQ) process under the subtask 5.3 - Relative Vehicle Positioning
- Oversight and finalization of the Request For Quotation (RFQ) process under Task 7 to develop, implement, and verify a VSC-A On-Board Equipment (OBE) Test Bed software implementation
- Kick-off of the Task 7 VSC-A system test bed implementation on October 18-19, 2007
- Demonstration of V2V EEBL OEM interoperability for USDOT officials in November 2007

### **3 Task 2 Summary: Coordination with Standards Development Activities and Other USDOT Programs**

All the technical work conducted as part of the VSC-A project will be carried out under Task 3 through Task 10 of this work plan. The activities conducted under those tasks will

result in findings that are important to the VSC-A project and may need to be standardized, coordinated and/or communicated with other organizations, programs, and standardization activities. Task 2 will use findings from Task 3 through Task 10 of this project to prepare material to be shared with standards development activities and other relevant programs to ensure that the VSC-A system can be successfully deployed in the future, to minimize overlap and to ensure effective coordination with other programs.

The activities under Task 2 of this project will be done in cooperation with similar activities under the CICAS-V project to ensure that the coordination with standards development activities with other USDOT and international programs is carried out with efficient use of resources supporting both programs.

An important goal of the VSC-A project is the standardization of the message sets, message composition approach, and communication protocols for 5.9 GHz DSRC-based vehicle safety. In order to achieve this goal, the VSC-A standards WG developed a standards support plan in February 2007. This plan outlines the current standards landscape and provides a guideline by which the VSC-A standards WG will coordinate their interactions between the other Task activities/results and the identified relevant Standard Development Organizations (SDOs) activities. The VSC-A team completed the review and update of the standards support plan document with the final version submitted during the month of April 2007 to the USDOT.

As part of the short-term standards support activities highlighted in the plan, the VSC-A team has substantially increased OEM participation under the Society of Automotive Engineers (SAE) DSRC Technical Committee (TC) as well as the 802.11p and P1609 standardization processes. The VSC-A team will continue active participation to guide the developing standard based on the output of the work being performed under Task 5 of the VSC-A project.

### **3.1 IEEE 1609.x:**

The IEEE 1609 Family of Standards for Wireless Access in Vehicular Environments (WAVE) defines the architecture, communications model, management structure, security mechanisms, and physical access for wireless communications in the vehicular environment.

The VSC-A team participated in the 1609 Working Group proceedings in the second quarter of 2007. As a result of the standards validation work under Task 5.2 of the VSC-A project, the team is able to offer an OEM technical perspective into these proceedings. With the 1609 document up for a Version 2 revision, the VSC-A Standards WG is monitoring the revision process and is participating in these activities.

### **3.2 IEEE 802.11p:**

Wireless Access in Vehicular Environments is a mode of operations for use by 802.11 compliant devices that enable low latency communication exchanges. The 802.11p document defines the Physical (PHY) and Medium Access Control (MAC) level amendments to the overall IEEE 802.11 standards so as to allow for efficient vehicular communications. This document is currently an unapproved draft of a proposed IEEE Standard.

Since the conception of the VSC-A project, the VSC-A Standards working group has been an active participant in the proceedings of the 802.11 Task Group (TGp). The VSC-A group has carefully studied the current draft version of 802.11p and have offered several technical comments in an effort to improve the document.

One of the main activities taking place under 802.11p is obtaining letter ballot (LB) approval. To date, the 802.11p document has failed three letter ballots (LB) narrowly failing the third letter ballot attaining roughly 74% of the 75% required for approval. It is the belief of the VSC-A Standards working group that despite failing the latest letter ballot, the IEEE 802.11p standard is on the right track to become more technically mature and practically feasible.

Since the last letter ballot, the group has been active in the comment resolution process. Through the comment resolution process, the VSC-A group made formal submissions at the 802.11 meetings that have resulted in revised versions of clause 3 and 5.2.2a in the document. The VSC-A group is currently working on a rewrite of clause 11 of the TGp document. This document will be presented and put to vote at the next 802.11 meeting in January of 2008. It is expected that this document will resolve a large number of comments associated with this clause.

The document is moving closer to being put into the next letter ballot. The VSC-A group hopes to work closely with members from TGp to have the 802.11p ready for letter ballot by March 2008.

Other notable VSC-A Standards group 802.11p activities include:

- The VSC-A group made an informational presentation outlining the results of the cross channel interference tests conducted by Toyota ITC, Toyota Technical Center and General Motors. This presentation was well received by the task group.
- A presentation was held informing TGp about potential issues with the existing Basic Service Set Identifier (BSSID) mechanism. To mitigate this problem, two solutions were proposed. However, a consensus could not be reached on either of the proposed solutions. The standards working group plans to study this matter more in detail in an effort to better understand the problem and provide an effective solution. Solving the potential issues with the existing BSSID mechanism will be one of the high priority topics in the early part of 2008.

### **3.3 SAE DSRC J2735:**

The SAE J2735 Standard specifies initial representative standard message sets, data frames, and data elements that allow interoperability at the application layer without the need to standardize applications. This approach supports innovation and product differentiation through the use of proprietary applications, while maintaining interoperability by providing standard message sets that can be universally generated and recognized by these proprietary applications.

The message sets specified in the SAE J2735 Standard depend upon the DSRC protocol stack to deliver the messages from applications. In particular, the lower layer protocols

are addressed by IEEE P802.11p, and the upper layer protocols are covered in the IEEE P1609 series of standards.

The VSC-A team has been actively involved in the SAE DSRC J2735 standard development since the beginning of this year with active participation in the nine monthly joint SAE J2735 Technical Committee (TC)/Vehicle Safety Subcommittee meetings. The VSC-A team introduced the VSC-A project overview to the DSRC standard committee and it was well received. The VSC-A team has established a highly-credible position in the SAE DSRC J2735 with at least three VSC-A team members regularly attending the monthly meetings. One of our VSC-A members also served as Vice Chair in the Vehicle Safety Subcommittee during 2007 and will serve as the Chair of the Vehicle Safety Subcommittee and the Secretary of the Technical Committee from 2008 to 2010.

The VSC-A team reviewed the current published version of the standard and provided several valuable technical comments in an effort to improve the document. The VSC-A team proposed the definition of two new data elements –VehicleMotionTrail (breadcrumbs) and TriggerEvent and also made some proposals on the usage of tags and correction on missing or incorrect message IDs. These proposals and the related corrections are now included in the latest J2735 internal revision.

The VSC-A team advised against a proposal to replace the single version of the Basic Safety Message (BSM) format with two versions, long and short, which would be interleaved. The drawbacks of having a long Basic Safety Message and a short one, such as the potential negative impact on the system complexity with no significant gain on reducing data flow due to the large overhead due to the security protocol, were explained to the SAE J2735 TC which agreed with the VSC-A team's advisement.

The J2735 Standard document is moving closer to being ready for the next revision ballot. Also the plan of evolving the document closer to being applicable to the real-world applications is being established. The VSC-A group hopes to work closely with the SAE DSRC Committee members in 2008 to facilitate the balloting of the next revision and to improve the standard to be ready for the real-world application trial testing.

## **4 Task 3 Summary: Vehicle Safety Communications and Autonomous Safety Systems**

A primary objective of the VSC-A project is to determine if vehicle safety applications that utilize DSRC-based vehicle safety communications can enhance the overall safety system performance. A potential advantage of DSRC-based vehicle safety communications is that cooperative communications may provide significant additional information about the driving situation that goes well beyond the capabilities of object sensing used in autonomous safety systems. The objective of Task 3 of the VSC-A project is to determine if the addition of DSRC-based vehicle safety communications might help overcome some of the limitations of autonomous systems.

This task was concluded during the 4<sup>th</sup> Quarter of 2007 with the submission of the final revised document of the "Task 3: Interim Report," incorporating the comments from the USDOT. The following sections provide a summary of the activities that took place under this task.

## 4.1 Crash Imminent Scenarios for Safety Applications

The USDOT provided the "VSC-A Crash Test Scenarios" document 0 to serve as a starting point for the analysis under Task 3 and also as a reference for the selection of the final set of safety applications to be studied under the VSC-A project. The USDOT evaluated pre-crash scenarios in order to provide potential crash imminent safety scenarios for study under the VSC-A project. The document included crash imminent safety scenarios based on the following USDOT rankings as documented in 0:

- Crash rankings by frequency
- Crash rankings by cost
- Crash rankings by functional years lost
- Composite crash rankings

The set of crash scenarios was based on the 2004 General Estimated System (GES) crash database. The first three rankings were self explanatory. The composite crash rankings assembled the rankings into a composite ranking and sorted the crash scenarios based on the composite ranking. It also indicated which systems (autonomous, VSC-A, or both) address or could address the different crash scenarios presented.

From the composite ranking list of crash scenarios, the top five (5) scenarios for each crash frequency, crash cost, and functional years lost that could be addressed by VSC-A were selected. This was done in order to focus on the most frequent crashes, while keeping the program scope to a manageable level. Table 3 contains the final set of crash imminent scenarios, as agreed between the VSC-A team and the USDOT, to be addressed under the VSC-A project.

**Table 3 – VSC-A Selected Crash Imminent Scenarios**

	<b>Crash Imminent Scenario</b>	<b>High Freq</b>	<b>High Cost</b>	<b>High Years</b>
1	Lead Vehicle Stopped	✓	✓	✓
2	Control Loss without Prior Vehicle Action	✓	✓	✓
3	Vehicle(s) Turning at Non-Signalized Junctions	✓	✓	
4	Straight Crossing Paths at Non-Signalized Junctions			✓
5	Lead Vehicle Decelerating	✓	✓	
6	Vehicle(s) Not Making a Maneuver – Opposite Direction			✓
7	Vehicle(s) Changing Lanes – Same Direction	✓		
8	LTAP/OD at Non-Signalized Junctions			

✓ Denotes Top Five Ranking

NOTE: Table 3 only shows four of the top five ranking crash scenarios for high cost and high functional years lost. This is due to the #2 ranking for these categories being 'Road Edge Departure without Prior Vehicle Maneuver' which was not deemed as a viable scenario to be addressed under the VSC-A program.

## **4.2 Reported Shortcomings and Suggested Root Causes of Autonomous Safety Systems in Addressing Crash imminent Scenarios**

Of the crash scenarios in Table 3, only the ‘Lead Vehicle Stopped’, ‘Lead Vehicle Decelerating’, and ‘Vehicle(s) Changing Lanes – Same Direction’ scenarios are addressed by existing autonomous safety systems. The various reported shortcomings observed in FOTs with autonomous safety systems in addressing these scenarios and the suggested root causes behind those shortcomings were listed. Reports from the ACAS FOT [1] and RDCW FOT 0 were used to identify some of these shortcomings and their corresponding possible root causes. The ACAS system focused on rear-end crashes, and the RDCW system focused on road-departure crashes due to lateral drift and control loss.

Note that the ACAS and RDCW FOT results did not provide the complete information required for this exercise, thus, several generic possible shortcomings were identified based on the expert engineering judgments of the VSC-A Team. These judgments were based on an understanding of the scenario description and internal experience working with autonomous safety systems.

The remaining crash scenarios in Table 3 are not addressed by existing autonomous systems. Hence, the specific shortcomings and root causes of autonomous safety systems in addressing those scenarios are not known. The VSC-A system may have the unique potential to show benefits in addressing those scenarios.

## **4.3 Shortcomings and Root Causes Addressed with DSRC-Based Vehicle Safety Communications**

A potential advantage of DSRC-based vehicle safety communications is that cooperative communications may provide significant additional information about the driving situation that goes well beyond the capabilities of object sensing used in autonomous safety systems. Based on current knowledge and engineering experience with vehicle-to-vehicle safety communications, the reported shortcomings and possible root causes that may be addressed with DSRC-based vehicle-to-vehicle safety communications were identified. It should be noted that this exercise was aimed at the expected improvement of DSRC-based V2V communications safety systems over autonomous only ones, since it will not be known until later in the VSC-A project if DSRC contributes to the resolution of the reported shortcomings and possible root causes identified.

## **4.4 Crash Imminent Scenarios Addressed Specifically with DSRC-Based Vehicle Safety Communications**

For the scenarios addressed by existing autonomous safety systems, the principal other vehicle needs to be directly within the host vehicle sensor line-of-sight so that the scenarios can be addressed by existing autonomous systems. For these scenarios, particular situations exist where no sensor direct line of sight exists between the vehicles involved in those scenarios. A number of these situations were identified where it appears that the VSC-A DSRC-based vehicle safety communications system has the potential to address these particular situations.

Additionally, for the scenarios in Table 3 that are not addressed by existing autonomous systems, a number of situations for each of those scenarios where DSRC-based vehicle safety communications may provide unique solutions were identified and discussed.

## 5 Task 4 Summary: Vehicle Safety Communication System Definition

The purpose of this task is to define the full set of safety features for vehicle safety communications based on DSRC+Positioning only or a hybrid version, comprising of DSRC+Positioning and autonomous sensing (e.g. radar, vision, etc.) systems, for subsequent work under this project. The VSC-A team worked with NHTSA to jointly define and finalize the list of safety features of the vehicle safety communications system and technology enablers to be studied in this project.

The defined safety application set was used to develop a preliminary safety system structure. This structure includes required system framework modules and the deployment of and interaction between the safety applications and framework modules.

The complete list of safety application and system framework modules and system structure were provided as inputs to sub-task 5.1 to serve as the basis for the system concepts of operation and requirements definition efforts to take place under that sub-task.

### 5.1 Identification of Safety Applications and Supporting Framework

The VSC-A Team and USDOT analyzed the crash imminent scenarios in Table 3 and reviewed the proposed safety applications from the VSC-A Technical Proposal to assess whether modification of the initial list of applications was required. This analysis resulted in the selection of the following safety applications for the VSC-A system test bed:

- Emergency Electronic Brake Light (EEBL)

*The EEBL application enables a host vehicle to broadcast a self-generated emergency brake event to surrounding remote vehicles. Upon receiving such event information, the remote vehicle determines the relevance of the event and provides a warning to the driver if appropriate. This application is particularly useful when the driver's line of sight is obstructed by other vehicles or bad weather conditions (e.g. fog, heavy rain).*

- Forward Collision Warning (FCW)

*The FCW application is intended to warn the driver of the host vehicle in case of an impending rear-end collision with a remote vehicle ahead in traffic in the same lane and direction of travel. FCW is intended to help drivers in avoiding or mitigating rear-end vehicle collisions in the forward path of travel.*

- Intersection Movement Assist (IMA)

*The IMA application is intended to warn the driver of a host vehicle when it is not safe to enter an intersection due to high collision probability with other remote vehicles. Initially, IMA is intended to help drivers avoid or mitigate vehicle collisions at stop sign controlled and uncontrolled intersections.*

- Blind Spot Warning + Lane Change Warning (BSW + LCW)

*The BSW+LCW application is intended to warn the driver of the host vehicle during a lane change attempt if the blind spot zone into which the host vehicle intends to switch is, or will soon be, occupied by another vehicle traveling in the same direction. Moreover, the application provides advisory information that is intended to inform the driver of the host vehicle that a vehicle in an adjacent lane is positioned in a blind spot zone of the host vehicle when a lane change is not being attempted.*

- Do Not Pass Warning (DNPW)

*The DNPW application is intended to warn the driver of the host vehicle during a passing maneuver attempt when a slower moving vehicle, ahead and in the same lane, cannot be safely passed using a passing zone which is occupied by vehicles with the opposite direction of travel. In addition, the application provides advisory information that is intended to inform the driver of the host vehicle that the passing zone is occupied when a passing maneuver is not being attempted.*

- Control Loss Warning (CLW)

*The CLW application enables a host vehicle to broadcast a self-generated control loss event to surrounding remote vehicles. Upon receiving such event information, the remote vehicle determines the relevance of the event and provides a warning to the driver, if appropriate.*

Note: The set of six safety applications was selected, in part, due to these applications:

- Allowing for the extension of the work carried out in the VSC and EEBL projects
- In combination, addressing the top five (5) scenarios for each crash frequency, crash cost, and functional years lost
- In combination, allowing the program to focus on the most frequent crashes, while keeping the program scope to a manageable level
- Each being capable of being addressed by V-V communications plus positioning technology

In addition to the list above, which defines the safety applications to be incorporated into the system test bed, the Pre-Crash Sensing and Collision Mitigation (PCS&CM) safety application will be studied under the VSC-A project in order to capture its potentially unique messaging requirements. However, no provisions were made under the VSC-A Technical Proposal or have been made to incorporate PCS&CM as part of the test bed.

Table 4 below illustrates the mapping between the crash imminent scenarios identified in Table 3 and the list of safety applications to be developed and built under this task and Tasks 5, 6, and 7.

**Table 4 – Crash Imminent Scenario to VSC-A Application Mapping**

	<b>Crash Scenario</b>	<b>EEBL</b>	<b>FCW</b>	<b>BSW</b>	<b>LCW</b>	<b>DNPW</b>	<b>IMA</b>	<b>CLW</b>
1	Lead Vehicle Stopped		✓					
2	Control Loss without Prior Vehicle Action							✓
3	Vehicle(s) Turning at Non-Signalized Junctions						✓	
4	Straight Crossing Paths at Non-Signalized Junctions						✓	
5	Lead Vehicle Decelerating	✓	✓					
6	Vehicle(s) Not Making a Maneuver – Opposite Direction					✓		
7	Vehicle(s) Changing Lanes – Same Direction			✓	✓			
8	LTAP/OD at Non-Signalized Junctions						✓	

The complete list of safety application modules was provided as an input to sub-task 5.1 to serve as the basis for the system concepts of operation and requirements definition efforts for the safety applications under that sub-task.

## 5.2 Safety System Structure

In order to support the safety applications listed in section 5.1, the following major subsystems with their corresponding system framework modules were identified to be developed under VSC-A:

1. The DSRC Communications Subsystem, to be studied under subtask 5.2, consists of the following:
  - The Wireless Message Handler (WMH)
  - The Security Module
  - The DSRC radio
2. The Vehicle Positioning Subsystem to be studied under subtasks 5.3 and 5.4 consists of the following:
  - VSC-A GPS module
  - Forward Looking Camera Subsystem
3. The V-V Supporting Subsystem consists of the following:
  - The Sensor Data Handler (SDH)

- The Vehicle Path History Module (PH)
  - The Host Vehicle Path Prediction Module (HVPP)
  - The Target Classification Module (TC)
  - The Safety Applications Module
  - The Threat Arbitration Module (TA)
  - The Engineering Driver Vehicle Interface Notifier (DVI)
4. The Interface Subsystem consists of:
- The Vehicle CAN to OBE Interface (CAN/OBE interface module)
  - The Data Logger
  - The Engineering GUI

In an attempt to make the most effective use of the three-year project timeline, and due to the fact that no prototyping of the safety applications was planned to take place prior to their implementation, as well as to account for the lead time required for the definition and design of portions of the communications and positioning work, two successive levels of development, referred to as 'Level I' and 'Level II' were defined to be undertaken for this program. The preliminary system block diagrams in Figure 2 and Figure 3 highlight the major subsystems being developed under VSC-A.

### **Level I Development**

The Level I development involves the initial implementation of all the safety and system framework modules. For the GPS solution, Level I will initially use a GPS module that supports an absolute positioning solution and then transition to a module that supports an initial relative positioning solution with the possibility of using both solutions simultaneously. Due to this multi-stage GPS development effort, at times during the program, Level I will be referred to as the Level Ia (absolute positioning) and Level Ib (relative positioning) sub-levels. In conjunction with the multi-stage GPS development, it should be noted that Level I is being defined to allow trade off studies to be conducted in order to select the potential approach, or application implementation, for subsequent Level II final integration. This is being accomplished by:

1. Basing the Level I software architecture on a flexible/configurable, development friendly system implementation
2. Defining/implementing multiple designs and alternatives for some of the applications and supporting framework modules

Taking the combined list of safety applications and system framework modules, a preliminary VSC-A Level I System Block Diagram was developed, see Figure 2. This System Block Diagram provides the breakdown of the OBE safety, framework, and other modules to be developed during the Level I implementation phase, the planned interaction between these modules, and the planned internal and external deployment of these modules as part of a comprehensive DSRC+Positioning-based safety system.

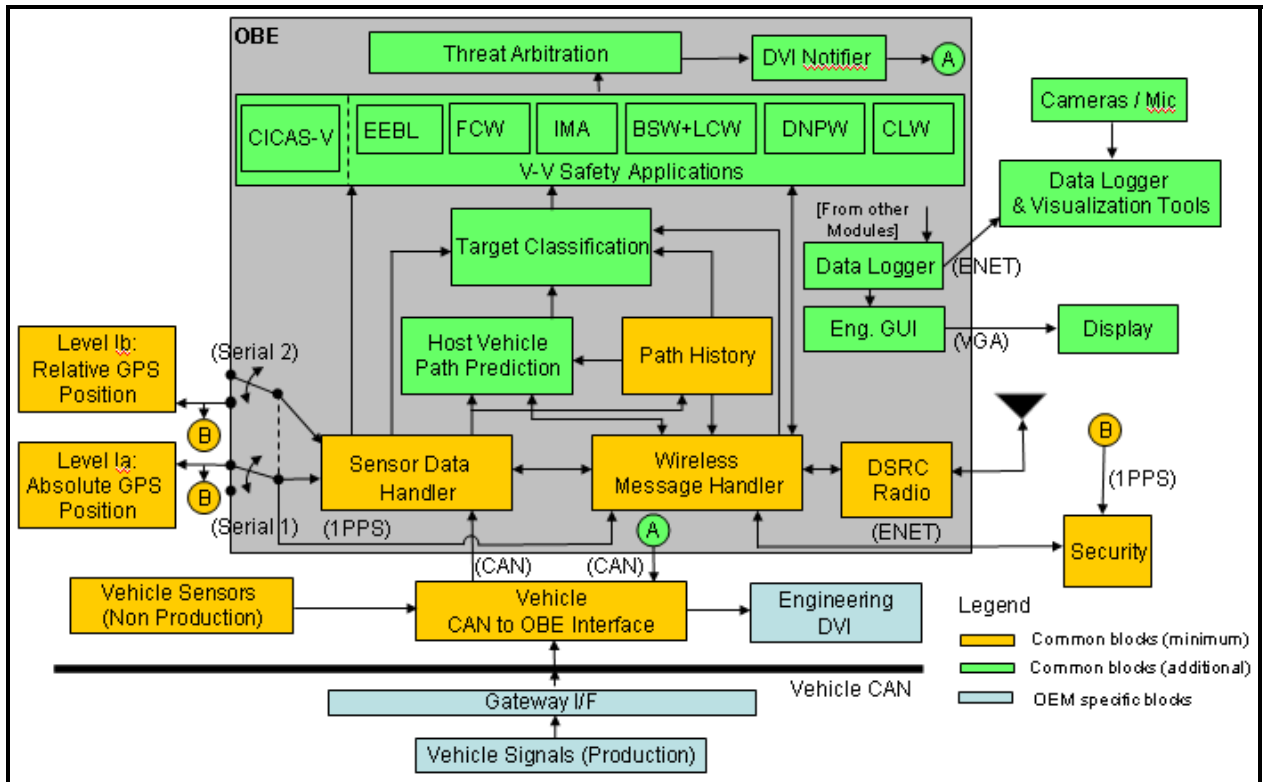

**Figure 2 - VSC-A Level I Preliminary System Block Diagram**

### Level II Development

The Level II development will be based on the Level I development and will involve making enhancements to the elements developed during Level I. These enhancements will be based on the results of the testing and analysis performed on the Level I implementation as well as additional knowledge gained during this testing, analysis, and other activities.

In addition to making enhancements to the Level I implementation, the Level II work will mainly involve working on the following additions, changes, and enhancements to the Level I Positioning and Communications development:

- Forward looking camera for positioning aiding
- Integration of the security module, via a mini-PCI card solution (developed by a third party), into the OBE
- Implementation of a dual radio configuration on the same OBE for multi-channel usage studies
- Implementation of real-time, per packet, channel switching (either instead of, or in combination with the multi-radio solution)
- Implementation of power / rate control protocols

The Level II Final system version is to be used for the formal testing planned under Task 9 "System Testing."

The following VSC-A Level II System Block Diagram, Figure 3, provides the current preliminary planned breakdown of OBE modules to be developed during the Level II implementation phase, the planned interaction between these modules, and the planned internal and external deployment of these modules.

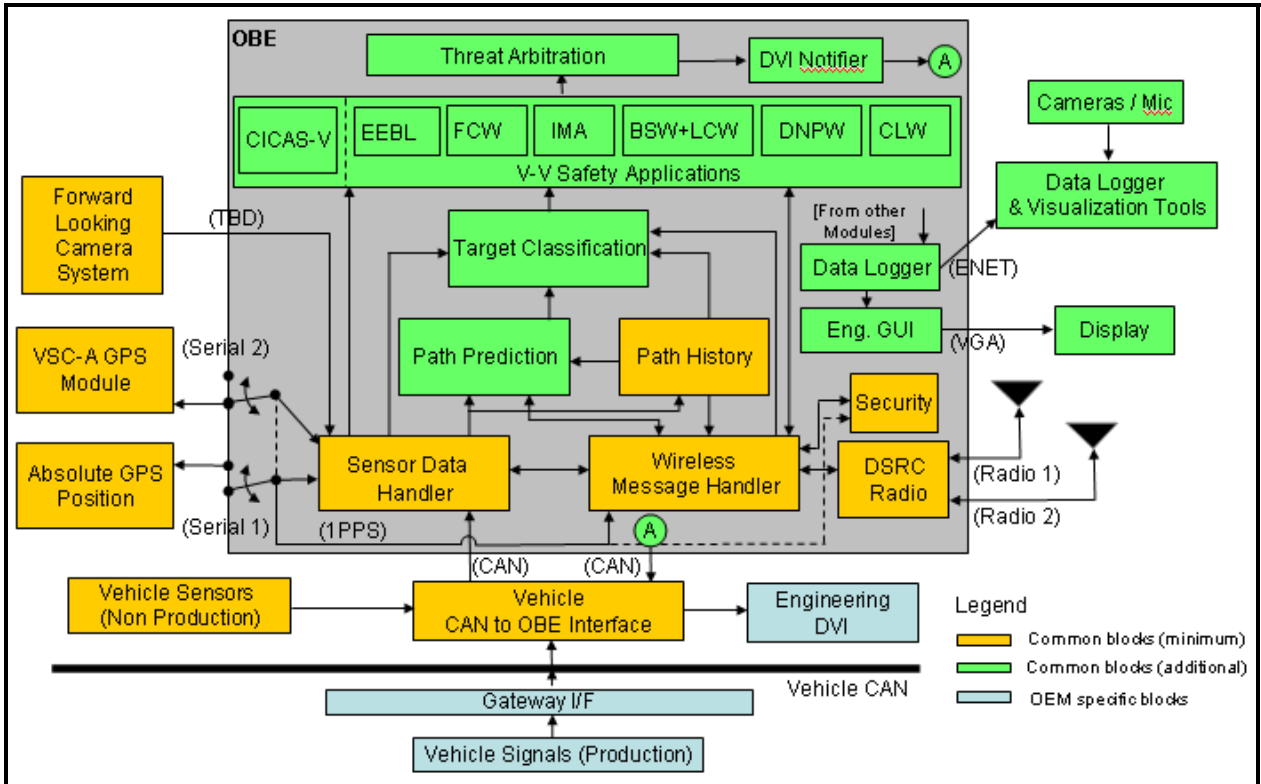

Figure 3 - VSC-A Level II Preliminary System Block Diagram

The complete list of system framework and interface modules was provided as an input to sub-task 5.1 to serve as the basis for the system concepts of operation and requirements definition efforts for these modules under that sub-task.

### 5.3 Methods to Address Root Causes of Autonomous Safety System Shortcomings

The VSC-A Team, given the Task 3 analysis, has initiated identification of DSRC+Positioning methods that may address root causes of autonomous safety system shortcomings. The results will be documented as part of a Task 4 Interim Report.

## 6 Task 5 Summary: DSRC+Positioning Only Safety System Structure Development

The objective of Task 5 is to define the most efficient system development method to achieve a DSRC+Positioning-based “single vehicle safety communication system” by addressing the following:

1. System concepts of operation, requirements, and minimum performance specifications
2. An interoperable, scalable Vehicle Safety Communications (VSC) architecture that can support a large number of vehicles
3. Affordable and reliable vehicle relative positioning needed for VSC system features
4. The benefits of exchanging vision-based sensor information between vehicles, over DSRC, for improving the overall performance of the VSC-A applications.

The primary input to Task 5 was the set of vehicle safety applications and supporting system framework modules identified through the work of Tasks 3 and 4. By taking this list of applications and addressing items one through four listed above, a preliminary set of concepts of operation and requirements specification documents was developed. These documents were the basis for the work taking place in Task 7 – “Vehicle Safety Communication System Test Bed.”

## **6.1 System Concepts of Operation, Requirements, and Minimum Performance Specifications**

Under sub-task 5.1, the system concepts of operation and requirements for the proposed VSC-A system as detailed in sections 5.1 and 5.2 were developed by sub-teams within the VSC-A team. The sub-teams used a common template to facilitate the future integration of all the safety applications and subsystems into a unique system design. This template included the following:

- A definition/concept description
- User requirements for the safety applications
- Functional requirements
- A state transition diagram
- A functional context diagram
- A signal interface description (I/O)

Multiple face-to-face workshops were held to review the sets of requirements. Comments and suggestions were collected and the draft requirement documents were updated by the team. This set of documents formed the basis for the VSC-A test bed system *design phase* under Task 7 and will be the foundation of the VSC-A system to be implemented and tested in Tasks 7, 8, and 9.

## **6.2 Communication Architecture, Standardized Messages, and Protocols**

The overall goal of Task 5.2 is to develop a scalable and interoperable vehicle safety communication systems architecture, including channel considerations, protocols, and security. During the first year of the VSC-A project, notable progress was made in message composition, security, multi-channel operation, and standards validation.

Task 5.2 is organized into seven subtasks of which several were active in 2007. The following summary sections are organized by subtask.

### **6.2.1 Message Composition**

Message Composition has two areas of focus: 1) the content and structure of over-the-air messages and 2) the Wireless Message Handler function.

#### **Over-the-air Message Content and Structure**

The VSC-A team held a number of workshops devoted to message content and structure and developed a consensus on several key points.

It was agreed that messages should conform, as much as possible, to the emerging SAE J2735 DSRC Message Set Dictionary standard. Thus, to work towards conformity, the VSC-A team did and must continue to work with the SAE J2735 standards committee to see that the SAE J2735 standard meets the needs of the VSC-A project. See section 6.2.4 for a discussion on the standards work performed under this task.

#### **Wireless Message Handler (WMH)**

The WMH function plays a key role in the communications system architecture. It provides message communication services to the safety applications, insulating them from the details of the over-the-air communication technology. The WMH composes outgoing messages and parses incoming messages. The requirements definition and high level design principles for the WMH were developed and provided as an input to the Task 7 activities. It was agreed that candidate WMH designs should be compared, among other things, on the basis of bandwidth efficiency, implementation and computational complexity, and message latency.

### **6.2.2 Security**

The Security subtask is focused primarily on message authentication in a context that preserves sender privacy and controls bandwidth overhead, processing requirements, and latency.

Three face-to-face security workshops were held during the year. The first served as an internal seminar and helped in the development of an RFQ for an external security consultant. The second constituted a kick-off meeting for the team and the consultant to form a work plan. The third advanced the work of the team, particularly with regard to the threat model and simulation studies.

Working with the consultant, a threat model document was developed, which considers privacy vs. revocation, certificate distribution and revocation, and computational and bandwidth requirements. Threats to privacy were identified as a major priority.

Several candidate security protocols for broadcast authentication and privacy protection were also developed. These were subjected to a preliminary evaluation, which will continue in the second year of the project.

Finally, work also began on the Level 1 test-bed implementation, including the definition of over-the-air security message formats and the interface between the OBE and the security module.

### **6.2.3 Channel 172 Usage**

One major work item was undertaken within this subtask during the year: testing the potential interference effect that a transmission in one channel has on communication in another channel, i.e. Cross-Channel Interference (CCI).

Three groups within the VSC-A team performed CCI tests, with the results of all three tests being similar. All tests included a transmitter-receiver pair on a target channel and an interfering transmitter on another channel. Variables included spectral distance between channels, geographic distance between the receiver and the two transmitters, the power of each transmitter, and the channel utilization of each transmitter.

Tests showed that a transmitter on an adjacent channel can cause interference when it is within a moderate distance of the receiver. Interference from a transmitter on non-adjacent channels was less conspicuous. The results were shared with the IEEE 802.11 TGp standards group. Refer to 0 for a link to the results.

Going forward, ways to mitigate any CCI effects and other potential multi-channel issues will be investigated (e.g. channel switching and effective strategies for safety message communication in a multi-channel environment).

### **6.2.4 Standards Validation**

The VSC-A team was very active in standards validation work this year with the Task 5.2 activities working in conjunction with Task 2 activities. The team is concerned with three standards groups: IEEE 802.11 Task Group p (TGp), IEEE 1609, and SAE DSRC.

#### **IEEE 802.11 TGp**

Task Group p is preparing the WAVE amendment to the 802.11 wireless networking standard, which will become 802.11p when published. This standard defines protocols at the Physical (PHY) and Medium Access Control (MAC) layers of the protocol stack.

The VSC-A team undertook both PHY and MAC layer validation work. The team's examination of the PHY layer compared the emerging 10 MHz Orthogonal Frequency-Division Multiplexing (OFDM) protocol with the requirements imposed by the physical channels over which VSC-A safety applications must operate. To that end, two groups within the VSC-A team performed detailed channel measurements in realistic highway, urban, and rural environments. The results of this channel modeling research were shared with the entire team.

Another aspect of PHY layer validation that was investigated is the interaction between channels within the 75 MHz DSRC band. The CCI results noted above were presented to TGp, for information purposes. The VSC-A team concluded that the best remedies for the interference effects observed are outside the scope of TGp, but also noted that strict adherence to the specified transmit channel masks would help mitigate CCI, as would aggressive receive channel rejection performance (e.g. as specified by the optional channel rejection objectives in the draft 802.11p standard).

The work in validating the MAC sub-layer protocol consisted mostly of evaluating the draft text for functionality, correctness, consistency, and clarity. To this end a detailed review of the D3.0 draft that was submitted for letter ballot with suggested improvements offered to TGp. TGp subsequently accepted text written by the VSC-A team to provide

core definitions and basic scope for WAVE operation. TGp consideration of other suggestions continues.

### **IEEE 1609.x**

The IEEE 1609.x series of standards define protocol layers between the MAC and the Application layers. 1609.1 through 1609.4 are designated “trial use” standards. The principal 1609.x validation activity focused on 1609.2, which defines Security protocols. The team’s evaluation was that the trial use version of 1609.2 carries a relatively high amount of bit overhead, which potentially has a negative effect on bandwidth efficiency. As noted previously, improved security mechanisms are being worked on that are planned to be, among other things, more bandwidth efficient.

### **SAE DSRC Technical Committee**

The SAE DSRC TC is responsible for the J2735 Message Set Dictionary standard. The emerging standard was analyzed and input was provided in two key areas. First, the importance of backward compatibility across future revisions of the standard was noted, and a request was made that the length of each data element be included in the message so that a message parser can skip an unknown element and continue parsing unhindered. To that end, a variety of solutions that meet this requirement were provided.

Second, the VSC-A team advised against a proposal to replace the single version of the Basic Safety Message (BSM) format with two versions, long and short, which would be interleaved. The team judged that the single-version proposal had significantly lower implementation and operational complexity.

The DSRC TC agreed on both of these issues. Work has also begun with the DSRC TC on the content of the fixed part (part I) of the BSM.

### **6.2.5 International Trends**

As stated in the VSC-A Technical Proposal, coordination with relevant international activities in the area of DSRC and vehicle safety applications are considered an important step in achieving a harmonized DSRC environment that would facilitate eventual worldwide deployment of DSRC-based vehicle safety applications. The activities under this subtask cover research information sharing between similar programs in the US, Europe, and Japan related to development of DSRC standards, vehicle safety communication, and deployment trends in each region. These international directions and trends will be analyzed to determine how they may relate to the VSC-A project activities.

In November of 2007, an international workshop for automotive data security was held at the Escar workshop in Munich, Germany. The VSC-A team took advantage of this workshop as an opportunity to engage the international vehicular communications community for the purpose of exchanging ideas on security issues. As part of the VSC-A team’s participation, the VSC-A security project was presented at the workshop

## **6.3 Relative Vehicle Positioning Development**

Subtask 5.3 is focused on developing a relative positioning system to be used for lane-level positioning that uses the Global Positioning System (GPS) as the core positioning technology and uses DSRC for exchanging necessary data between vehicles.

The VSC-A team investigated existing GPS-based systems used for high accuracy relative positioning applications. In addition to the CICAS-V lane-level positioning system implementation, the VSC-A team drew in expert input on existing technologies through a positioning technology workshop conducted at CAMP in March of 2007 to take into consideration in defining the positioning methodologies to be evaluated for the VSC-A Relative Positioning Module. Based on this input, three relative positioning methods were identified for further evaluation.

The three relative position methods, as well as development work outlined in the VSC-A project proposal, were formed into an RFQ sent out for competitive bidding. In addition to responding on the three methods included in the RFQ, the suppliers were given the freedom to evaluate new methodologies or variants of the three methods as part of their proposal. From the responses received, the VSC-A team selected two to further pursue from this process. The first solution is a basic Relative Positioning Module implementation based on off-the-shelf production hardware and customized software (SW). The second solution is based on customized non-production hardware and SW. Figure 4 shows a candidate configuration for the Relative Positioning Module and the GPS Receiver and their interactions with the rest of the VSC-A OBE setup.

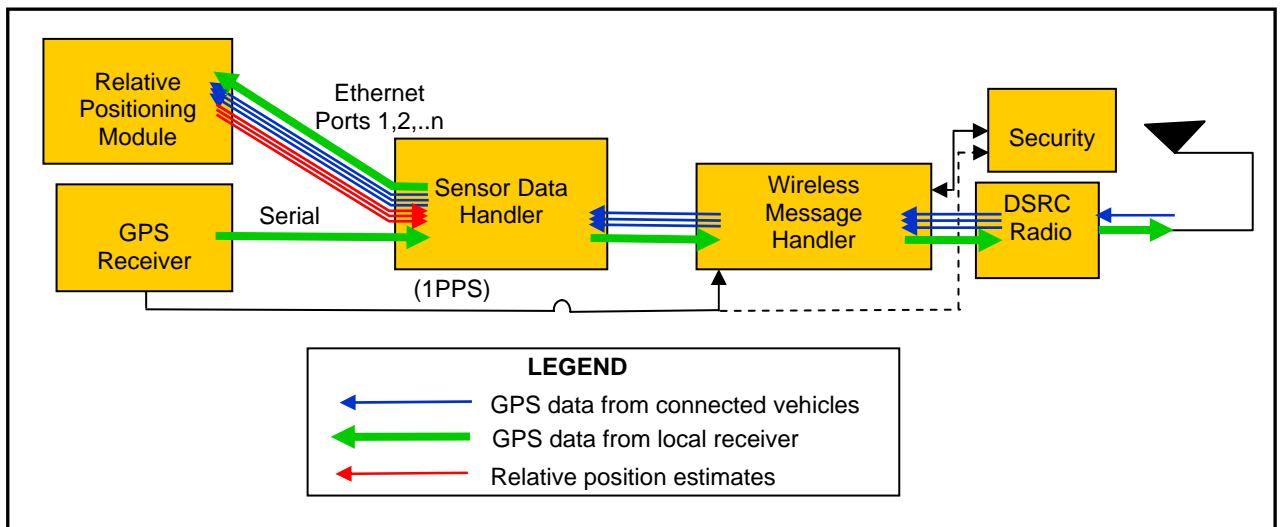

**Figure 4 – Candidate Relative Positioning Module Implementation**

With the positioning solutions to be pursued identified, the interface definition of the OBE to the relative positioning system was defined and provided as an input into the Task 7 Test Bed activities. It was defined such that both relative positioning implementations are interchangeable systems in the VSC-A test bed. In addition, both relative positioning system implementations will be using the same Over-The-Air (OTA) messaging format. The VSC-A team made considerable progress in identifying the messaging format through interactions with suppliers and working with the various standard bodies and have completed the design of the preliminary OTA data sharing scheme based on the SAE standards.

## **6.4 Integration of Forward-Looking Camera for Vehicle Positioning Aiding**

The purpose of Task 5.4 is to analyze the benefits and feasibility of exchanging vision-based sensor information among vehicles over the DSRC link to improve the overall performance of the VSC-A applications.

In order to potentially improve the GPS-based relative positioning performance, the VSC-A team investigated the technical benefit and feasibility of incorporating a forward-looking camera that is commonly used in lane tracking applications by automakers. Systems of this type are already available in production vehicles, and as such, may be considered feasible additions to improve positioning performance in future V2V systems.

The VSC-A team conducted a survey of currently available off-the-shelf automotive vision systems survey in June 2007 by contacting a number of the major system vendors and inquired about the availability and capabilities of each vendor's vision system. Subsequently, the vendor selection was completed based upon an analysis of these system capabilities.

After the vendor selection process, a unit from the selected vendor was purchased and installed in one of the VSC-A vehicles.

An initial performance evaluation of the vision system was conducted at the end of October 2007 and the resulting data was analyzed. The results indicated that the selected vision system had an acceptable level of accuracy for lane offset measurements and ranging distance measurements during good driving conditions with clear lane markers and without shadow edge conditions.

A preliminary paper analysis was completed to evaluate the potential benefits of integration of a forward-looking camera to aid GPS positioning. This analysis emphasized the potential benefits of determining the lateral offset between the vehicles with GPS breadcrumb data. The analysis also addressed the potential for enhancement of vehicle GPS systems with a forward-looking camera to:

- confirm the entering and exiting points of a curved road
- assist in the early detection of lane excursion
- assist in coasting during temporary GPS outages, while maintaining surrounding vehicles' relative position classification.

In the report, the potential benefits of enhanced capability in the future were also addressed.

## **7 Task 7 Summary: Vehicle Safety Communication System Test Bed**

Each VSC2 Consortium member is developing a vehicle test bed that will serve as a prototype platform for the VSC-A system. The test bed will serve to validate system specifications and performance tests that are being developed as part of this project. These vehicles will be upgraded to include a common On-Board Equipment (OBE) unit

with a customized relative positioning solution to achieve the required relative vehicle position performance. The OBE unit, which includes the DSRC radio, will be procured based on equipment currently developed for the CICAS-V and VII projects.

Three primary activities are planned for this task for the VSC-A System Test Bed, each of which are discussed in this section. These activities are:

- Test Bed Design
- Test Bed Development
- Test Bed In-vehicle Integration

## **7.1 VSC-A System Test Bed – Design**

The VSC-A Team kicked-off the Task 7 VSC-A system test bed design during the 3rd Quarter of 2007. The design relied on the requirements developed under Task 5.1 and were generated by the same sub-teams within the VSC-A team that worked on the requirements. Individual designs were developed for each of the following modules and were based on a common template that included the incorporation of the requirements, developed under Task 5.1, and design in a single document.

### Safety Application Modules

- Emergency Electronic Brake Light (EEBL)
- Forward Collision Warning (FCW)
- Intersection Movement Assist (IMA)
- Blind Spot Warning + Lane Change Warning (BSW + LCW)
- Do Not Pass Warning (DNPW)
- Control Loss Warning (CLW)

### System Framework Modules

- Path History (PH)
- Host Vehicle Path Prediction (HVPP)
- Target Classification (TC)
- Wireless Message Handler (WMH)
- Threat Arbitration (TA)

In addition to the modules listed above, detailed interface documentation was developed to document the data content and format of the:

- CAN data from the Netway (vehicle) device
- Over-the-Air DSRC messages
- Application and System Framework Modules

The Level I design for each of the safety application and system framework modules listed above, with the exception of TC were finalized by the end of 2007.

For TC a workshop was held to discuss the HVPP and PH designs, the results of which would impact TC. This included a presentation of the prototyping results of the multiple PH history methods under consideration. Of these, two PH methods were selected for test bed implementation. The workshop wrapped up with a discussion of TC requirement modifications required as a result of the decisions made during the HVPP and PH design reviews and the impact these modifications would have on the TC design efforts. Following this workshop, the design work for TC began and will be completed early in 2008.

## **7.2 VSC-A System Test Bed – Development**

A Request for Quotation (RFQ) was generated for a proposal and cost quotation to develop, implement, and verify a VSC-A On-Board Equipment (OBE) software implementation. This RFQ consists of eleven work packages (WP) divided into two levels of development referred to as Level I, consisting of WP1A – WP1E, and Level II, consisting of WP2A – WP2F.

A final statement of work (SOW) corresponding to the RFQ was received from the selected supplier and included the plan for the specification, development and verification of the software implementation as described in the RFQ. All work packages, with the exception of WP2B per mutual agreement, were included in the SOW. The final revision of the SOW was submitted and approved by the USDOT.

Following approval of the SOW, a kick-off meeting was held with the supplier to discuss:

- VSC-A test bed system block diagram overview, discussion, and Q&A
- Discussion of the HW interfaces and their management
- Underlying SW requirements architecture to take into account for future VSC-A implementation needs
- Discussion of the Security implementation and the coordination between the OBE and security suppliers
- Discussion of the Data Visualization and Logger test tool and the coordination between the OBE and test tool suppliers
- Preliminary major milestone and delivery dates

A final project schedule was received within the thirty day RFQ requirement and included the timeline and milestones for documentation delivery and reviews, SW scope and delivery, along with necessary workshops and face-to-face meetings.

The updated requirements developed under Task 5.1, corresponding design documentation developed under the Task 7 design activities, and interface definition specifications were provided to allow development to begin on the SW specification due in January of 2008.

A detailed VSC-A preliminary OBE software architecture diagram, as seen in Figure 5, was developed and revised as part of Task 4 activities. This architecture details the interaction between the safety application modules, system framework modules, OBE

Software Services, and external interface devices. For the corresponding preliminary HW interface diagram refer to Figure 7 – VSC-A Preliminary WSU HW Interfaces.

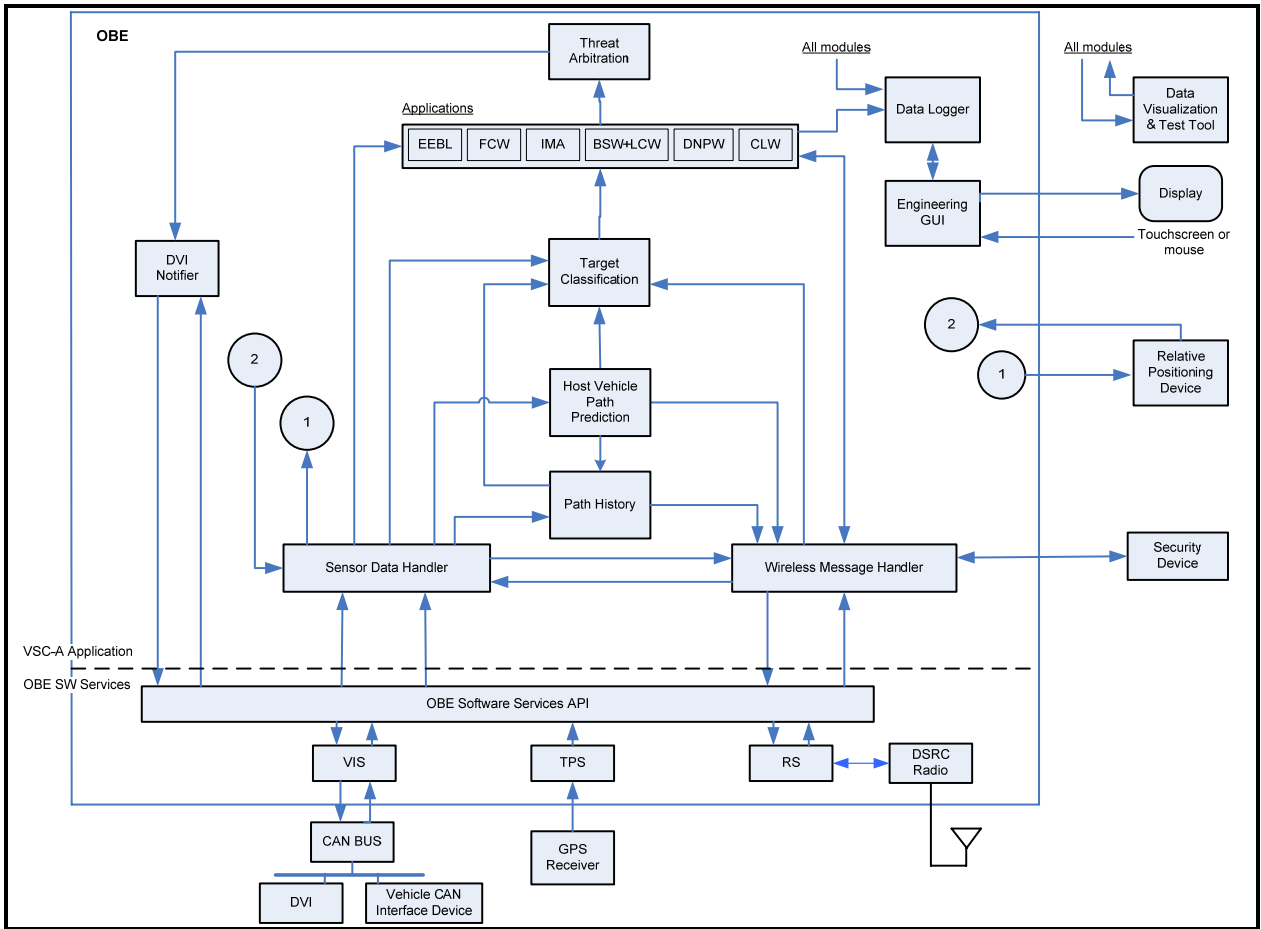

Figure 5 - VSC-A Preliminary OBE Software Architecture

### 7.3 VSC-A System Test Bed – In-Vehicle System Integration

This portion of VSC-A System Test Bed involves the identification, acquisition, installation, and integration of all the SW and HW required to complete the vehicle test bed and allow testing to proceed under subsequent tasks. Note that some aspects of the HW and SW identification are being handled through the activities of other tasks/sub-tasks.

#### Vehicle Selection

During 2007 each of the OEMs identified and acquired their test vehicle to use under the VSC-A program. In order to leverage the earlier vehicle build efforts that took place under the CICAS-V program, the same vehicles that were selected for CICAS-V were also selected for VSC-A. These vehicles are:

Ford	2007 Volvo S80
GM	2005 Cadillac STS Sedan
Honda	2006 Acura RL
Mercedes-Benz	2006 ML 350
Toyota	2006 Prius

**On-Board Equipment**

The On-Board Equipment (OBE) HW platform selected for the VSC-A program is the Wireless Safety Unit (WSU) developed by DENSO International America, Inc. LA Laboratories. The WSU solution is a custom computing and communications platform specifically designed for the development, implementation, testing and evaluation of vehicular safety applications. The device incorporates the Freescale 5200B PowerPC CPU to facilitate the development of automotive related applications and the software configuration uses Linux as the general purpose operating system (OS).

The WSU device incorporates a single board custom computing platform with standard automotive, embedded PC, and specialized communications interfaces. These interfaces are detailed in Figure 6 – WSU Single Radio Hardware and Interface Architecture.

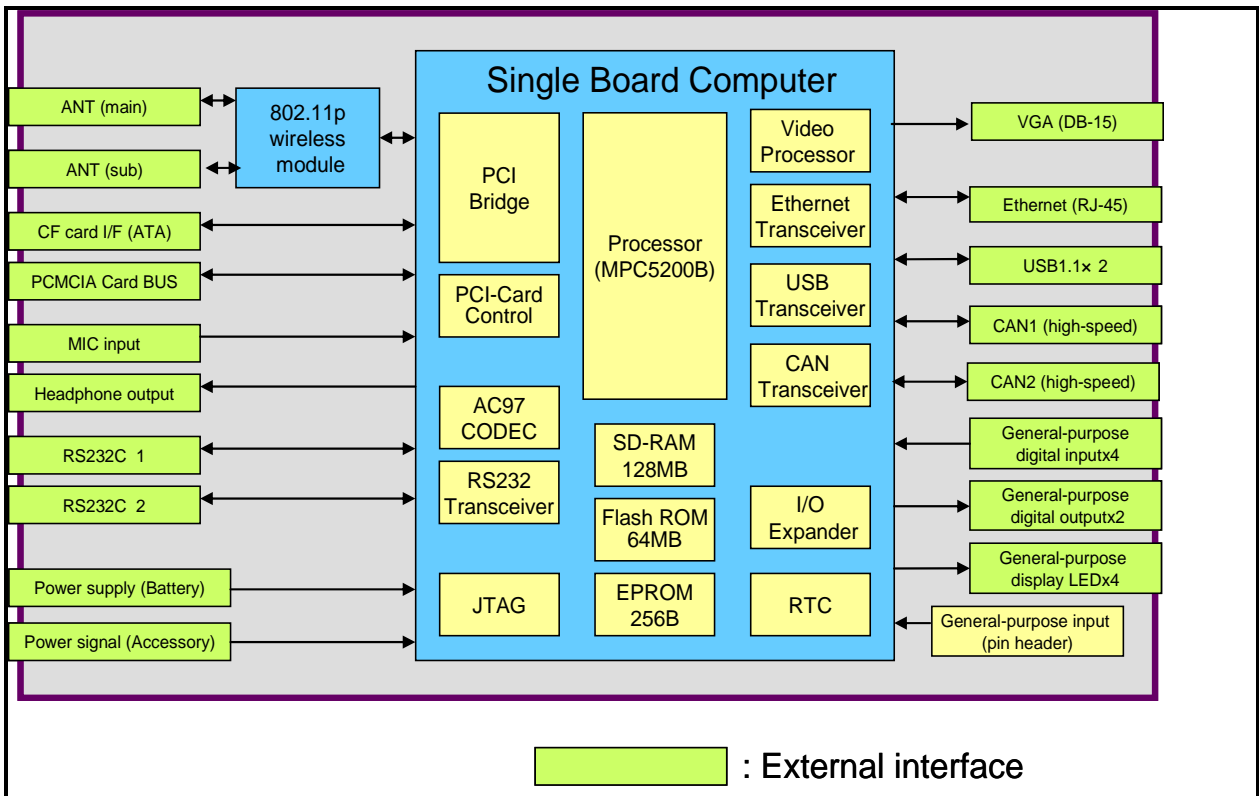

**Figure 6 – WSU Single Radio Hardware and Interface Architecture**

Some notable HW features and specifications are:

- Custom DSRC radio module with 19 + 1 dBm transmitter power out
- Mini-PCI port available for crypto/security accelerator or additional DSRC radio module
- Diversity antennas support
- Specific purpose RS-232 for GPS with 1 pulse/sec support
- Externally accessible PCMCIA type III slot
- Externally accessible Compact Flash slot (program memory)
- 64MB onboard flash
- 128MB onboard DDR-SDRAM
- 16 volt DC power input range
- Operating temperature range -30 to +70 deg C

The preliminary VSC-A Level I HW interface diagram is detailed in Figure 7. For the corresponding preliminary SW architecture diagram see Figure 5 - VSC-A Preliminary OBE Software Architecture.

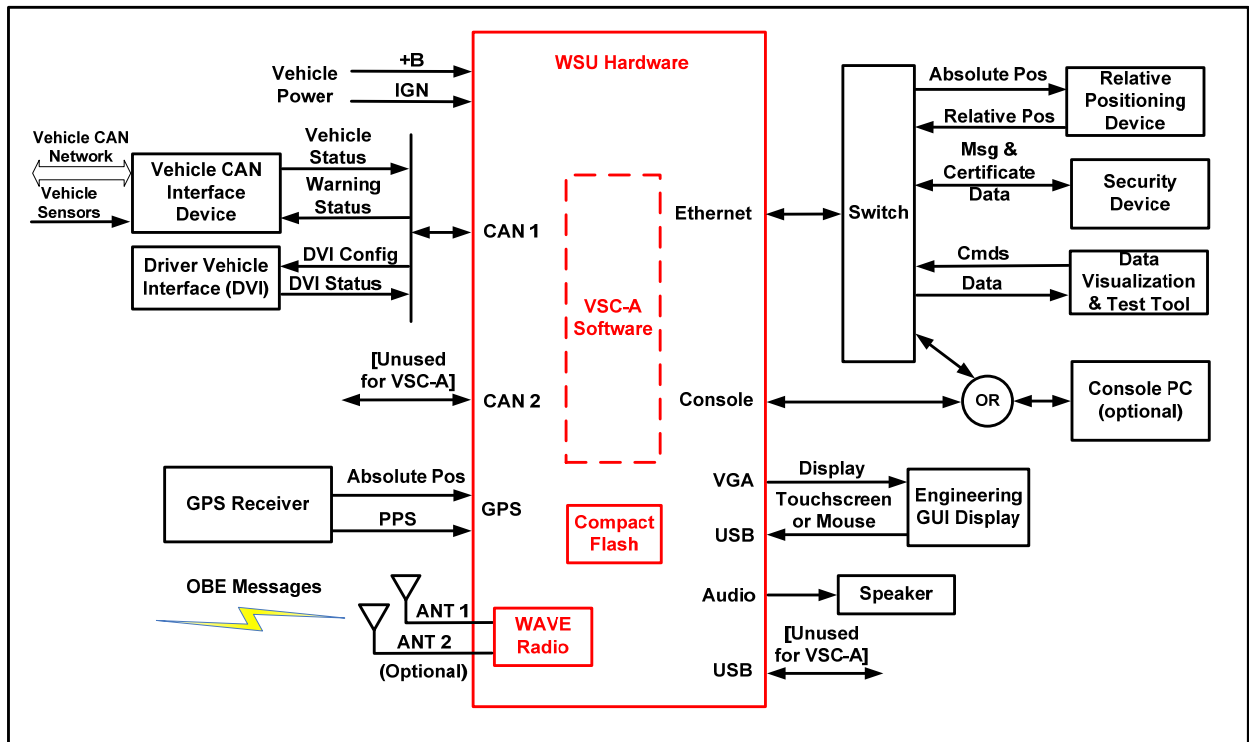

Figure 7 – VSC-A Preliminary WSU HW Interfaces

## **8 Task 10 Summary: Benefits Analysis Support**

As part of this task, the VSC-A team will provide the support as required by USDOT in the benefit analysis phase being planned with Volpe. During this quarter, a USDOT VSC-A safety benefits approach document, developed by Volpe, was provided to the VSC-A team for feedback and general comments. Highlights of this document were presented by Volpe to the VSC-A Team and NHTSA as part of the 4<sup>th</sup> VSC-A Briefing. Further development of this documentation is planned for early in 2008.

## **9 Task 11 Summary: Project Administration**

CAMP administered and coordinated the overall activities of the Cooperative Agreement and the VSC-A project and served as the single interface between all Participants and the Government in the performance of the Agreement. These activities included the following:

- Overall program management and coordination activities with NHTSA Program Office and Office of Acquisition Management
- Coordinated the submission of program milestones, deliverables and reporting requirements
- Coordinated activities related to Government requests for subsequent Work Order Proposals
- Ensured the coordination of CAMP project work order activities with other USDOT Programs and contractors in coordination with the NHTSA COTR
- Ensured proper communication and coordination amongst project work order Participants
- Conducted financial and administrative reviews of subcontract and sub-recipient proposals
- Issued and managed subcontracts and sub-awards
- Ensured the proper documentation, recording and tracking of project equipment
- Coordinated submission of invoices and cost reports
- Executed Agreement modifications and Project Order Amendments

## **10 Tasks 6, 8, and 9 Summary – No Major Activities**

No major activities to report under these tasks. Most of the work is scheduled for 2008.

## 11 References

- [1] Automotive Collision Avoidance System Field Operational Test, Final Program Report, DOT HS 809 886, May, 2005.
- [2] Bruce H. Wilson, Mary D. Stearns, Jonathan Koopman, C. Y. David Yang, Evaluation of a Road Departure Crash Warning System – Final Draft, January, 2007.
- [3] C.Y. David Yang, Bruce H. Wilson, Arthur Carter, Recommended Crash Imminent Test Scenarios for the Vehicle Safety Communications–Applications (VSC-A) Project, Internal NHTSA Project Memorandum, February, 2007.
- [4] Vinuth Rai, Fan Bai, John Kenney, Ken Laberteaux, Cross-Channel Interference Results: A report from the VSC-A project, July 17, 2007, <https://mentor.ieee.org/802.11/file/07/11-07-2133-00-000p-cross-channel-interference-test-results-a-report-from-the-vsc-a-project.ppt>.

## **12 Acronyms**

1PPS: One Pulse per Second

ACAS: Automotive Collision Avoidance System

BSSID: Basic Service Set Identifier

BSM: Basic Safety Message

BSW: Blind Spot Warning

CAMP: Crash Avoidance Metrics Partnership

CAN: Controller Area Network

CCI: Cross Channel Interference

CICAS-V: Cooperative Intersection Collision Avoidance System - Violation

CLW: Control Loss Warning

COTR: Contracting Officer Technical Representative

DNPW: Do Not Pass Warning

DSRC: Dedicated Short Range Communications

DVI: Driver-Vehicle Interface

EEBL: Emergency Electronic Brake Lights

FCW: Forward Collision Warning

FOT: Field Operational Test

GES: General Estimated System

GPS: Global Positioning System

GUI: Graphical User Interface

HVPP: Host Vehicle Path Prediction

HW/SW: Hardware/Software

I/O: Input/Output

IEEE: Institute of Electrical and Electronics Engineers

IMA: Intersection Movement Assist

ITS: Intelligent Transportation Systems

LB: Letter Ballot

LCW: Lane Change Warning

LTAP/OD: Left Turn Across Path/Opposite Direction

MAC: Medium Access Control layer

INS: Inertial Navigation System

NHTSA: National Highway Traffic Safety Administration

OBE: On-Board Equipment

OEM: Original Equipment Manufacturers

OFDM: Orthogonal Frequency-Division Multiplexing

OS: Operating System

OTA: Over-the-Air

PCS & CM: Pre-Crash Sensing and Collision Mitigation

PH: Path History

PHY: Physical layer

PI: Principal Investigator

RDCW: Road Departure Crash Warning

RFQ: Request for Quotations

SAE: Society of Automotive Engineers

SDH: Sensor Data Handler

SDO: Standards Development Organizations

SOW: Statement of Work

TA: Threat Arbitration

TC: Technical Committee

TGp: Task Group 802.11p

TMT: Technical Management Team

USDOT: United States Department of Transportation

VII-C: Vehicle-Infrastructure Integration - Consortium

VSC2: Vehicle Safety Communications 2

VSC: Vehicle Safety Communications

VSC-A: Vehicle Safety Communications – Applications

V-V or V2V: Vehicle-to-Vehicle

WAVE: Wireless Access in Vehicular Environments

WMH: Wireless Message Handler

WG: Working Group

WP: Work Package

WSU: Wireless Safety Unit

V-V or V2V: Vehicle-to-Vehicle

WAVE: Wireless Access in Vehicular Environments

VSC-A

*First Annual Report  
December 7, 2006 through December 31, 2007*

WBSS: WAVE Basic Service Set

WiFi: Wireless Fidelity

WG: Working Group

WSIE: WAVE Service Information Element